



KONICA MINOLTA

The essentials of imaging

bizhub C252

User's Guide [Copy Operations]

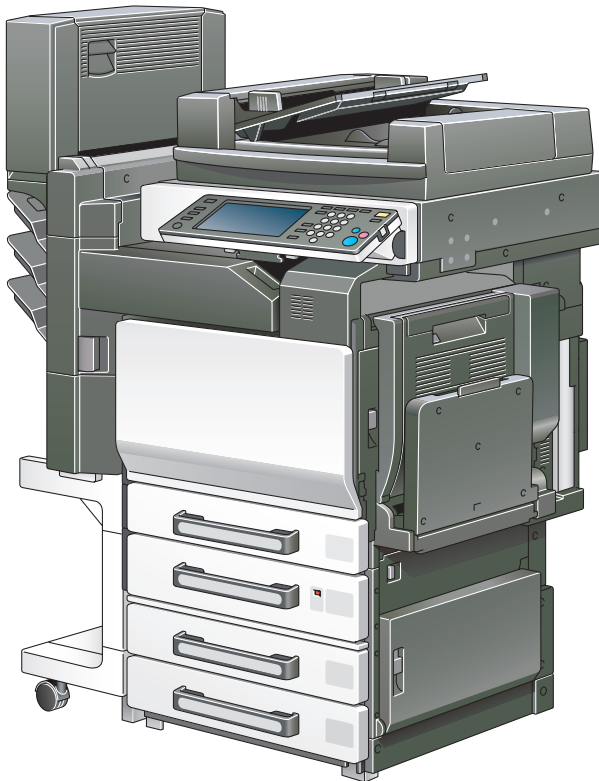

Introduction

Thank you for choosing this machine.

This manual contains details on the operation of the various functions of the machine, precautions on its use, and basic troubleshooting procedures. In order to ensure that this machine is used correctly and efficiently, carefully read this manual before using the machine. After reading the manual, store it in the designated holder so that it can easily be referred to when questions or problems arise during operation.

The illustrations used in this manual may appear slightly different from views of the actual equipment.

Energy Star®



As an ENERGY STAR® Partner, we have determined that this machine meets the ENERGY STAR® Guidelines for energy efficiency.

What is an ENERGY STAR® Product?

An ENERGY STAR® product has a special feature that allows it to automatically switch to a “low-power mode” after a period of inactivity. An ENERGY STAR® product uses energy more efficiently, saves you money on utility bills and helps protect the environment.

Trademarks and registered trademarks

KONICA MINOLTA, KONICA MINOLTA Logo, and The essentials of imaging are registered trademarks or trademarks of KONICA MINOLTA HOLDINGS, INC.

PageScope and bizhub are registered trademarks or trademarks of KONICA MINOLTA BUSINESS TECHNOLOGIES, INC.

Netscape Communications, the Netscape Communications logo, Netscape Navigator, Netscape Communicator, and Netscape are trademarks of Netscape Communications Corporation.

This machine and PageScope Box Operator are based in part on the work of the Independent JPEG Group.

Compact-VJE
Copyright 1986-2003 VACS Corp.

RC4[®] is a registered trademark or trademark of RSA Security Inc. in the United States and/or other countries.

RSA[®] is a registered trademark or trademark of RSA Security Inc. RSA BSAFE[®] is a registered trademark or trademark of RSA Security Inc. in the United States and/or other countries.



License information

This product includes RSA BSAFE Cryptographic software from RSA Security Inc.

OpenSSL Statement

OpenSSL License

Copyright © 1998-2000 The OpenSSL Project. All rights reserved. Redistribution and use in source and binary forms, with or without modification, are permitted provided that the following conditions are met:

1. Redistributions of source code must retain the above copyright notice, this list of conditions and the following disclaimer.
2. Redistributions in binary form must reproduce the above copyright notice, this list of conditions and the following disclaimer in the documentation and/or other materials provided with the distribution.
3. All advertising materials mentioning features or use of this software must display the following acknowledgment:
 “This product includes software developed by the OpenSSL Project for use in the OpenSSL Toolkit. (<http://www.openssl.org/>)”

4. The names “OpenSSL Toolkit” and “OpenSSL Project” must not be used to endorse or promote products derived from this software without prior written permission. For written permission, please contact openssl-core@openssl.org.
5. Products derived from this software may not be called “OpenSSL” nor may “OpenSSL” appear in their names without prior written permission of the OpenSSL Project.
6. Redistributions of any form whatsoever must retain the following acknowledgment:
“This product includes software developed by the OpenSSL Project for use in the OpenSSL Toolkit (<http://www.openssl.org/>)”

THIS SOFTWARE IS PROVIDED BY THE OpenSSL PROJECT “AS IS” AND ANY EXPRESSED OR IMPLIED WARRANTIES, INCLUDING, BUT NOT LIMITED TO, THE IMPLIED WARRANTIES OF MERCHANTABILITY AND FITNESS FOR A PARTICULAR PURPOSE ARE DISCLAIMED. IN NO EVENT SHALL THE OpenSSL PROJECT OR ITS CONTRIBUTORS BE LIABLE FOR ANY DIRECT, INDIRECT, INCIDENTAL, SPECIAL, EXEMPLARY, OR CONSEQUENTIAL DAMAGES (INCLUDING, BUT NOT LIMITED TO, PROCUREMENT OF SUBSTITUTE GOODS OR SERVICES; LOSS OF USE, DATA, OR PROFITS; OR BUSINESS INTERRUPTION) HOWEVER CAUSED AND ON ANY THEORY OF LIABILITY, WHETHER IN CONTRACT, STRICT LIABILITY, OR TORT (INCLUDING NEGLIGENCE OR OTHERWISE) ARISING IN ANY WAY OUT OF THE USE OF THIS SOFTWARE, EVEN IF ADVISED OF THE POSSIBILITY OF SUCH DAMAGE.

This product includes cryptographic software written by Eric Young (eay@crypt-Soft.com). This product includes software written by Tim Hudson (tjh@cryptsoft.com).

Original SSLeay License

Copyright © 1995-1998 Eric Young (eay@cryptsoft.com) All rights reserved. This package is an SSL implementation written by Eric Young (eay@cryptsoft.com).

The implementation was written so as to conform with Netscapes SSL. This library is free for commercial and non-commercial use as long as the following conditions are adhered to. The following conditions apply to all code found in this distribution, be it the RC4, RSA, lhash, DES, etc., code; not just the SSL code.

The SSL documentation included with this distribution is covered by the same copyright terms except that the holder is Tim Hudson (tjh@cryptsoft.com).

Copyright remains Eric Young’s, and as such any Copyright notices in the code are not to be removed. If this package is used in a product, Eric Young should be given attribution as the author of the parts of the library used. This can be in the form of a textual message at program startup or in documentation (online or textual) provided with the package.

Redistribution and use in source and binary forms, with or without modification, are permitted provided that the following conditions are met:

1. Redistributions of source code must retain the copyright notice, this list of conditions and the following disclaimer.
2. Redistributions in binary form must reproduce the above copyright notice, this list of conditions and the following disclaimer in the documentation and/or other materials provided with the distribution.
3. All advertising materials mentioning features or use of this software must display the following acknowledgement:
“This product includes cryptographic software written by Eric Young (eay@crypt-soft.com)”
The word ‘cryptographic’ can be left out if the routines from the library being used are not cryptographic related.
4. If you include any Windows specific code (or a derivative thereof) from the apps directory (application code) you must include an acknowledgement:
“This product includes software written by Tin Hudson (tjh@crypt-soft.com)”

THIS SOFTWARE IS PROVIDED BY ERIC YOUNG “AS IS” AND ANY EXPRESS OR IMPLIED WARRANTIES, INCLUDING, BUT NOT LIMITED TO, THE IMPLIED WARRANTIES OF MERCHANTABILITY AND FITNESS FOR A PARTICULAR PURPOSE ARE DISCLAIMED. IN NO EVENT SHALL THE AUTHOR OR CONTRIBUTORS BE LIABLE FOR ANY DIRECT, INDIRECT, INCIDENTAL, SPECIAL, EXEMPLARY, OR CONSEQUENTIAL DAMAGES (INCLUDING, BUT NOT LIMITED TO, PROCUREMENT OF SUBSTITUTE GOODS OR SERVICES; LOSS OF USE, DATA, OR PROFITS; OR BUSINESS INTERRUPTION) HOWEVER CAUSED AND ON ANY THEORY OF LIABILITY, WHETHER IN CONTRACT, STRICT LIABILITY, OR TORT (INCLUDING NEGLIGENCE OR OTHERWISE) ARISING IN ANY WAY OUT OF THE USE OF THIS SOFTWARE, EVEN IF ADVISED OF THE POSSIBILITY OF SUCH DAMAGE.

The licence and distribution terms for any publically available version or derivative of this code cannot be changed. i.e. this code cannot simply be copied and put under another distribution licence [including the GNU Public Licence.]

All other product names mentioned are trademarks or registered trademarks of their respective companies

Contents

Introduction

Energy Star®	x-1
What is an ENERGY STAR® Product?	x-1
Trademarks and registered trademarks	x-2
Contents	x-5
Available features	x-18
Selecting the print color	x-18
Automatically selecting the paper	x-18
Adjusting copies to the size of the paper	x-18
Specifying separate horizontal and vertical zoom ratios	x-18
Scanning the document in separate batches	x-18
Center binding	x-19
Sorting copies	x-19
Stapling copies	x-19
Punching holes in copies	x-19
Copying multiple document pages onto a single page	x-20
Copying a document containing various page sizes	x-20
Adjusting copies according to the image quality of the original ...	x-20
Inserting paper between copies of overhead projector transparencies	x-20
Adding a cover page	x-21
Inserting different paper into copies	x-21
Inserting pages from a different document at specified locations in a copy	x-21
Printing double-sided copies with the specified page on the front side	x-22
Copying with reversed colors	x-22
Printing a mirror image	x-22
Copying with a background color	x-23
Improving the copy color quality	x-23
Separately copying a page spread	x-23
Creating booklets from copies of pamphlets	x-23
Repeating copy images	x-24
Printing the enlarged image on multiple pages	x-24
Making copies for filing	x-24
Copying with the page layout of a magazine	x-25
Erasing sections of copies	x-25
Adjusting the image to fit the paper size	x-25
Printing distribution numbers or copy protection text on copies	x-26
Managing jobs	x-26
Programming copy settings	x-26

Checking the copy settings	x-26
Enlarging the size of text in touch panel screens	x-26
Displaying explanations of functions and settings	x-26
Interrupting a copy job	x-27
Printing a sample copy	x-27
Adjust color parameters	x-28
General information about color	x-30
Relationship between hue, brightness and saturation (color model)	x-31
“Red” parameter	x-32
“Green” parameter	x-33
“Blue” parameter	x-34
“Color Balance” parameter (CMYK color adjustment)	x-35
“Brightness” parameter	x-37
“Contrast” parameter	x-38
“Saturation” parameter	x-39
“Sharpness” parameter	x-40
“Hue” parameter	x-41
“Copy Density” parameter	x-42
“Single Color” function	x-43
“2 Color” function	x-44
“Background Color” function	x-45
“Neg-/Pos. Reverse” function	x-46
Monotone copy	x-46
Full-color copy and “Background Color” function	x-46
“Mirror Image” function	x-47
Explanation of manual conventions	x-48
Descriptions and symbols for documents and paper	x-50
“Width” and “Length”	x-50
Paper Orientation	x-50
User’s Guides	x-52
User’s Guide [Copy Operations] <this manual>	x-52
User’s Guide [Network Scanner Operations]	x-52
User’s Guide [Box Operations]	x-52
User’s Guide [Enlarge Display Operations]	x-52
User’s Guide [FK-502 Facsimile Operations]	x-52
User’s Guide [Network Facsimile Operations]	x-52
User’s Guide [Print Operations]	x-53

Quick Guide [Print Operations]x-53

Legal restrictions on copying x-54

1 Installation and operation precautions

1.1	Safety information	1-2
	Warning and precaution symbols	1-2
	Meaning of symbols	1-2
1.2	Regulation notices	1-9
	CE Marking (Declaration of Conformity) for users of the European Union (EU)	1-9
	USER INSTRUCTIONS FCC PART 15 - RADIO FREQUENCY DEVICES (for U.S.A. users)	1-9
	INTERFERENCE-CAUSING EQUIPMENT STANDARD (ICES-003 ISSUE 4) (for Canada users)	1-9
	For users in countries not subject to class B regulations	1-10
	Laser safety	1-10
	Internal laser radiation	1-10
	CDRH regulations	1-11
	For European users	1-12
	For Denmark users	1-12
	For Finland, Sweden users	1-12
	For Norway users	1-13
	Laser safety label	1-14
	Ozone release	1-14
	Acoustic noise (for European users only)	1-15
	For EU member states only	1-15
	For EU member states only	1-15
1.3	Caution notations and labels	1-16
1.4	Space requirements	1-17
1.5	Operation precautions	1-18
	Power source	1-18
	Operating environment	1-18
	Storage of copies	1-18

2 Before making copies

2.1	Part names and their functions	2-2
	Options	2-2
	Outside of machine	2-5
	Inside of machine	2-11
	Saddle stitcher SD-503/mailbin kit MT-501	2-13
	Finisher FS-514/output tray OT-601/punch kit PK-510	2-14
	Finisher FS-603/punch kit PK-501	2-16

	Finisher FS-501/job separator JS-601	2-18
	Control panel	2-21
	Basic settings screen (Basic screen)	2-24
	Icons that appear in the screen	2-26
2.2	Adjusting the angle of the control panel	2-27
	To adjust the angle of the control panel	2-27
2.3	Turning on the Main Power and the Auxiliary Power	2-29
	To turn on the machine	2-29
	To scan during warm-up	2-31
	To turn off the machine	2-33
	Automatically canceling the settings (automatic panel reset)	2-34
	Automatically canceling the mode screen (automatic system reset)	2-34
	Automatically conserving energy (Low Power mode)	2-35
	Automatically conserving energy (Sleep mode)	2-36
	Manually conserving energy	2-37
	Automatically turning the machine on/off (weekly timer)	2-38
	Controlling each user's use of this machine (user authentication)	2-40
	Controlling each account's use of this machine (account track)	2-43
2.4	Loading paper into the 1st tray	2-47
	To load paper (1st tray)	2-47
2.5	Loading paper into the 2nd, 3rd or 4th tray	2-53
	To load paper (2nd, 3rd or 4th tray)	2-53
2.6	Loading paper into the LCT	2-55
	To load paper (LCT)	2-55
2.7	Loading paper into the bypass tray	2-58
	To load paper (bypass tray)	2-58

3 Basic copy operations

3.1	General copy operation	3-2
	To make a copy	3-2
3.2	Operations that cannot be combined	3-5
	Operations where the setting specified last is given priority	3-5
	Operations where the setting specified first is given priority	3-6
3.3	Feeding the document	3-7
	To load the document into the ADF	3-7
	To place the document on the original glass	3-9
	Scanning the document in separate batches ("Separate Scan" setting)	3-11

	Scanning a multi-page document from the original glass	3-15
3.4	Specifying original settings	3-20
	Copying documents of mixed sizes (“Mixed Original” setting)	3-20
	Copying thick documents (“Thick Original” setting)	3-22
	Selecting the document orientation	
	(Original Direction settings)	3-24
	To specify an original direction setting	3-25
	Selecting the position of the binding margin (Margin settings)	3-26
	To specify a margin setting	3-27
	To change scan settings for each document	3-29
3.5	Selecting a color setting	3-32
	To select a color setting	3-33
3.6	Selecting a paper setting	3-35
	Automatically selecting the paper size	
	(“Auto Paper Select” setting)	3-35
	Manually selecting the desired paper size	3-37
3.7	Specifying a zoom setting	3-38
	Automatically selecting the zoom ratio (“Auto Zoom” setting)	3-38
	Specifying the same zoom ratio as the document	
	(“×1.0” setting)	3-39
	Slightly reducing the copy (“Minimal” setting)	3-40
	Selecting a preset zoom ratio (enlarge and reduce settings)	3-41
	Typing In the zoom ratio (XY Zoom setting)	3-42
	Typing In separate X and Y zoom ratios	
	(independent zoom settings)	3-44
	Selecting a stored zoom ratio	3-46
	Storing the desired zoom ratio	3-47
3.8	Selecting the document and copy type settings	
	(Simplex/Duplex settings)	3-49
	To select single-sided copies	3-51
	To select double-sided copies	3-53
3.9	Selecting the quality of the document	3-55
	Loading documents with small print or photos	
	(Original Type settings)	3-55
	To specify an original type setting	3-56
3.10	Specifying the density settings	3-59
	Adjusting the print density (Density settings)	3-60
	Adjusting the background density	
	(Background Removal settings)	3-61
	Adjusting the reproduction quality of text	3-63

3.11	Selecting a combine originals setting	3-64
	Copying multiple document pages onto a single page (Combine Originals)	3-66
3.12	Selecting finishing settings	3-67
	Separating copies by sets (“Sort” setting)	3-70
	Separating copies by pages (“Group” setting)	3-71
	Stapling copies (Staple settings)	3-72
	To bind copies with staples	3-75
	Punching holes in copies (Punch settings)	3-77
	To punch holes in copies	3-78
3.13	Specifying center binding	3-80
	To bind copies at the center (“Fold & Staple”): Finisher FS-514	3-82
	To bind copies at the center (“Fold & Staple”): Finisher FS-603	3-83
3.14	Scanning the next document to be copied while a copy job is being printed (next job reservation)	3-84
	To reserve a copy job	3-84
3.15	Stopping scanning/printing	3-86
	To stop scanning/printing	3-86
3.16	Deleting a stopped job	3-87
	To delete a stopped job	3-87

4 Additional copy operations

4.1	Checking the copy settings (Mode Check)	4-2
	To check the settings	4-2
	To change the settings	4-4
4.2	Printing a proof copy to be checked (Proof Copy)	4-5
	To make test prints	4-5
4.3	Interrupting a copy job (Interrupt mode)	4-8
	To interrupt a copy job	4-8
4.4	Registering copy programs (Mode Memory)	4-10
	To store a copy program	4-10
	To delete a copy program	4-13
4.5	Copying with programmed copy settings (Mode Memory)	4-14
	To recall a stored job	4-14
4.6	Displaying function descriptions (Help)	4-17
	Overview of Help Screens	4-17
	To display the Main Help Menu screen	4-20
	To display the Help screen while specifying a setting	4-22

4.7	Specifying control panel settings (Accessibility mode)	4-23
	Displaying the Accessibility Setting Screen	4-23
	To set the “Key Repeat Start/Interval Time” function	4-23
	To set the “Enlarge Display Timer Setting” function	4-26
	To set the “Message Display Time” function	4-28
	To set the “Sound Setting” function	4-30
	To set the “Touch Panel Adj.” function	4-33
	To set the “Auto Reset Notification” function	4-35
	To set the “Enlarge Display Confirmation Screen” function	4-38

5 Troubleshooting

5.1	When the message “malfunction detected.” appears (call technical representative)	5-2
	To call the technical representative	5-3
5.2	When the message “Misfeed detected.” appears	5-5
	Location of Paper misfeed	5-5
	Paper misfeed indications	5-7
	To clear a paper misfeed in the bypass tray	5-9
	To clear a paper misfeed in the automatic duplex unit	5-10
	To clear a paper misfeed in the 1st tray	5-11
	To clear a paper misfeed in the 2nd tray	5-12
	To clear a paper misfeed in a paper tray (3rd or 4th tray)	5-13
	To clear a paper misfeed in the LCT	5-14
	To clear a paper misfeed in the right-side door	5-16
	To clear a paper misfeed in the fusing unit	5-19
	To clear a banner paper misfeed	5-23
	To clear a paper misfeed in the ADF	5-28
	To clear a paper misfeed in the finisher FS-514	5-32
	To clear a paper misfeed in the mailbin	5-36
	To clear a paper misfeed in the saddle stitcher	5-38
	To clear a paper misfeed in finisher FS-501	5-40
	To clear a paper misfeed in finisher FS-603	5-45
5.3	When the message “Replenish paper.” appears	5-49
	To replenish paper	5-49
5.4	When the message “... Not enough remaining memory.” appears	5-50
	Memory becomes full while scanning	5-50
	Memory becomes full while queuing a job	5-51
5.5	When “Please replace following unit(s).” appears	5-52
5.6	When the message “Need to replace XXXX.” appears	5-53
5.7	Simple troubleshooting	5-55
	Main unit	5-55
	ADF	5-57

Finisher	5-58
5.8 Main messages and their remedies	5-59
6 Specifications	
6.1 Specifications	6-2
bizhub C252	6-2
Option specifications	6-5
Automatic duplex unit AD-503	6-5
Automatic document feeder DF-601	6-5
Paper feed cabinet PC-103	6-7
Paper feed cabinet PC-203	6-7
Paper feed cabinet PC-403	6-7
Finisher FS-514	6-8
Punch kit PK-510	6-9
Saddle stitcher SD-503	6-9
Output tray OT-601	6-9
Mailbin kit MT-501	6-10
Finisher FS-603	6-11
Punch kit PK-501	6-12
Finisher FS-501	6-12
Job separator JS-601	6-13
7 Copy paper/original documents	
7.1 Copy paper	7-2
Possible paper sizes	7-2
Paper types and paper capacities	7-4
Special paper	7-5
Precautions for paper	7-7
Paper storage	7-7
Auto tray switch feature	7-8
Order for Selecting the Paper trays	7-8
7.2 Selecting the paper settings	7-9
To automatically detect the paper size ("Auto Paper Select" setting)	7-9
To specify a paper size (set size settings)	7-11
To specify a non-standard paper size (Custom Size settings)	7-13
To store a non-standard paper size (Custom Size settings)	7-15
To specify a setting for oversized paper (Oversized Paper settings)	7-18
To specify a setting for special paper	7-21
To print double-sided copies manually	7-23
7.3 Original documents	7-25
Documents that can be loaded into the ADF	7-25

Precautions for loading documents into the ADF	7-27
Documents that can be placed on the original glass	7-28
Precautions for positioning documents on the original glass	7-28

8 Application functions

8.1 Inserting paper between overhead projector transparencies (“OHP Interleave” function)	8-2
To copy using the “OHP Interleave” function	8-3
8.2 Adding cover pages (“Cover Mode” function)	8-5
To copy using the “Cover Mode” function	8-6
8.3 Inserting different paper into copies (“Insert Sheet” function)	8-8
To copy using the “Insert Sheet” function	8-9
8.4 Inserting copies of a different document for a specified page (“Insert Image” function)	8-12
To copy using the “Insert Image” function	8-12
8.5 Specifying pages to be printed on the front side (“Chapters” function)	8-16
To copy using the “Chapters” function	8-17
8.6 Scanning documents with different settings and printing copies all together (“Program Job” function)	8-19
To copy using the “Program Job” function	8-20
8.7 Producing separate copies of each page in a page spread (“Book Copy” function)	8-24
To copy using the “Book Copy” function	8-25
8.8 Copying pamphlets (“Booklet Original” function)	8-29
To copy using the “Booklet Original” function	8-30
8.9 Tiling copy images (“Image Repeat” function)	8-33
To copy using the “Image Repeat” function	8-34
8.10 Copying an enlarged image on multiple pages (“Poster Mode” function)	8-38
To copy using the “Poster Mode” function	8-38
8.11 Copying with the page layout of a magazine (“Booklet” function)	8-43
To copy using the “Booklet” function	8-44
8.12 Copying with image colors inversed (“Neg-/Pos. Reverse” function)	8-45
To copy using the “Neg-/Pos. Reverse” function	8-46
8.13 Copying in a mirror image (“Mirror Image” function)	8-47
To copy using the “Mirror Image” function	8-47

8.14	Adding a background color to copies (“Background Color” function)	8-51
	To copy using the “Background Color” function	8-51
8.15	Adjusting the copy color quality (Adjust Color parameters)	8-53
	To adjust the Adjust Color parameters	8-54
	Checking the Print Result of the Adjust Color Settings (Sample Copy)	8-56
	To make sample copies	8-57
8.16	Adding filing margins to copies (“Page Margin” function)	8-58
	To copy using the “Page Margin” function	8-59
8.17	Erasing specified areas of copies (“Erase” function)	8-61
	To copy using the “Erase” function	8-61
8.18	Adjusting the image to fit the paper (Image Adjustment settings)	8-63
	To copy using the Image Adjustment settings	8-64
8.19	Printing the Date/Time, page number or distribution number on copies (Stamp functions)	8-67
	Printing the Date/Time (“Date/Time” function)	8-68
	To copy using the “Date/Time” function	8-68
	Printing the page number (“Page #” function)	8-71
	To copy using the “Page #” function	8-71
	Printing the distribution number (“Set Numbering” function)	8-75
	To copy using the “Set Numbering” function	8-75
	Printing copy protection text (“Copy Protect” function)	8-77
	To copy using the “Copy Protect” function	8-77

9 Replacing toner cartridges and staples and emptying waste containers

9.1	Replacing the toner cartridge	9-2
	To replace the toner cartridge	9-6
9.2	Replacing the staples	9-10
	To replace the staple cartridge in the finisher FS-514	9-11
	To replace the staple cartridge in saddle stitcher	9-13
	To replace the staple cartridge for finisher FS-501	9-16
	To replace the staple cartridge for finisher FS-603	9-19
9.3	Clearing a staple jam	9-24
	To clear jammed staples in the finisher FS-514	9-26
	To clear jammed staples in the saddle stitcher	9-31
	To clear jammed staples in finisher FS-501	9-35
	To clear jammed staples in finisher FS-603	9-37

9.4	Emptying the waste containers	9-43
	To empty the hole-punch waste container for finisher FS-514	9-45
	To empty the hole-punch waste container for finisher FS-603	9-46
9.5	Replacing the waste toner box	9-48
	To replace the waste toner box	9-50

10 Care of the machine

10.1	Cleaning	10-2
	Housing	10-2
	Original glass	10-3
	Control panel	10-3
	Document transfer belt	10-4
	Original cover pad	10-5
	Paper Take-Up roller	10-5
	Electrostatic charger wire	10-6
	Print head	10-7
10.2	Viewing counters (Meter Count)	10-8
	Viewing counters	10-8
	To view the counters	10-8
	Viewing the coverage rate	10-9
	To view the coverage rate	10-9
10.3	When the message “Preventive maintenance time.” appears	10-10

11 Managing jobs (Job List)

11.1	Overview of the Job List screen	11-2
	Jobs	11-2
	Multi-Job feature	11-2
	Job list screens	11-3
11.2	Performing operations on jobs	11-6
	To delete a job	11-6
	To check the job settings	11-8
	Displayed information	11-9
	To check the job details	11-10
	To display current jobs (held jobs and active jobs lists)	11-11
	To display Job History	11-12
	To print a sample copy of a stored job	11-13
	To print a stored job	11-15
	To increase priority for printing	11-17

12 Utility

12.1	Overview of utility mode parameters	12-2
	List of registration information and parameters	12-2
12.2	Selecting a destination register	12-14
	Scan	12-14
	Fax	12-14
	User box	12-14
	Displaying the destination register screen	12-15
12.3	Specifying user settings	12-17
	System setting	12-17
	Display setting	12-19
	Initial setting	12-21
	Copier setting	12-22
	Scanner setting	12-24
	Printer setting	12-24
	Displaying the Utility Setting screen	12-25
12.4	Specifying administrator settings	12-27
	System setting	12-27
	Administrator/machine setting	12-37
	One-Touch registration	12-37
	User authentication/account track	12-38
	Network setting	12-40
	Copier setting	12-40
	Printer setting	12-41
	Fax setting	12-41
	System connection	12-42
	Security setting	12-43
	Displaying the Administrator Setting screen	12-47
12.5	Overview of weekly timer settings	12-49
	Requisite	12-49
12.6	Adjusting the printer	12-50
	Adjusting the starting print position at the leading edge position	12-50
	Adjusting the starting print position at the left edge	12-52
	Adjusting the starting print position for the second side	12-54
	Adjusting printing according to the media	12-56
12.7	Adjusting the finisher (FS-514)	12-58
	Adjusting the center folding position	12-58
	Adjusting the center stapling position	12-60
	Adjusting the horizontal punch position	12-62
	Adjusting the angle of punched holes	12-64

12.8	Adjusting the finisher (FS-603)	12-66
	Adjusting the center stapling position	12-66
	Adjusting the center folding position	12-69
12.9	Adjusting the color registration	12-72
	Adjusting the color registration for yellow, magenta and cyan	12-72
12.10	Adjusting the gradation levels	12-75
	Requisite	12-75
12.11	Authentication method	12-78
	User authentication and account track	12-78
	When user authentication and account track are synchronized	12-79
	When user authentication and account track are used separately	12-80
	To select an authentication method	12-81
12.12	User authentication setting	12-86
	Administrative setting—user name list	12-86
	Default function permission	12-87
	To specify the default function permissions	12-87
	Authenticating public users	12-88
	User registration	12-90
	User counter	12-95
	To check the counter	12-96
12.13	Account track setting	12-98
	Account track registration	12-98
	Account track counter	12-102
	To check the counter	12-103
12.14	Password rules	12-105
	Conditions of the password rules	12-105
12.15	Enhanced security settings	12-107
12.16	Viewing the status of the consumables	12-110
	Displaying the unit life indicator screen	12-110

13 Appendix

13.1	Entering text	13-2
	To type text	13-4
	List of available characters	13-4
13.2	Glossary	13-5
13.3	Index	13-10

Available features

Selecting the print color

The color used to print copies can be specified, for example, the copy can be printed in full color or in black and white.

For details, refer to “Selecting a color setting” on page 3-32.

Automatically selecting the paper

The most appropriate paper size can automatically be selected based on the size of the loaded document and the specified zoom ratio.

For details, refer to “Automatically selecting the paper size (“Auto Paper Select” setting)” on page 3-35.

Adjusting copies to the size of the paper

The most appropriate zoom ratio can automatically be selected based on the size of the loaded document and the specified paper size.

For details, refer to “Automatically selecting the zoom ratio (“Auto Zoom” setting)” on page 3-38.

Specifying separate horizontal and vertical zoom ratios

By specifying separate horizontal and vertical zoom ratios, copies of the document can be resized as desired.

For details, refer to “Typing In separate X and Y zoom ratios (independent zoom settings)” on page 3-44.

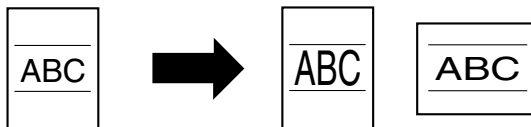

Scanning the document in separate batches

A document with a large number of pages can be divided and scanned in separate batches. Double-sided copies can be produced by using the original glass or the document pages can be alternately loaded onto the original glass or into the ADF, and then all pages can be copied together as a single job.

For details, refer to “Scanning the document in separate batches (“Separate Scan” setting)” on page 3-11 and “Scanning a multi-page document from the original glass” on page 3-15.

Center binding

Copies can be folded at their center and bound with staples.

For details, refer to “To bind copies at the center (“Fold & Staple”): Finisher FS-603” on page 3-83.

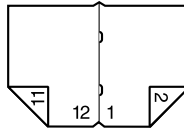

Sorting copies

The finishing method for copies can be selected.

For details, refer to “Separating copies by sets (“Sort” setting)” on page 3-70, “Separating copies by pages (“Group” setting)” on page 3-71.

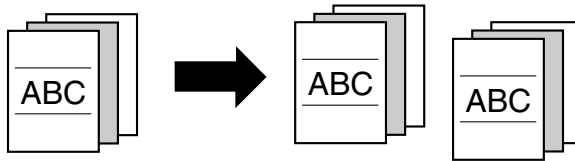

Stapling copies

Multi-page documents can be copied and stapled together.

For details, refer to “Stapling copies (Staple settings)” on page 3-72.

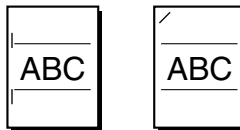

Punching holes in copies

Holes for filing can be punched in the copies.

For details, refer to “Punching holes in copies (Punch settings)” on page 3-77.

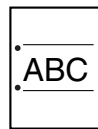

Copying multiple document pages onto a single page

Multiple pages of the document can be printed together on a single page.

For details, refer to “Copying multiple document pages onto a single page (Combine Originals)” on page 3-66.

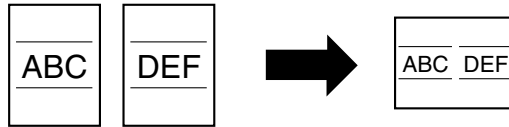

Copying a document containing various page sizes

A document with various page sizes can be scanned and copied together.

For details, refer to “Copying documents of mixed sizes (“Mixed Original” setting)” on page 3-20.

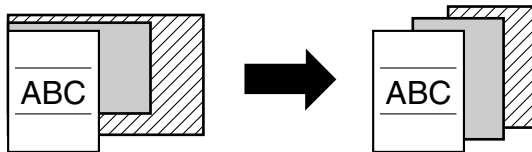

Adjusting copies according to the image quality of the original

The copies can be adjusted according to the image quality of the document.

For details, refer to “Loading documents with small print or photos (Original Type settings)” on page 3-55 or “Adjusting the print density (Density settings)” on page 3-60.

Inserting paper between copies of overhead projector transparencies

In order to prevent overhead projector transparencies from becoming stuck to each other, a page (interleaf) can be inserted between the transparency copies.

For details, refer to “Inserting paper between overhead projector transparencies (“OHP Interleave” function)” on page 8-2.

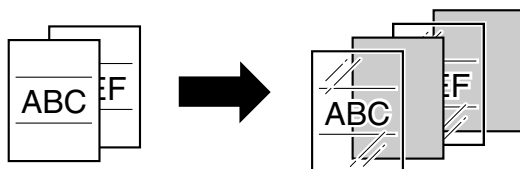

Adding a cover page

Cover pages can be added to copies, or copies can be made using different paper (for example, colored paper) for only the cover pages.

For details, refer to “Adding cover pages (“Cover Mode” function)” on page 8-5.

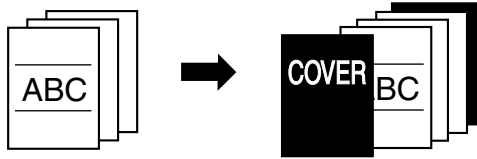

Inserting different paper into copies

Different paper (such as colored paper) can be inserted for specified pages in the copies.

For details, refer to “Inserting different paper into copies (“Insert Sheet” function)” on page 8-8.

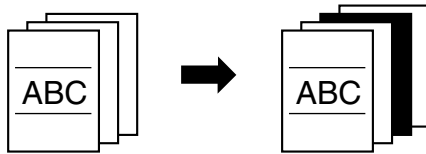

Inserting pages from a different document at specified locations in a copy

A document scanned later can be inserted for specified pages in a document scanned earlier for copying.

For details, refer to “Inserting copies of a different document for a specified page (“Insert Image” function)” on page 8-12.

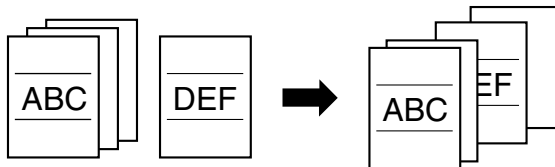

Printing double-sided copies with the specified page on the front side

Double-sided copies can be printed with the specified pages on the front side.

For details, refer to “Specifying pages to be printed on the front side (“Chapters” function)” on page 8-16.

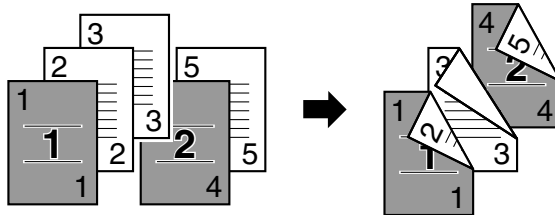

Copying with reversed colors

A document can be copied with the light- and dark-colored areas of the document image inverted. With Color setting “Full Color”, copies are printed with the hues and brightness inverted. With Color setting “Black” or “Single Color”, copies are printed with the hues inverted.

For details, refer to “Copying with image colors inverted (“Neg-/Pos. Reverse” function)” on page 8-45.

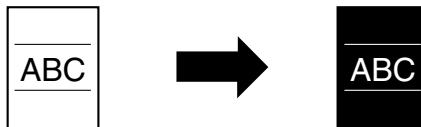

Printing a mirror image

A document can be copied in its mirror image.

For details, refer to “Copying in a mirror image (“Mirror Image” function)” on page 8-47.

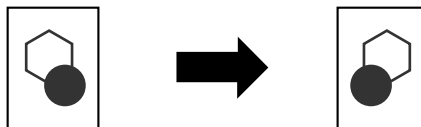

Copying with a background color

A document can be copied using one of the 18 colors available as the color of the background (blank areas).

For details, refer to “Adding a background color to copies (“Background Color” function)” on page 8-51.

Improving the copy color quality

You can adjust color copies to the quality for the desired image.

For details, refer to “Adjusting the copy color quality (Adjust Color parameters)” on page 8-53.

Separately copying a page spread

A page spread, such as in an open book or catalog, can be copied onto separate pages.

For details, refer to “Producing separate copies of each page in a page spread (“Book Copy” function)” on page 8-24.

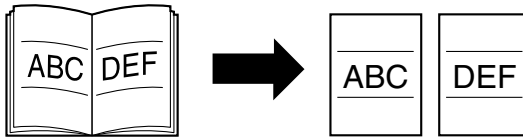

Creating booklets from copies of pamphlets

Pamphlets with their staples removed can be copied and bound with staples.

For details, refer to “Copying pamphlets (“Booklet Original” function)” on page 8-29.

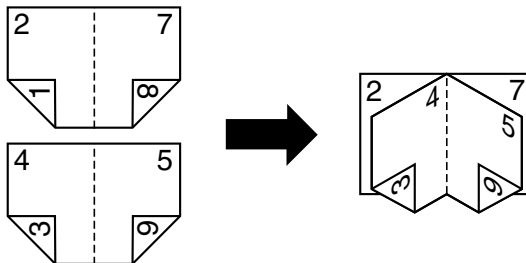

Repeating copy images

A document image can be repeatedly printed on a single sheet of paper.

For details, refer to “Tiling copy images (“Image Repeat” function)” on page 8-33.

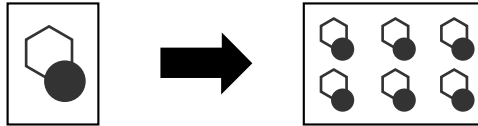

Printing the enlarged image on multiple pages

A single document page can be automatically split into parts with each part printed enlarged.

For details, refer to “Copying an enlarged image on multiple pages (“Poster Mode” function)” on page 8-38.

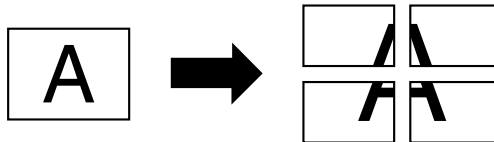

Making copies for filing

Copies can be printed with a filing margin so they can easily be stored in filing binders.

For details, refer to “Adding filing margins to copies (“Page Margin” function)” on page 8-58.

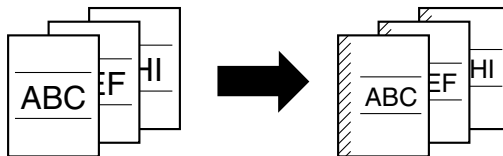

Copying with the page layout of a magazine

Copies can be made with the pages arranged in a layout for center binding, such as for a magazine.

For details, refer to “Copying with the page layout of a magazine (“Booklet” function)” on page 8-43.

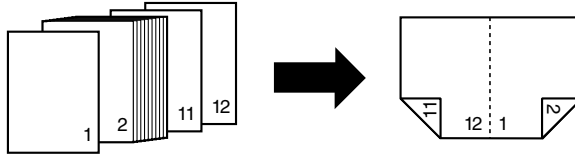

Erasing sections of copies

Areas, such as the shadows of punched holes and transmission information in received faxes, can be erased in copies.

For details, refer to “Erasing specified areas of copies (“Erase” function)” on page 8-61.

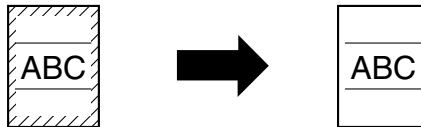

Adjusting the image to fit the paper size

When the copy paper is larger than the original document, copies can be printed so that the document image fills the paper.

For details, refer to “Adjusting the image to fit the paper (Image Adjustment settings)” on page 8-63.

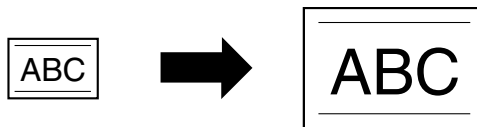

Printing distribution numbers or copy protection text on copies

Pages numbers or copy protection text (hidden text that prevents improper copying) can be printed on copies, or each copy set can be printed with distribution numbers.

For details, refer to “Printing the Date/Time, page number or distribution number on copies (Stamp functions)” on page 8-67.

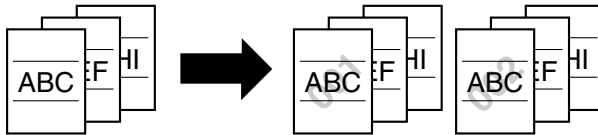

Managing jobs

The print status of copy jobs can be checked and the jobs can be managed.

For details, refer to “Managing jobs (Job List)” on page 11-2.

Programming copy settings

Frequently used copy settings can be programmed and recalled to be used with other copy jobs.

For details, refer to “Registering copy programs (Mode Memory)” on page 4-10.

Checking the copy settings

Screens showing the current copy settings can be displayed. From these screens, the copy settings can also be changed.

For details, refer to “Checking the copy settings (Mode Check)” on page 4-2.

Enlarging the size of text in touch panel screens

The text and buttons in the touch panel can be displayed in a larger size that is easier to read, allowing basic operations to be easily performed.

For details, refer to the Enlarge Display Operations of the User’s Guide.

Displaying explanations of functions and settings

The name and function of parts and details of functions and settings appears in the Help screens.

For details, refer to “Displaying function descriptions (Help)” on page 4-17.



Interrupting a copy job

The copy job being printed can be interrupted in order for a different copy job to be printed.

For details, refer to “Interrupting a copy job (Interrupt mode)” on page 4-8.





Printing a sample copy





Before printing a large number of copies, a single sample copy can be printed so that it can be checked.

For details, refer to “Printing a proof copy to be checked (Proof Copy)” on page 4-5.

Adjust color parameters

This section provides copy samples that are a helpful reference for setting the wide variety of parameters, functions and settings available with this full-color copier.

Section	Description	Section	Description
General Information About Color 	Provides information on hue, brightness and saturation (p. x-30)	"Contrast" Parameter 	Provides information on the adjustment of the contrast level (p. x-38)
"Red" Parameter 	Provides information on the adjustment of the red hues (p. x-32)	"Saturation" Parameter 	Provides information on the adjustment of the vividness (p. x-39)
"Green" Parameter 	Provides information on the adjustment of the green hues (p. x-33)	"Sharpness" Parameter 	Provides information on the adjustment of the sharpness of text (p. x-40)
"Blue" Parameter 	Provides information on the adjustment of the blue hues (p. x-34)	"Hue" Parameter 	Provides information on the adjustment of the hue (p. x-41)
"Color Balance" Parameter 	Provides information on the adjustment of the density of the colors CMYK (p. x-35)	"Copy Density" Parameter 	Provides information on the adjustment of the copy density (p. x-42)
"Brightness" Parameter 	Provides information on the adjustment of the brightness (p. x-37)	"Single Color" Function 	Provides information on copying with a single selected color (monotone) (p. x-43)

Section	Description	Section	Description
<p data-bbox="239 169 396 193">"2 Color" Function</p> 	<p data-bbox="456 169 620 277">Provides information on copying using only black and one selected color (p. x-44)</p>	<p data-bbox="646 169 822 213">"Neg-/Pos. Reverse" Function</p> 	<p data-bbox="863 169 1027 320">Provides information on copying a document with the light- and dark-colored areas of the image inverted (p. x-46)</p>
<p data-bbox="239 365 409 410">"Background Color" Function</p> 	<p data-bbox="456 365 620 474">Provides information on copying with the selected background color (p. x-45)</p>	<p data-bbox="646 365 844 389">"Mirror Image" Function</p> 	<p data-bbox="863 365 1027 496">Provides information on producing a copy in the mirror image of the original document (p. x-47)</p>

* Since the print samples provided are photographs, they may slightly differ in color with actual color copies.

General information about color

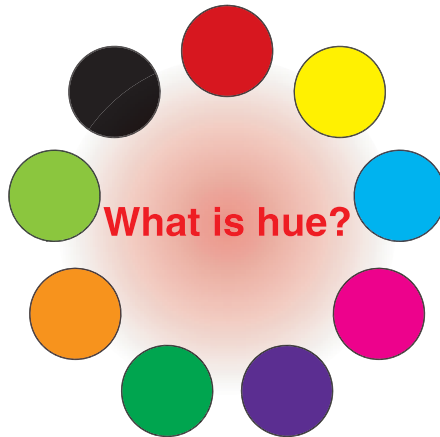

Everybody has an idea of what hue an object has, for example, an apple is red, a lemon is yellow, and the sky is blue. Hue is the tint by which the color of an object is classified as red, yellow, blue, etc.

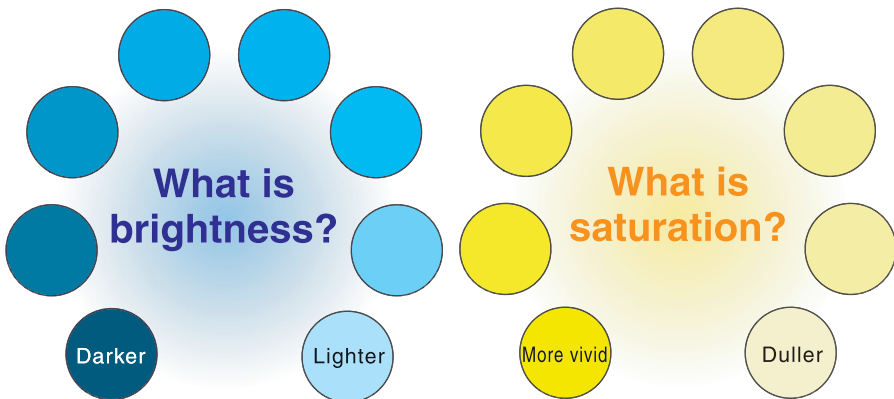

Brightness is the degree of lightness in a color, as compared with another color, which makes it a light color or a dark color. For example, when comparing the yellow of a lemon and the yellow of a grapefruit, it is obvious that the yellow of the lemon is brighter. But what about when comparing the yellow of a lemon and the red of a bean? Obviously, the yellow of the lemon is brighter. Brightness is this degree of lightness that enables comparison regardless of the hue.

What makes the difference between the yellow of a lemon and the yellow of a pear? By saying that the lemon is a more vivid yellow and the pear is a duller yellow, the difference between the two colors is stated in terms of saturation, as opposed to brightness. As opposed to hue and brightness, saturation is the characteristic that indicates the degree of vividness.

Relationship between hue, brightness and saturation (color model)

Hue, brightness and saturation are the elements that we call the “three attributes of color”. We can think of their affects using the solid object shown in figure 1, where the outer edge is the hue, the vertical axis is the brightness, and the horizontal axis from the center is the saturation.

Assigning colors to the solid object, representing the three attributes of color, shown in figure 1 produces the color model shown in figure 2. Although the level of saturation differs for each hue and degree of brightness, creating a complex color model, we can get a better understanding of the conditions under which the hue, brightness and saturation vary.

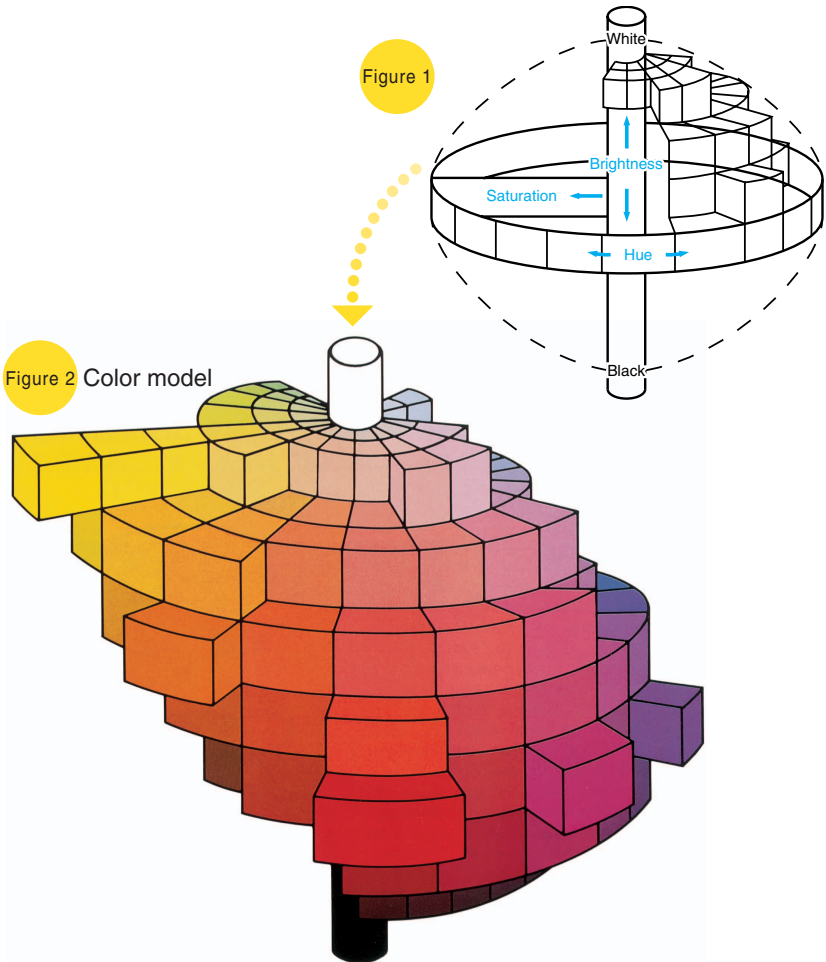

“Red” parameter

This parameter can be used to adjust the degree of red in the image to one of 19 levels.

For details on the setting procedure, refer to page 8-53.

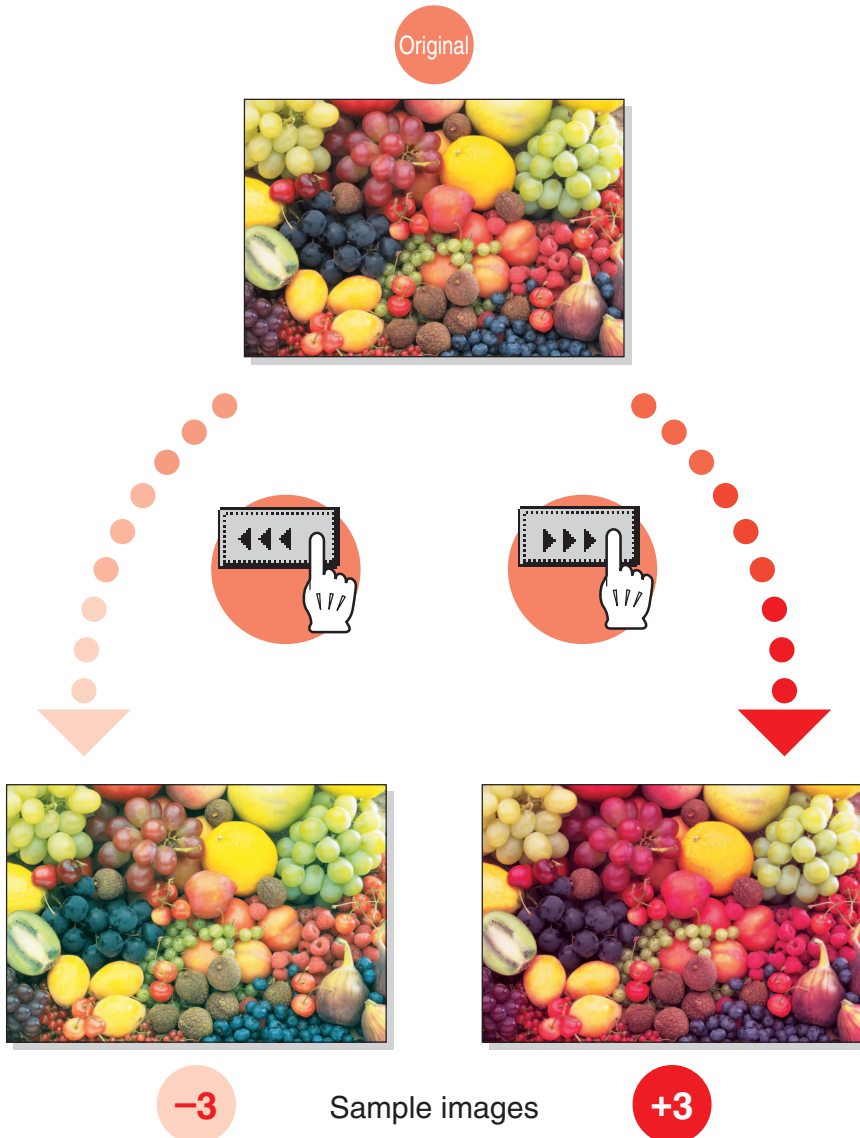

“Green” parameter

This parameter can be used to adjust the degree of green in the image to one of 19 levels.

For details on the setting procedure, refer to page 8-53.

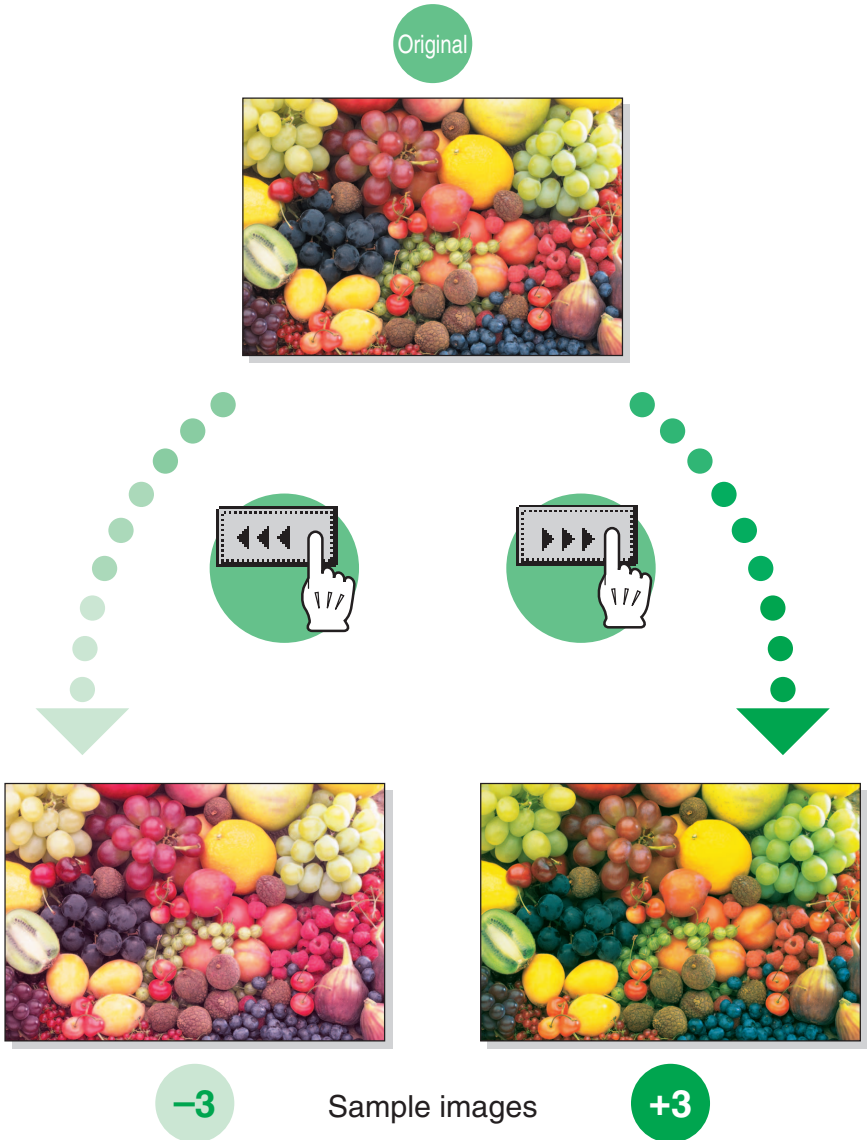

“Blue” parameter

This parameter can be used to adjust the degree of blue in the image to one of 19 levels.

For details on the setting procedure, refer to page 8-53.

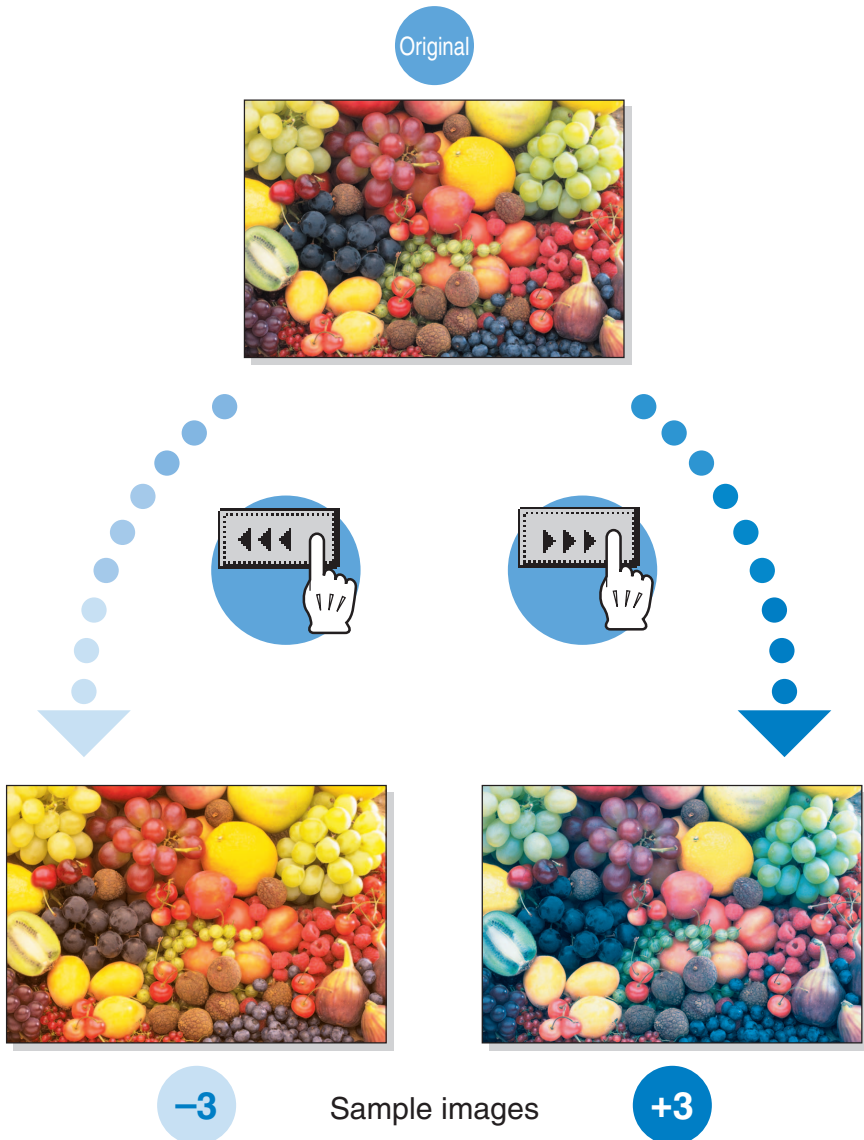



“Color Balance” parameter (CMYK color adjustment)

By mixing the four toner colors (yellow, magenta, and cyan in addition to black) in a full-color copy, the colors of the document can be reproduced.

Changing the amount of each color of toner enables the tints in the copy to be finely adjusted. Each color can be adjusted to any of 19 levels.

For details on the setting procedure, refer to page 8-53.

Adjusting the black tinge

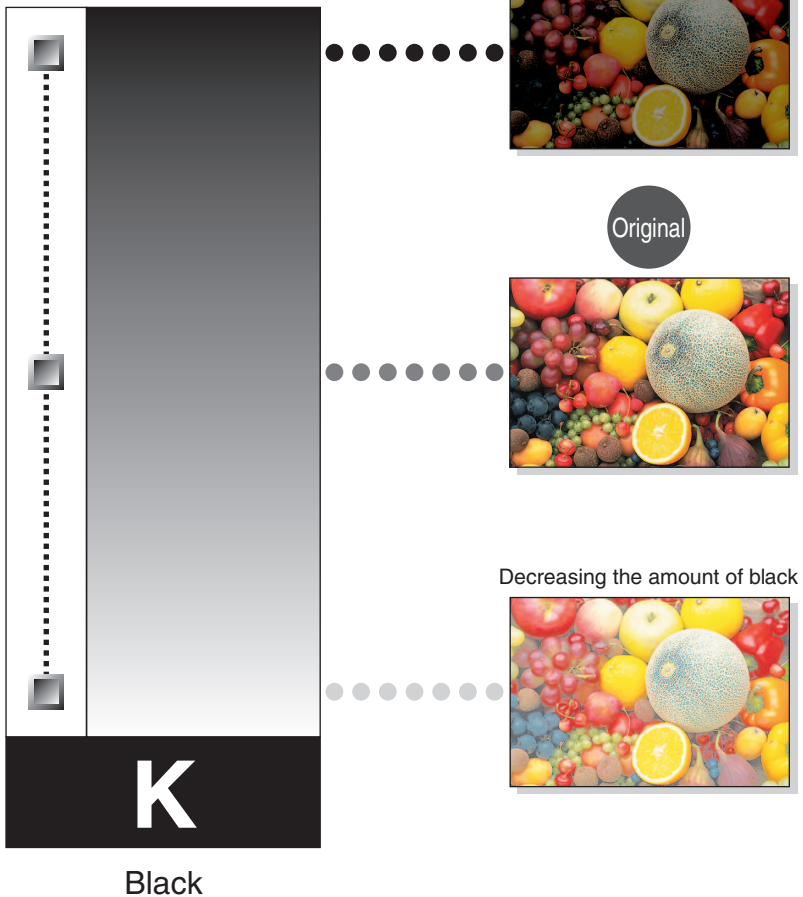

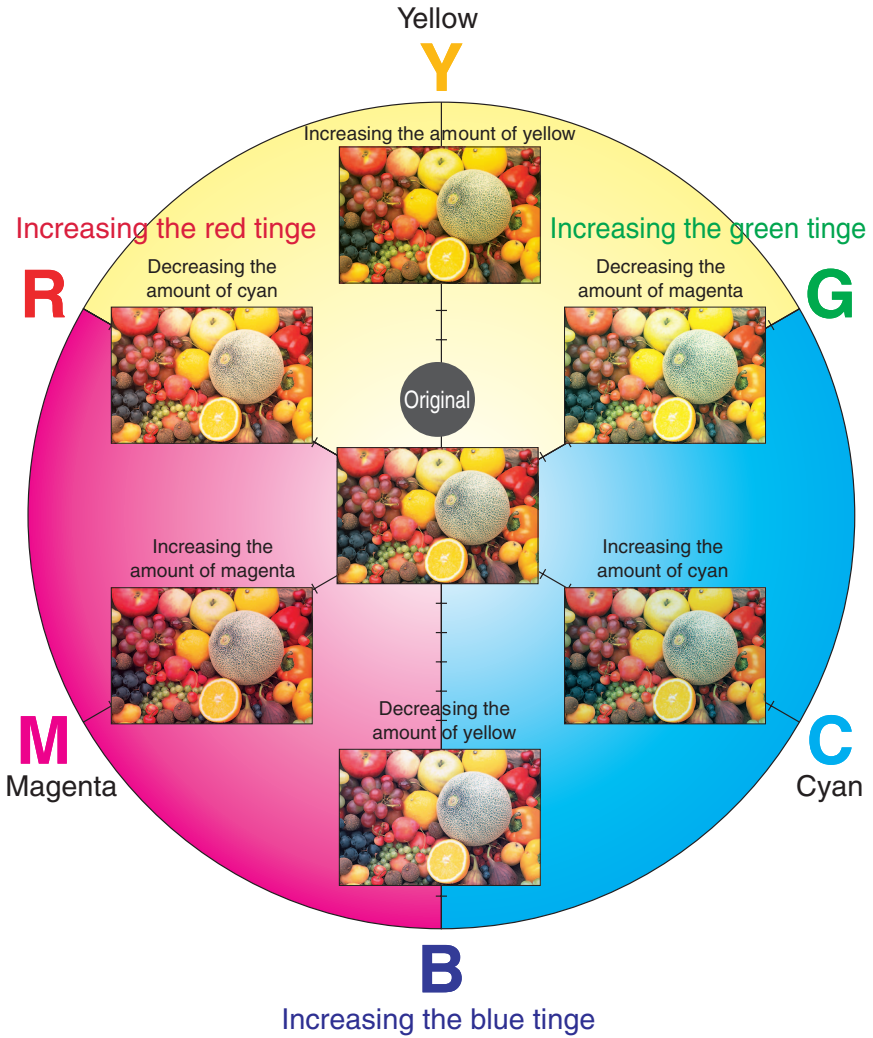



“Brightness” parameter

This parameter can be used to finely adjust the brightness of the image to one of 19 levels.

For details on the setting procedure, refer to page 8-53.

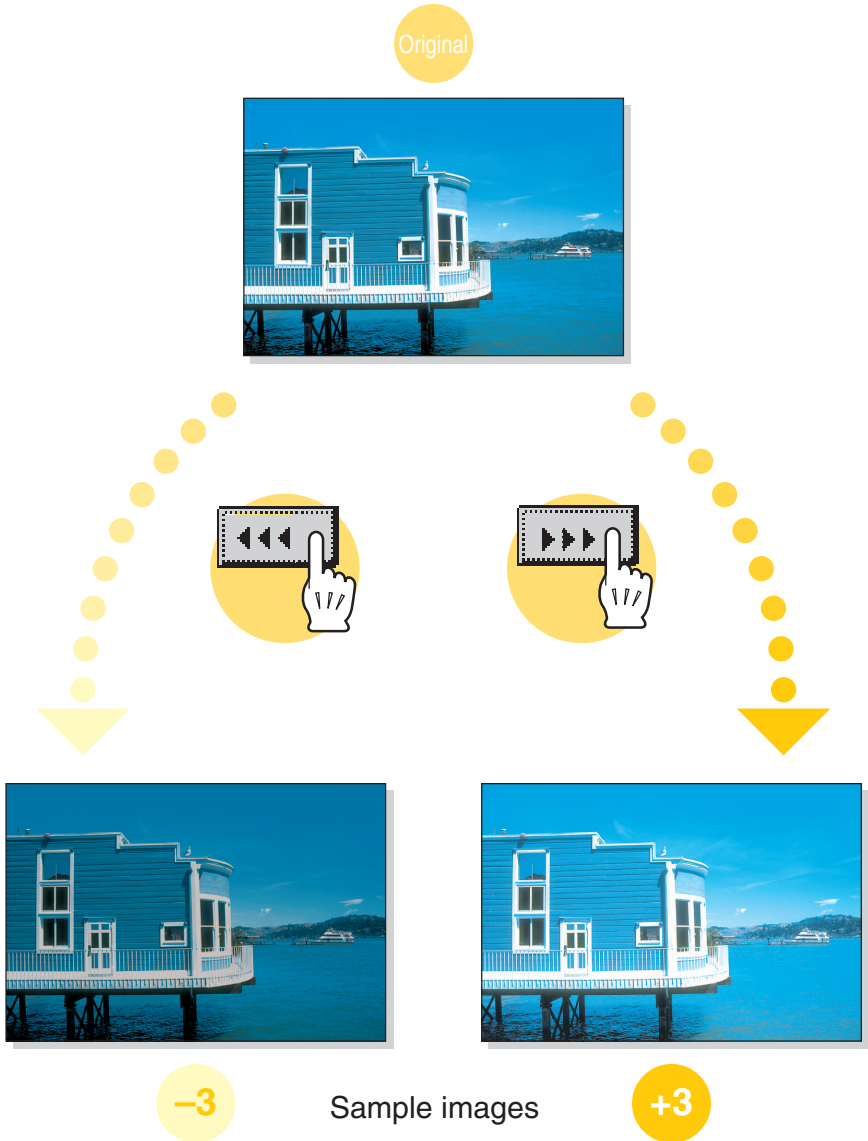

“Contrast” parameter

This parameter can be used to finely adjust the image to one of 19 levels between soft/smooth and crisp.

For details on the setting procedure, refer to page 8-53.

Original



-3

Sample images

+3



“Saturation” parameter

This parameter can be used to finely adjust the vividness of the image to one of 19 levels.

For details on the setting procedure, refer to page 8-53.

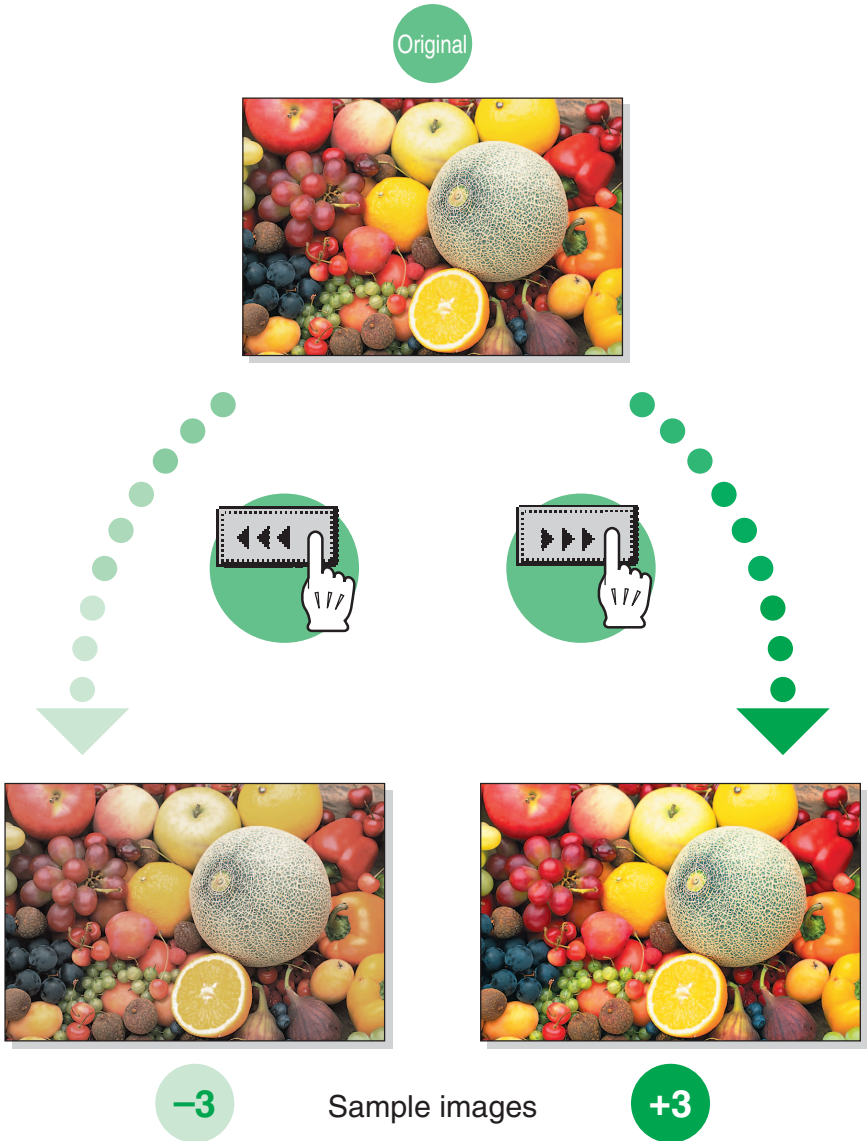

“Sharpness” parameter

This parameter can be used to adjust the amount of contours in text and images to one of 7 levels.

For details on the setting procedure, refer to page 8-53.

Original

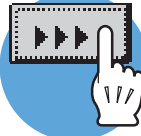
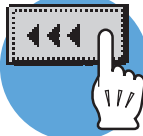

-3

Sample images

+3



“Hue” parameter

This parameter can be used to finely adjust the hue of the image to one of 19 levels.

For details on the setting procedure, refer to page 8-53.

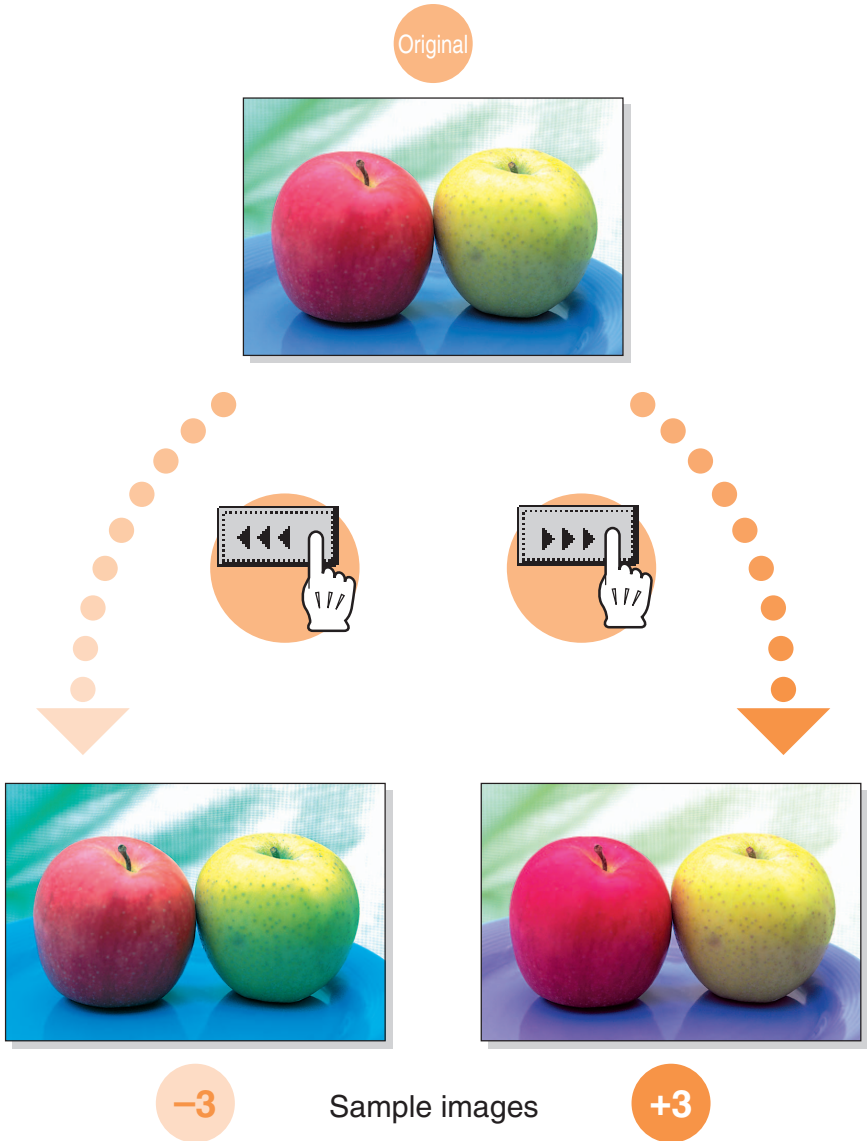

“Copy Density” parameter

This parameter can be used to finely adjust the light and shading of the image to one of 19 levels.

For details on the setting procedure, refer to page 8-53.

Original

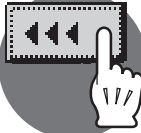

-3

Sample images

+3





“Single Color” function

This function allows you to copy a document using only one of the 21 colors available.

For details on the setting procedure, refer to page 3-32.



“2 Color” function

This setting allows you to produce copies with the black areas of the document printed in black and the color areas of the document printed in one of the six colors available.

For details on the setting procedure, refer to page 3-32.

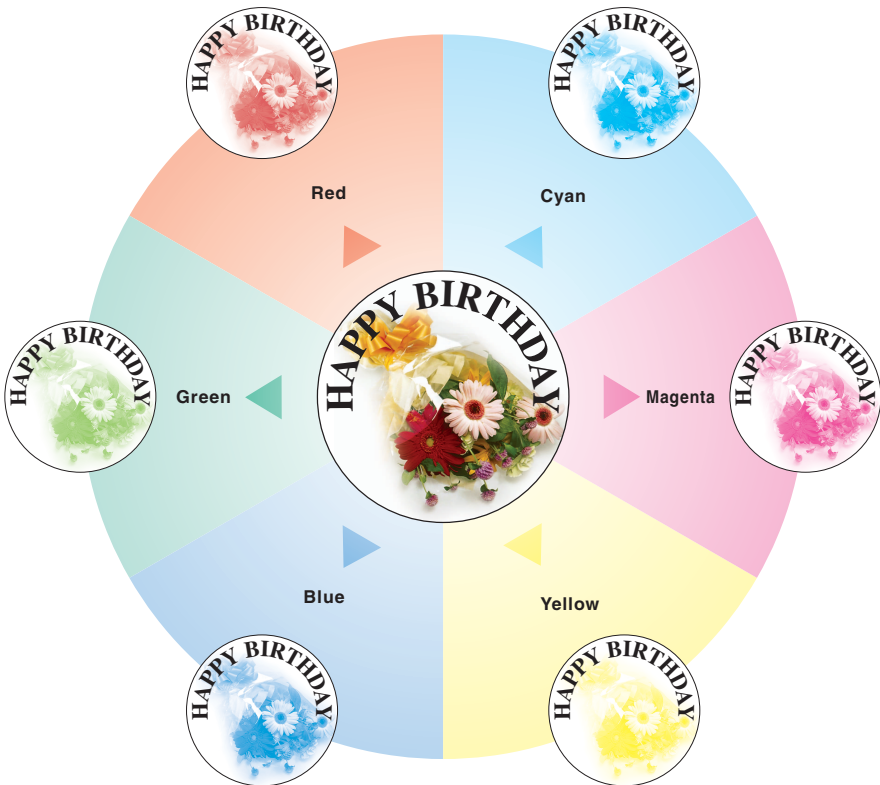

“Background Color” function

This function allows you to copy a document using one of the 18 colors available as the color of the background (blank areas).

For details on the setting procedure, refer to page 8-51.

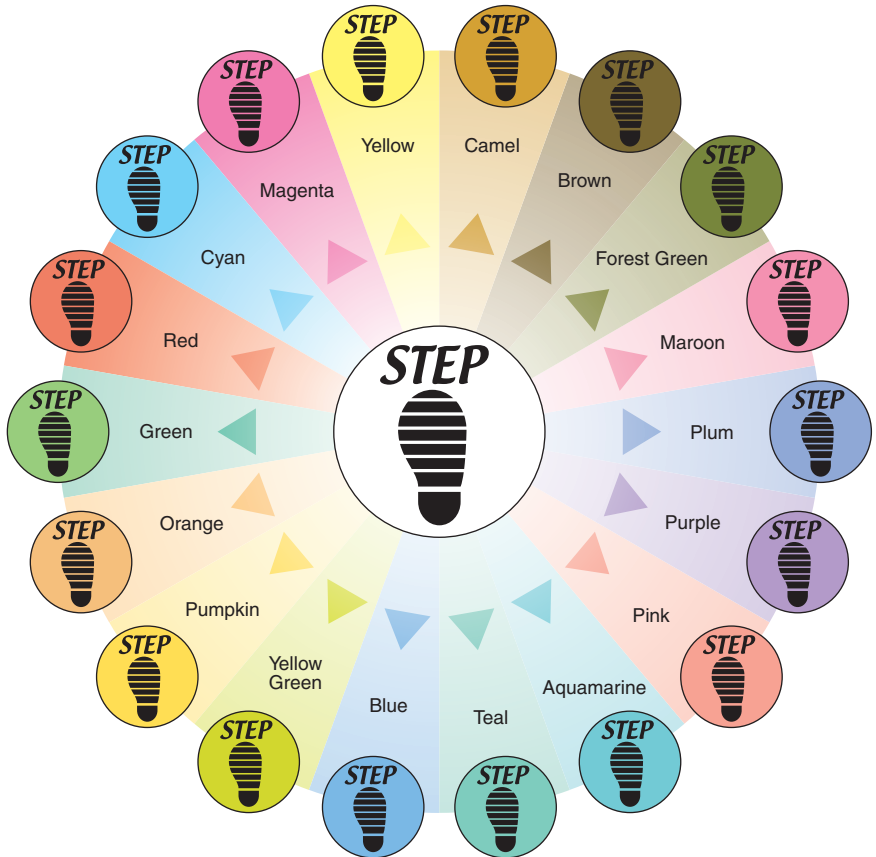

“Neg-/Pos. Reverse” function

This function allows you to copy a document with the light-colored areas and the dark-colored areas of the image inverted.

For details on the setting procedure, refer to page 8-45.

Monotone copy



Full-color copy and “Background Color” function



“Mirror Image” function

This function allows you to copy a mirror image of the original document.
For details on the setting procedure, refer to page 8-47.



Explanation of manual conventions

Titles indicate the contents of the section.

Text that appears in this manner describes the function limitations and options required to use certain functions.

Text that appears in this manner describes supplemental information, such as precautions, references and actions, relating to steps.

Text that appears in this manner provides answers to problems and questions that may occur during operation.

Application functions

8.6 Producing separate copies of each page in a page spread (Book Copy function)

A page spread, such as in an open book or catalog, can be copied with the left and right pages on separate pages or both on the same page.

To copy using the Book Copy function

- ✓ Place the original on the original glass.

⚠ CAUTION

Handling toner and the toner cartridges

- Do not throw toner or the toner cartridge into a fire.
- Toner expelled from the fire may cause burns.

- 1 Place the pages on the original glass, starting with the first page.
 - For details on positioning the original, refer to Feeding the original on page 3-7.
 - To add copies of the covers, load them first.
 - How are the front and back covers copied?
 - Scan the front cover, then the back cover, and then scan the remainder of the original.
- 2 Load the paper to be used into the desired paper tray.
- 3 Touch [Application], and then touch [Book Copy/Repeat].
 - To cancel all settings for the Application functions, touch [Reset].



The Book Copy/Repeat screen appears.

Chapter 8
Application functions

⚠ WARNING , CAUTION

⚠ WARNING , CAUTION

Text highlighted in this manner indicates precautions to ensure safe use of this machine. “Warning” indicates instructions that, when not observed, may result in fatal or critical injuries. “Caution” indicates instructions that, when not observed, may result in serious injuries or property damage.

(The page shown above is an example only.)



[] Names highlighted as shown above indicate keys on the control panel, buttons in the touch panel, and the power switches.

Chapter 8 Application functions

4 Touch [Book Copy].

Touch panel screens are shown to check the actual display.

The Book Scanning screen appears. [Booklet Original] is not available if optional saddle stitcher is not installed.

5 Touch the button for the desired setting.

Reminder
Do not replace the toner cartridge until the message *There is no Toner...* appears. In addition, do not replace the toner cartridge of any color other than the one indicated in the message on the touch panel.

Note
Even though the setting can be specified in increments of 1/3, the setting will appear at the nearest full increment in the Adjust Color screen.

Detail
If the *Single Color* function is set, the colors are inverted with the selected color. If the *Background Color* function is set, the colors, including the selected background color, are inverted.

8-22 C252

Reminder
Text highlighted in this manner indicates operation precautions. Carefully read and observe this type of information.

Note
Text highlighted in this manner contains references and supplemental information concerning operating procedures and other descriptions. We recommend that this information be read carefully.

(The page shown above is an example only.)

Descriptions and symbols for documents and paper

The use of words and symbols in this manual are explained below.

“Width” and “Length”

Whenever paper dimensions are mentioned in this manual, the first value always refers to the width of the paper (shown as “Y” in the illustration) and the second to the length (shown as “X”).

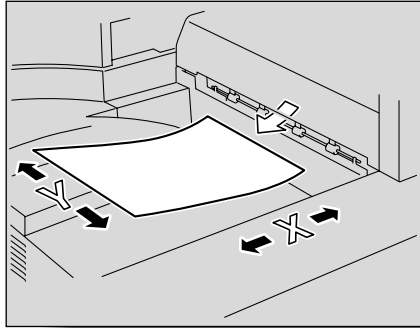

Paper Orientation

Lengthwise (☐)

If the width (Y) of the paper is shorter than the length (X), the paper has a vertical or portrait orientation, indicated by ☐.

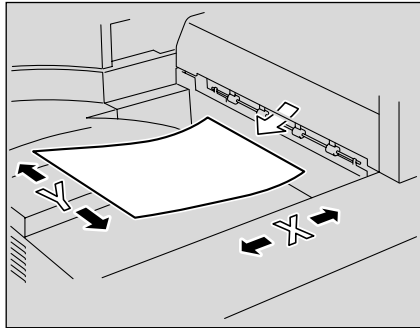

Crosswise (☐)

If the width (Y) of the paper is longer than the length (X), the paper has a horizontal or landscape orientation, indicated by ☐.

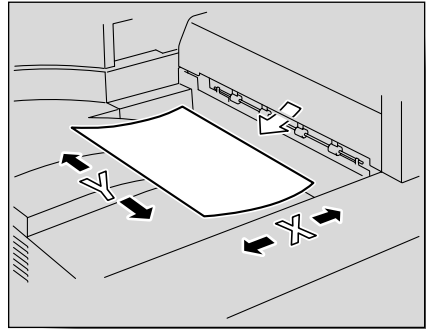

User's Guides

The following User's Guides have been prepared for this machine.

User's Guide [Copy Operations] <this manual>

This manual contains details on basic operations and the operating procedures for the various copy functions.

- Refer to this User's Guide for details on operating procedures for copy functions, including precautions on installation/use, turning the machine on/off, loading paper, and troubleshooting operations such as clearing paper misfeeds.

User's Guide [Network Scanner Operations]

This manual contains details on specifying network settings for standard equipment and on operations for scanning functions.

- Refer to this User's Guide for details on operating procedures for network functions and for using Scan to E-Mail, Scan to FTP and Scan to SMB.

User's Guide [Box Operations]

This manual contains details on operating procedures for using the boxes.

- Refer to this User's Guide for details on operating procedures for using the boxes on the hard disk.

User's Guide [Enlarge Display Operations]

This manual contains details on operating procedures for using copy, network scanner and fax functions in Enlarge Display mode.

- Refer to this User's Guide for details on operating procedures in Enlarge Display mode.

User's Guide [FK-502 Facsimile Operations]

This manual contains details on operating procedures for faxing.

- Refer to this User's Guide for details on operating procedures for fax functions when the fax kit is installed.

User's Guide [Network Facsimile Operations]

This manual contains details on operating procedures for network faxing.

- Refer to this User's Guide for details on operating procedures for using the network fax functions (Internet faxing, SIP faxing and IP address faxing).

User's Guide [Print Operations]

This manual contains details on operating procedures using the standard built-in printer controller.

- For details on the printing functions, refer to User's Guide (PDF file) on User Software CD-ROM.

Quick Guide [Print Operations]

This manual contains details on operating procedures using the standard built-in printer controller.

- Refer to this User's Guide for basic operating procedures for the printing functions.

Legal restrictions on copying

Certain types of documents must never be copied with the purpose or intent to pass copies of such documents off as the originals.

The following is not a complete list, but is meant to be used as a guide to responsible copying.

<Financial Instruments>

- Personal checks
- Traveler's checks
- Money orders
- Certificates of deposit
- Bonds or other certificates of indebtedness
- Stock certificates

<Legal Documents>

- Food stamps
- Postage stamps (canceled or uncanceled)
- Checks or drafts drawn by government agencies
- Internal revenue stamps (canceled or uncanceled)
- Passports
- Immigration papers
- Motor vehicle licenses and titles
- House and property titles and deeds

<General>

- Identification cards, badges, or insignias
- Copyrighted works without permission of the copyright owner

In addition, it is prohibited under any circumstances to copy domestic or foreign currencies, or works of art without permission of the copyright owner.

When in doubt about the nature of a document, consult with legal counsel.



Detail

In order to prohibit the illegal reproduction of certain documents, such as paper currency, this machine is equipped with a counterfeit prevention feature.

Due to the counterfeit prevention feature that this machine is equipped with, images may be distorted.



Installation and operation precautions

1 Installation and operation precautions

1.1 Safety information

This section contains detailed instructions on the operation and maintenance of this machine. To achieve optimum utility of this device, all operators should carefully read and follow the instructions in this manual.

Please read the following section before connecting the machine to the supply. It contains important information related to user safety and preventing equipment problems.

Please keep this manual in a handy place near the machine.

Make sure you observe all of the precautions appear in each section of this manual.

KM_Ver.01E_C





Note

Some parts of the contents of this section may not correspond with the purchased product.

Warning and precaution symbols

The following indicators are used on the warning labels or in this manual to categorize the level of safety warnings.

 WARNING	Ignoring this warning could cause serious injury or even death.
 CAUTION	Ignoring this caution could cause injury or damage to property.

Meaning of symbols



A triangle indicates a danger against which you should take precaution.



This symbol warns against cause burns.



A diagonal line indicates a prohibited course of action.



This symbol warns against dismantling the device.





A solid circle indicates an imperative course of action.





This symbol indicates you must unplug the device.

Disassemble and modification**⚠ WARNING**

- Do not attempt to remove the covers and panels which have been fixed to the product. Some products have a high-voltage part or a laser beam source inside that could cause an electrical shock or blindness. 
- Do not modify this product, as a fire, electrical shock, or breakdown could result. If the product employs a laser, the laser beam source could cause blindness. 

Power cord**⚠ WARNING**

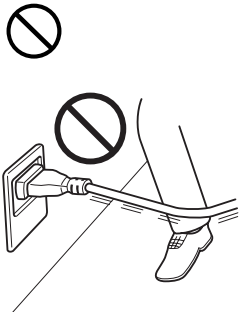
- Use only the power cord supplied in the package. If a power cord is not supplied, only use the power cord and plug that is specified in POWER CORD INSTRUCTION. Failure to use this cord could result in a fire or electrical shock. 
- Use the power cord supplied in the package only for this machine and NEVER use it for any other product. Failure to observe this precaution could result in a fire or electrical shock. 
- Do not scratch, abrade, place a heavy object on, heat, twist, bend, pull on, or damage the power cord. Use of a damaged power cord (exposed core wire, broken wire, etc.) could result in a fire or breakdown. Should any of these conditions be found, immediately turn OFF the power switch, unplug the power cord from the power outlet, and then call your authorized service representative. 

Power source** WARNING**

- Use only the specified power source voltage. Failure to do that could result in a fire or electrical shock. 

- Connect power plug directly into wall outlet having the same configuration as the plug. Use of an adapter leads to the product connecting to inadequate power supply (voltage, current capacity, grounding), and may result in fire or shock. If proper wall outlet is not available, the customer shall ask qualified electrician for the installation. 

- Do not use a multiple outlet adapter nor an extension cord in principle. Use of an adapter or an extension cord could cause a fire or electrical shock. Contact your authorized service representative if an extension cord is required. 

- Consult your authorized service representative before connecting other equipment on the same wall outlet. Overload could result in a fire. 

 CAUTION

- The outlet must be near the equipment and easily accessible. Otherwise you can not pull out the power plug when an emergency occurs. 

Power plug **WARNING**

- Do not unplug and plug in the power cord with a wet hand, as an electrical shock could result.



- Plug the power cord all the way into the power outlet. Failure to do this could result in a fire or electrical shock.

 **CAUTION**

- Do not tug the power cord when unplugging. Pulling on the power cord could damage the cord, resulting in a fire or electrical shock.



- Remove the power plug from the outlet more than one time a year and clean the area between the plug terminals. Dust that accumulates between the plug terminals may cause a fire.

**Grounding** **WARNING**





- Connect the power cord to an electrical outlet that is equipped with a grounding terminal.

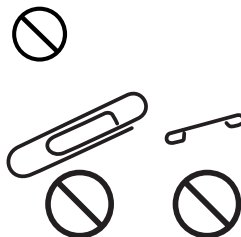

Installation**⚠ WARNING**

- Do not place a flower vase or other container that contains water, or metal clips or other small metallic objects on this product. Spilled water or metallic objects dropped inside the product could result in a fire, electrical shock, or breakdown.
Should a piece of metal, water, or any other similar foreign matter get inside the product, immediately turn OFF the power switch, unplug the power cord from the power outlet, and then call your authorized service representative.

**⚠ CAUTION**

- After installing this product, mount it on a secure base. If the unit moves or falls, it may cause personal injury. 
- Do not place the product in a dusty place, or a site exposed to soot or steam, near a kitchen table, bath, or a humidifier. A fire, electrical shock, or breakdown could result. 
- Do not place this product on an unstable or tilted bench, or in a location subject to a lot of vibration and shock. It could drop or fall, causing personal injury or mechanical breakdown. 
- Do not let any object plug the ventilation holes of this product. Heat could accumulate inside the product, resulting in a fire or malfunction. 
- Do not use flammable sprays, liquids, or gases near this product, as a fire could result. 

Ventilation**⚠ CAUTION**

- Always use this product in a well ventilated location. Operating the product in a poorly ventilated room for an extended period of time could injure your health. Ventilate the room at regular intervals.

**Actions in response to troubles****⚠ WARNING**

- Do not keep using this product, if this product becomes inordinately hot or emits smoke, or unusual odor or noise. Immediately turn OFF the power switch, unplug the power cord from the power outlet, and then call your authorized service representative. If you keep on using it as is, a fire or electrical shock could result.
- Do not keep using this product, if this product has been dropped or its cover damaged. Immediately turn OFF the power switch, unplug the power cord from the power outlet, and then call your authorized service representative. If you keep on using it as is, a fire or electrical shock could result.

**⚠ CAUTION**

- The inside of this product has areas subject to high temperature, which may cause burns. When checking the inside of the unit for malfunctions such as a paper misfeed, do not touch the locations (around the fusing unit, etc.) which are indicated by a “Caution HOT” caution label.



Consumables**⚠ WARNING**

- Do not throw the toner cartridge or toner into an open flame. The hot toner may scatter and cause burns or other damage.

**⚠ CAUTION**

- Do not leave a toner unit or drum unit in a place within easy reach of children. Licking or ingesting any of these things could injure your health.
- Do not store toner units and PC drum units near a floppy disk or watch that are susceptible to magnetism. They could cause these products to malfunction.

**When moving the machine****⚠ CAUTION**

- Whenever moving this product, be sure to disconnect the power cord and other cables. Failure to do this could damage the cord or cable, resulting in a fire, electrical shock, or breakdown.
- When moving this product, always hold it by the locations specified in the User's Guide or other documents. If the unit falls it may cause severe personal injury. The product may also be damaged or malfunction.



When the optional Fax Kit FK-502 is not installed:

Before successive holidays**⚠ CAUTION**

- Unplug the product when you will not use the product for long periods of time.



1.2 Regulation notices

CE Marking (Declaration of Conformity) for users of the European Union (EU)

This product complies with the following EU directives: 89/336/EEC, 73/23/EEC and 93/68/EEC directives.

This declaration is valid for the area of the European Union.

This device must be used with a shielded network (10 Base-T/100 Base-TX) cable and a shielded parallel cable. The use of non-shielded cables is likely to result in interference with radio communications and is prohibited under CISPR rules and local rules.

USER INSTRUCTIONS FCC PART 15 - RADIO FREQUENCY DEVICES (for U.S.A. users)

NOTE: This equipment has been tested and found to comply with the limits for a Class A digital device, pursuant to Part 15 of the FCC Rules.

These limits are designed to provide reasonable protection against harmful interference when the equipment is operated in a commercial environment. This equipment generates, uses and can radiate radio frequency energy and, if not installed and used in accordance with the instruction manual, may cause harmful interference to radio communications. Operation of this equipment in a residential area is likely to cause harmful interference in which case the user will be required to correct the interference at his own expense.

WARNING: The design and production of this unit conform to FCC regulations, and any changes or modifications must be registered with the FCC and are subject to FCC control. Any changes made by the purchaser or user without first contacting the manufacturer will be subject to penalty under FCC regulations.

This device must be used with a shielded network (10 Base-T/100 Base-TX) cable and a shielded parallel cable. The use of non-shielded cables is likely to result in interference with radio communications and is prohibited under FCC rules.

INTERFERENCE-CAUSING EQUIPMENT STANDARD (ICES-003 ISSUE 4) (for Canada users)

This Class A digital apparatus complies with Canadian ICES-003.

Cet appareil numérique de la classe A est conforme à la norme NMB-003 du Canada.

For users in countries not subject to class B regulations**WARNING**

This is a Class A product. In a domestic environment this product may cause radio interference in which case the user may be required to take adequate measures.

This device must be used with a shielded network (10 Base-T/100 Base-TX) cable and a shielded parallel cable. The use of non-shielded cables is likely to result in interference with radio communications and is prohibited under CISPR rules and local rules.

Laser safety

This is a digital machine which operates using a laser. There is no possibility of danger from the laser provided the machine is operated according to the instructions in this manual.

Since radiation emitted by the laser is completely confined within protective housing, the laser beam cannot escape from the machine during any phase of user operation.

This machine is certified as a Class 1 laser product: This means the machine does not produce hazardous laser radiation.

Internal laser radiation

Maximum Average Radiation Power: 8.0 μ W at the laser aperture of the print head unit.

Wavelength: 775-800 nm

This product employs a Class 3B laser diode that emits an invisible laser beam.

The laser diode and the scanning polygon mirror are incorporated in the print head unit.

The print head unit is NOT A FIELD SERVICE ITEM:

Therefore, the print head unit should not be opened under any circumstances.

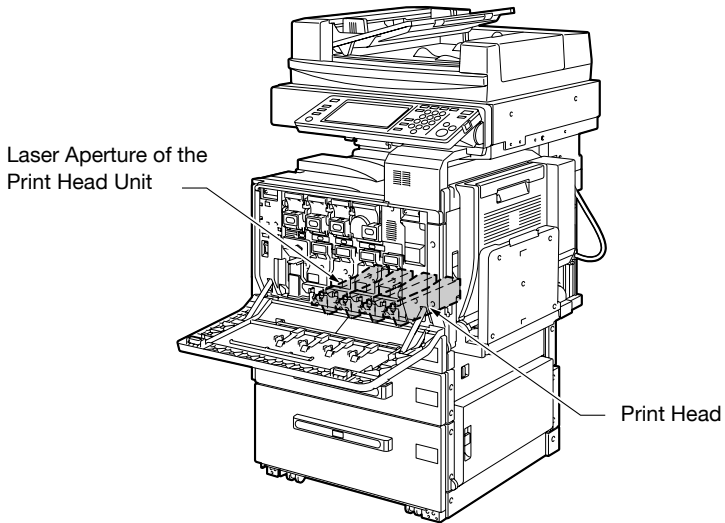

CDRH regulations

This machine is certified as a Class 1 Laser product under Radiation Performance Standard according to the Food, Drug and Cosmetic Act of 1990. Compliance is mandatory for Laser products marketed in the United States and is reported to the Center for Devices and Radiological Health (CDRH) of the U.S. Food and Drug Administration of the U.S. Department of Health and Human Services (DHHS). This means that the device does not produce hazardous laser radiation.

The label shown on page 1-14 indicates compliance with the CDRH regulations and must be attached to laser products marketed in the United States.

CAUTION

Use of controls, adjustments or performance of procedures other than those specified in this manual may result in hazardous radiation exposure.

This is a semiconductor laser. The maximum power of the laser diode is 10 mW and the wavelength is 775-800 nm.

For European users

CAUTION

Use of controls, adjustments or performance of procedures other than those specified in this manual may result in hazardous radiation exposure.

This is a semiconductor laser. The maximum power of the laser diode is 10 mW and the wavelength is 775-800 nm.

For Denmark users

ADVARSEL

Usynlig laserstråling ved åbning, når sikkerhedsafbrydere er ude af funktion. Undgå udsættelse for stråling. Klasse 1 laser produkt der opfylder IEC60825 sikkerheds kravene.

Dansk: Dette er en halvlederlaser. Laserdiodens højeste styrke er 10 mW og bølglængden er 775-800 nm.

For Finland, Sweden users

LOUKAN 1 LASERLAITE

KLASS 1 LASER APPARAT

VAROITUS!

Laitteen Käyttäminen muulla kuin tässä käyttöohjeessa mainitulla tavalla saattaa altistaa käyttäjän turvallisuusluokan 1 ylittävälle näkymättömälle lasersäteilylle.

Tämä on puolijohdelaser. Laserdiodin sunrin teho on 10 mW ja aallonpituus on 775-800 nm.

WARNING!

Om apparaten används på annat sätt än i denna bruksanvisning specificerats, kan användaren utsättas för osynlig laserstrålning, som överskrider gränsen för laserklass 1.

Det här är en halvlederlaser. Den maximala effekten för laserdioden är 10 mW och våglängden är 775-800 nm.

VARO!

Avattaessa ja suojalukitus ohitettaessa olet alttiina näkymättömälle lasersäteilylle. Älä katso säteeseen.

WARNING!

Osynlig laserstrålning när denna del är öppnad och spärren är urkopplad. Betrakta ej strålen.

For Norway users

ADVARSEL

Dersom apparatet brukes på annen måte enn spesifisert i denne bruksanvisning, kan brukeren utsettes for usynlig laserstråling som overskrider grensen for laser klass 1.

Dette en halvleder laser. Maksimal effekt till laserdiode er 10 mW og bølglengde er 775-800 nm.

Laser safety label

A laser safety label is attached to the outside of the machine, as shown below.

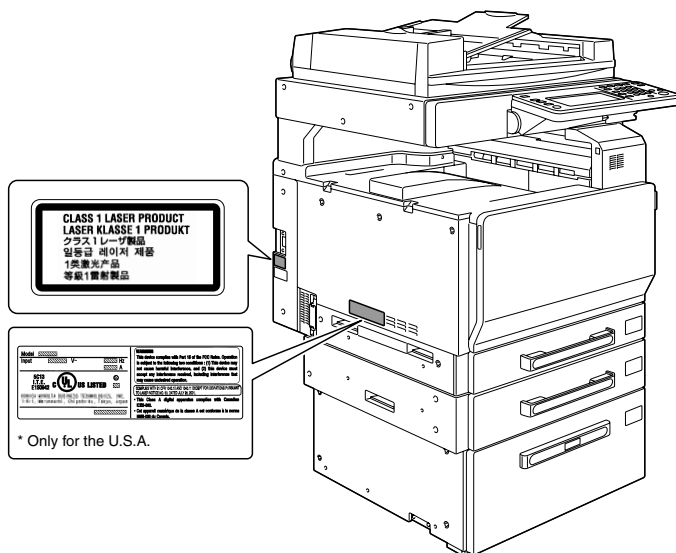

Ozone release

Locate the Machine in a Well-Ventilated Room

A negligible amount of ozone is generated during normal operation of this machine. An unpleasant odor may, however, be created in poorly ventilated rooms during extensive machine operations. For a comfortable, healthy and safe operating environment, it is recommended that the room be well ventilated.

Placer l'appareil dans une pièce largement ventilée

Une quantité d'ozone négligeable est dégagée pendant le fonctionnement de l'appareil quand celui-ci est utilisé normalement. Cependant, une odeur désagréable peut être ressentie dans les pièces dont l'aération est insuffisante et lorsque une utilisation prolongée de l'appareil est effectuée. Pour avoir la certitude de travailler dans un environnement réunissant des conditions de confort, santé et de sécurité, il est préférable de bien aérer la pièce ou se trouve l'appareil.

Acoustic noise (for European users only)

Maschinenlärminformations-Verordnung 3. GPSGV: Der höchste Schalldruckpegel beträgt 70 dB(A) oder weniger gemäss EN ISO 7779.

Recycling batteries (For Taiwan Users Only)

根據地方規定處理使用的電池。

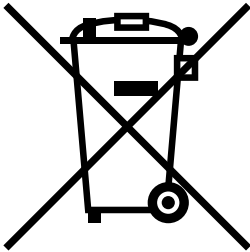
**For EU member states only**

This symbol means: Do not dispose of this product together with your household waste!

Please refer to the information of your local community or contact our dealers regarding the proper handling of end-of-life electric and electronic equipments. Recycling of this product will help to conserve natural resources and prevent potential negative consequences for the environment and human health caused by inappropriate waste handling.

For EU member states only

This product complies with RoHS (2002/95/EC) Directive.

1.4 Space requirements

To ensure that machine operation, consumables replenishing, part replacement, and regular maintenance can easily be performed, adhere to the recommended space requirements detailed below.

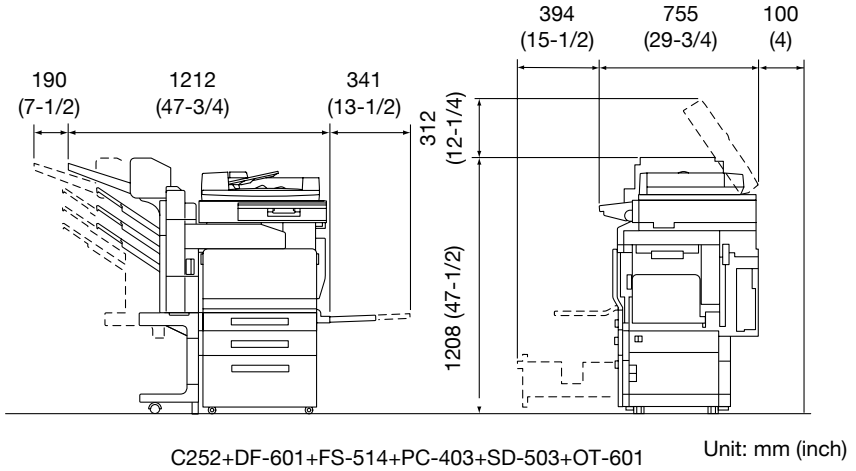

Reminder

Be sure to allow a clearance of 100 mm (4 in.) or more at the back of this machine for the ventilation duct.

1.5 Operation precautions

To ensure the optimum performance of this machine, observe the precautions described below.

Power source

The power source requirements are as follows.

- Voltage fluctuation: Maximum $\pm 10\%$ (at 110 V/120 to 127 V/220 to 240 V AC)
- Frequency fluctuation: Maximum ± 3 Hz (at 50 Hz/60 Hz)
- Use a power source with as little voltage or frequency fluctuations as possible.

Operating environment

The environmental requirements for correct operation of the machine are as follows.

- Temperature: 10°C (50°F) to 30°C (86°F) with fluctuations of no more than 10°C (18°F) within an hour
- Humidity: 15% to 85% with fluctuations of no more than 20% within an hour

Storage of copies

To store copies, follow the recommendation listed below.

- Copies that are to be kept for a long time should be kept where they are not exposed to light in order to prevent them from fading.
- Adhesive that contains solvent (e.g., spray glue) may dissolve the toner on copies.
- Color copies have a thicker layer of toner than normal black-and-white copies. Therefore, when a color copy is folded, the toner at the fold may peel off.



Before making copies

2 Before making copies

2.1 Part names and their functions

Options

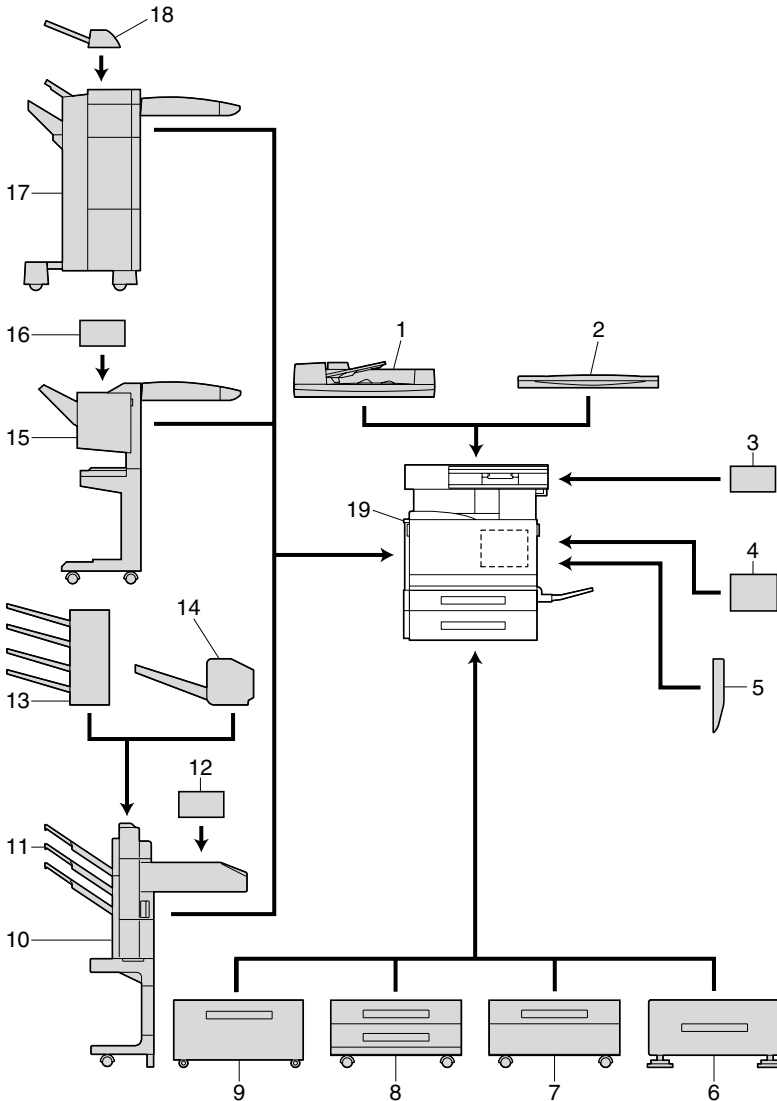

No.	Part Name	Description
1	Automatic Document Feeder DF-601	Automatically feeds one document sheet at a time for scanning, and automatically turns over double-sided documents for scanning Referred to as the "ADF" throughout the manual.
2	Original Cover OC-501	Presses down on the loaded document to keep it in place Referred to as the "original cover" throughout the manual.
3	Working Table WT-501	Provides an area to temporarily place a document or other materials
4	Fax Multi Line ML-501	Installed to increase the telephone lines available for faxing
5	Automatic Duplex Unit AD-503	Turns over printed pages, allowing double-sided pages to be printed automatically Required to print on letterhead paper Referred to as the "automatic duplex unit" throughout the manual.
6	Desk DK-502	Allows this machine to be set up on the floor Referred to as the "desk" throughout the manual.
7	Paper Feed Cabinet PC-103	The top tray can be loaded with up to 500 sheets of paper, and the bottom tray can be used as storage. Referred to as the "single paper feed cabinet" throughout the manual.
8	Paper Feed Cabinet PC-203	Both the top and bottom trays can each be loaded with up to 500 sheets of paper. Referred to as the "double paper feed cabinet" throughout the manual.
9	Paper Feed Cabinet PC-403	Can be loaded with up to 2,500 sheets of paper Referred to as the "LCT" throughout the manual.
10	Finisher FS-514	Feeds out finished printed pages. The "Sort" setting (separating by copy set), "Group" setting (separating by page), and Staple settings (corner stapling and two-point stapling) are available.
11	Output Tray OT-601	Copy output tray installed onto the finisher FS-514 and used for separating printed pages Referred to as the "optional finishing tray" throughout the manual.
12	Punch Kit PK-510	Allows hole punching to be used if installed onto finisher FS-514
13	Mailbin Kit MT-501	Installed onto the finisher FS-514 to divide printed pages and feed them into the appropriate tray assigned to a specific individual or group (only with computer printing) Referred to as the "mailbin" throughout the manual.
14	Saddle Stitcher SD-503	Installed onto the finisher FS-514 to allow copies to be bound or folded at the center Referred to as the "saddle stitcher" throughout the manual.

No.	Part Name	Description
15	Finisher FS-603	Feeds out printed pages. The "Offset" setting (separating), Staple settings (stapling), and "Fold & Staple" function (binding) are available. <ul style="list-style-type: none"> In order to install the finisher, the main unit must be installed on the desk, on the LCT, on the single paper feed cabinet, or on the double paper feed cabinet.
16	Punch Kit PK-501	Allows hole punching to be used if installed onto finisher FS-603 Referred to as the "punch kit" throughout the manual.
17	Finisher FS-501	Finishes printed pages according to the selected Output setting (sorting or stapling), then feeds out the pages <ul style="list-style-type: none"> In order to install the finisher, the main unit must be installed on the desk, on the LCT, or on the single paper feed cabinet or the double paper feed cabinet.
18	Job Separator JS-601	Copy exit tray installed on finisher FS-501 Referred to as the "job separator" throughout the manual.
19	Main unit	The document is scanned by the scanner section, and the scanned image is printed by the printer section. Referred to as the "machine", the "main unit", or the "C252" throughout the manual.
20	Fax Kit FK-502*	Allows this machine to be used as a fax machine
21	Mount Kit MK-706*	Required to mount the fax kit and local interface kit
22	Mount Kit MK-704*	Installed when using this machine as a fax machine
23	Scan Accelerator Kit SA-501*	Creates images at high speed when sending scans, and allows scan jobs saved in boxes to be printed.
24	Local Interface Kit EK-702*	Used for making a local connection between this machine and the computer
25	Dehumidifer Heater 1C*	Installed in the paper feed cabinet or desk to prevent humidity from collecting in the paper
26	Security Kit SC-503*	Installed to encode the data saved on the hard disk so that the hard disk can be used more safely.

* Parts marked with an asterisk (*) are internal options and therefore are not shown in the illustration.



Reminder

In order to maintain the functionality and quality of the machine, be sure to use the desk or paper feed cabinet when installing the machine on the floor.

Either FS-501 or FS-603 can be installed on this machine as options. A kit is required in order to install FS-501 or FS-603. For details, contact your technical representative.

Outside of machine

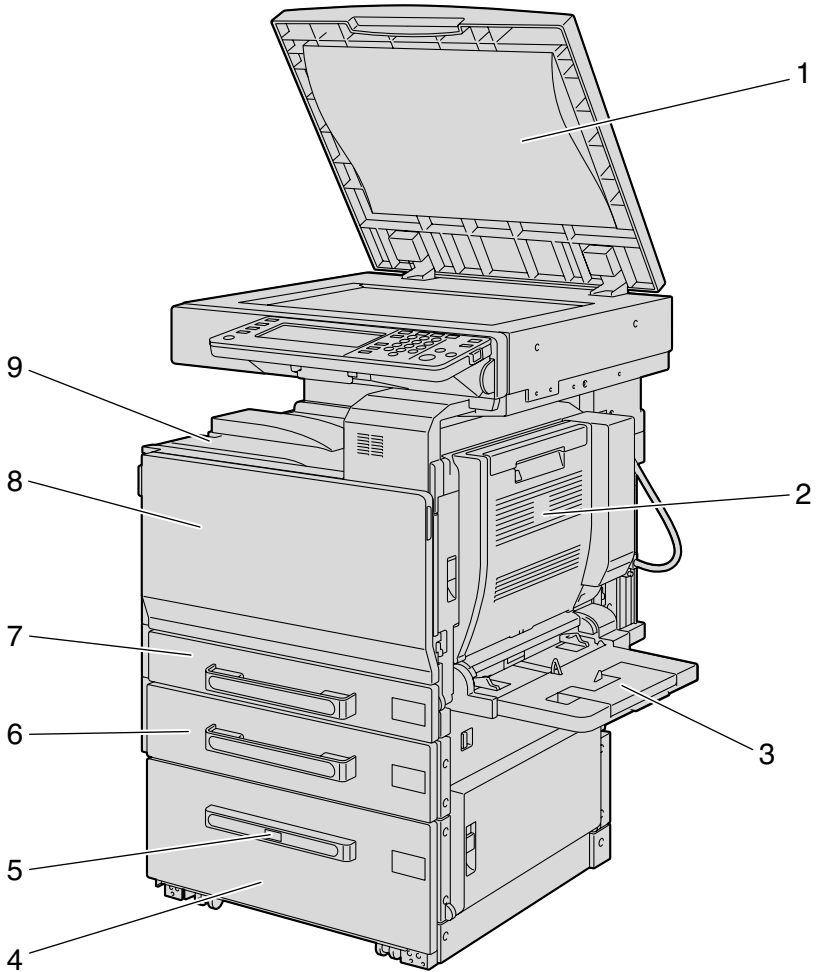

* The illustration above shows the main unit with the optional original cover, automatic duplex unit, and LCT installed.

No.	Part Name	Description
1	Original cover pad	Presses down on the loaded document to keep it in place
2	Automatic duplex unit	Turns over the paper for double-sided printing
3	Multiple bypass tray	Used when printing onto paper with a size not loaded into a paper tray or onto thick paper, overhead projector transparencies, postcards, envelopes or label sheets Holds up to 100 sheets of plain paper, 20 sheets of thick paper, overhead projector transparencies, postcards or label sheets, or 10 envelopes Referred to as the "bypass tray" throughout the manual. (See p. 2-58.)
4	LCT	Can be loaded with up to 2,500 sheets of plain paper
5	Tray release button	Pressed in order to pull out the paper tray for the LCT
6	2nd tray	Can be loaded with up to 500 sheets of plain paper (See p. 2-53.)
7	1st tray	Can be loaded with up to 250 sheets of plain paper, can be set to different paper sizes, and can be loaded with up to 20 sheets of thick paper, overhead projector transparencies, postcards, label sheets, or envelopes (See p. 2-47.)
8	Front door	Opened when replacing a toner cartridge or turning the main power switch on and off. (See p. 9-6.)
9	Copy exit tray	Collects printed pages

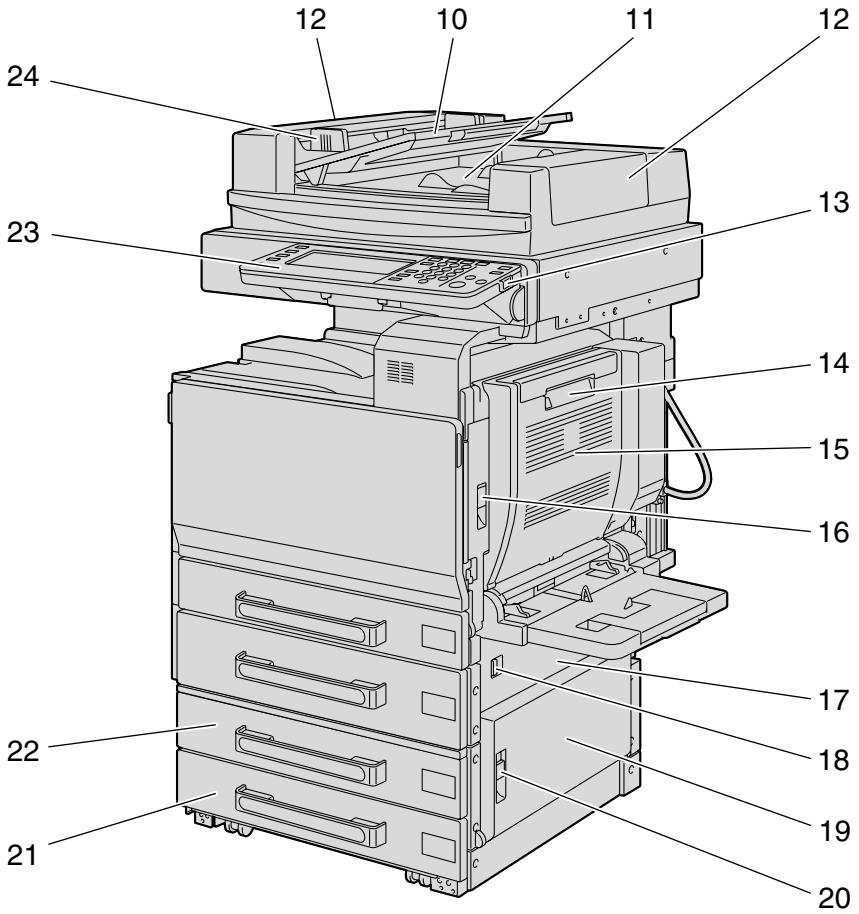

* The illustration above shows the main unit with the optional ADF, automatic duplex unit, and double paper feed cabinet installed.

No.	Part Name	Description
10	Document feed tray	Loaded with documents facing up (See p. 3-7.)
11	Document exit tray	Collects documents that have been scanned
12	Misfeed-clearing cover	Opened when clearing document misfeeds
13	[Power] (auxiliary power) key	Pressed to turn on/off machine operations, for example, for copying, printing or scanning When turned off, the machine enters a state where it conserves energy.
14	Automatic duplex unit release lever	Used to open the automatic duplex unit door when clearing paper misfeeds
15	Automatic duplex unit door	Opened when clearing paper misfeeds within the automatic duplex unit
16	Upper right-side door release lever	Used to open the upper right-side door
17	Center right-side door	Opened when clearing paper misfeeds from the 2nd tray
18	Center right-side door release lever	Used to open the center right-side door
19	Lower right-side door	Opened when clearing paper misfeeds from the 3rd or 4th trays or from the LCT
20	Lower right-side door release lever	Used to open the lower right-side door when clearing paper misfeeds
21	4th tray/storage tray	Used for storage when the single paper feed cabinet is installed Can be loaded with up to 500 sheets of plain paper when the double paper feed cabinet is installed (See p. 2-53.)
22	3rd tray	Can be loaded with up to 500 sheets of plain paper (See p. 2-53.)
23	Control panel	Used to specify the various settings (See p. 2-21.)
24	Adjustable document guide	Adjusted to the width of the document (See p. 3-7.)

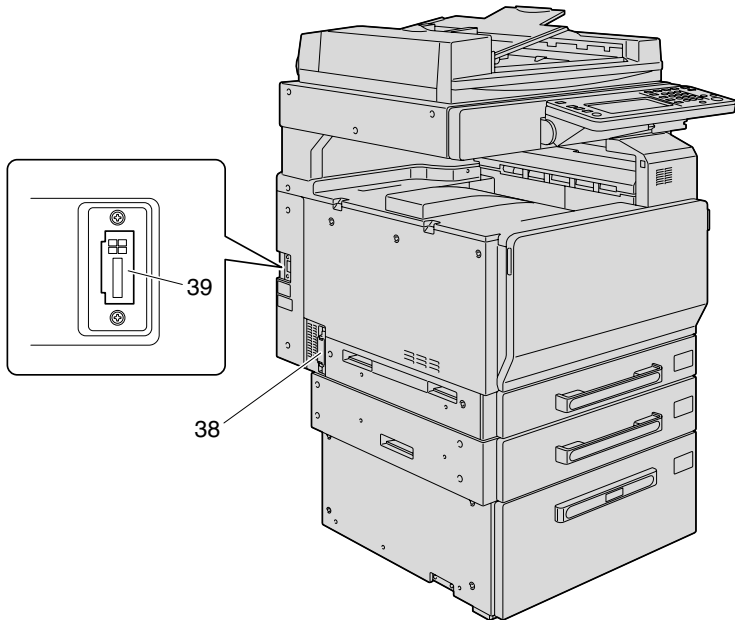
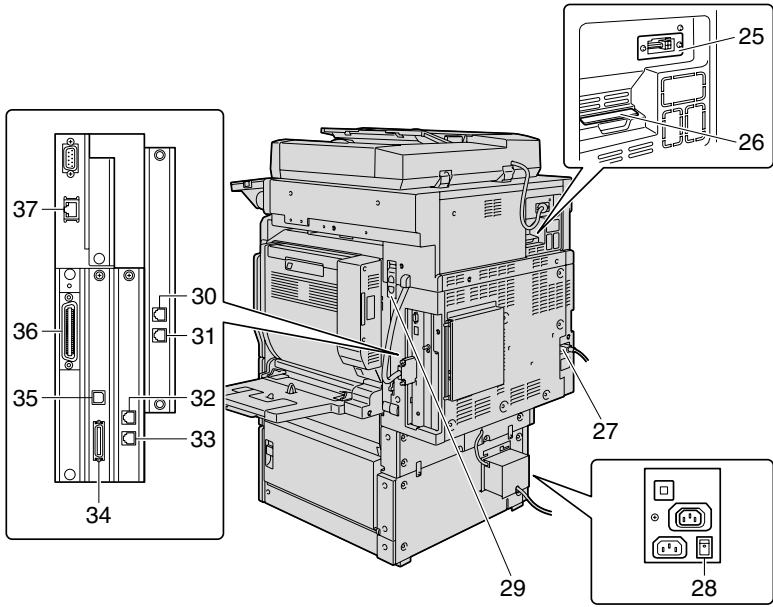

* The illustration above shows the main unit with the optional ADF, automatic duplex unit, LCT, fax multi line and dehumidifier heater installed.

No.	Part Name	Description
25	ADF connector	Used for connecting the ADF hookup cord
26	Filter 1	Collects the toner dust generated in the machine
27	Power connector	Used for connecting the power cord
28	Dehumidifier heater power switch	Used to turn the dehumidifier heater on and off. Turning on the dehumidifier heater reduces moisture in the paper. This switch is used when the optional dehumidifier heater is installed.
29	Filter 2	Collects the toner dust generated in the machine
30	TEL jack 2	Used for connecting a telephone
31	LINE jack 2	Used for connecting a general subscriber line. This jack is used when the optional fax multi line is installed.
32	TEL jack 1	Used for connecting a telephone
33	LINE jack 1	Used for connecting the general subscriber line
34	IEEE1284 port (type C)	Used for connecting the parallel cable from the computer
35	USB port (type B) USB 2.0/1.1-compliant	Used for connecting a USB cable from the computer
36	Internal controller port	Used for connecting the internal controller
37	Network connector (10 Base-T/100 Base -TX)	Used for connecting the network cable when this machine is used for network printing and network scanning
38	Ozone filter	Collects the ozone generated in the machine
39	Finisher connector	Used for connecting the finisher hookup cord

Inside of machine

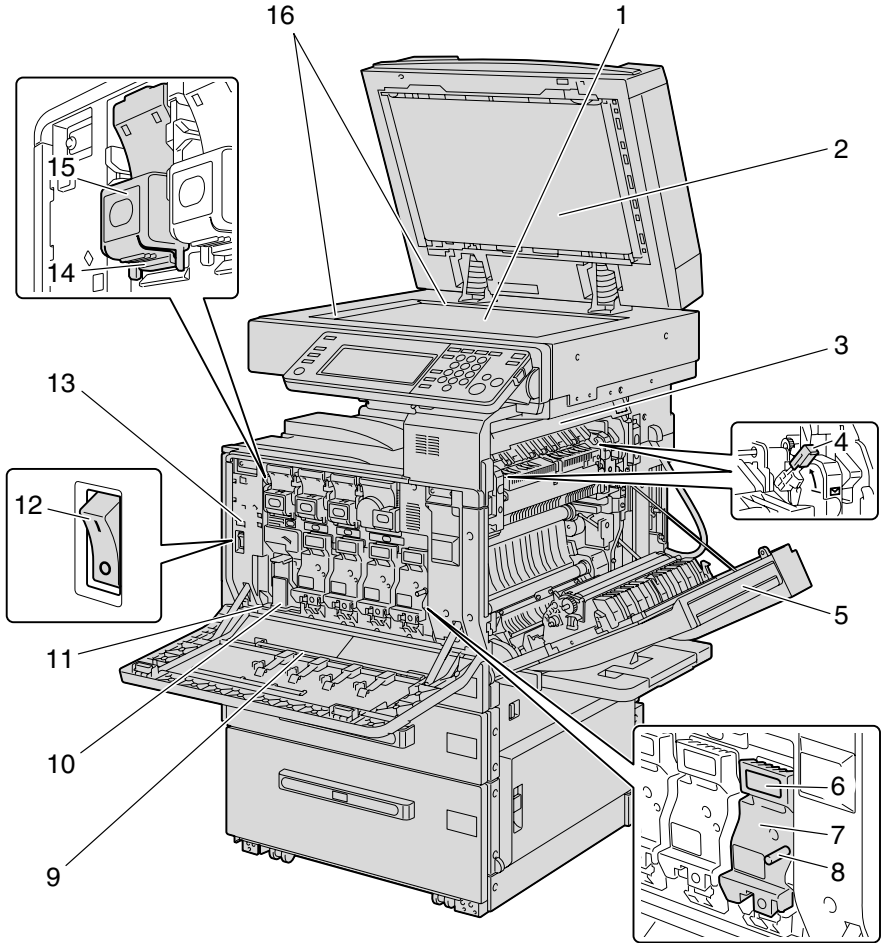

No.	Part Name	Description
1	Original glass	Place a document on the glass so that it can be scanned. (See p. 3-9.)
2	Document transfer belt	Feeds the document loaded into the ADF
3	Fusing unit cover	Opened when clearing paper misfeeds in the fusing unit
4	M2 release levers	Used when printing on envelopes. Used when clearing paper misfeeds in the fusing unit.
5	Main unit right-side door	Opened when clearing paper misfeeds from inside the main unit
6	Unlocking knob	Used when removing the imaging units
7	Imaging unit	Creates the print image
8	Charger-cleaning tool	Used to clean the electrostatic charger wire, for example, when incorrect copies are produced (See p. 10-6.)
9	Print head glass cleaning tool	Used to clean the surface of the print head glass, for example, when replacing the imaging unit
10	Waste toner box	Collects used waste toner
11	Waste toner box release lever	Used when removing the waste toner box
12	Main power switch	Used to turn the machine on and off (See p. 2-29)
13	Total counter	Shows the total number of pages that have been printed
14	Locking tab	Used when removing the toner cartridges
15	Toner cartridges	There are four toner cartridges: cyan (C), magenta (M), yellow (Y) and black (K). The combination of the four toners generates full-color images.
16	Document scales	Position the document so that it is aligned with the scales. Also, use the scales to measure the loaded document. (See p. 3-9.)

Saddle stitcher SD-503/mailbin kit MT-501

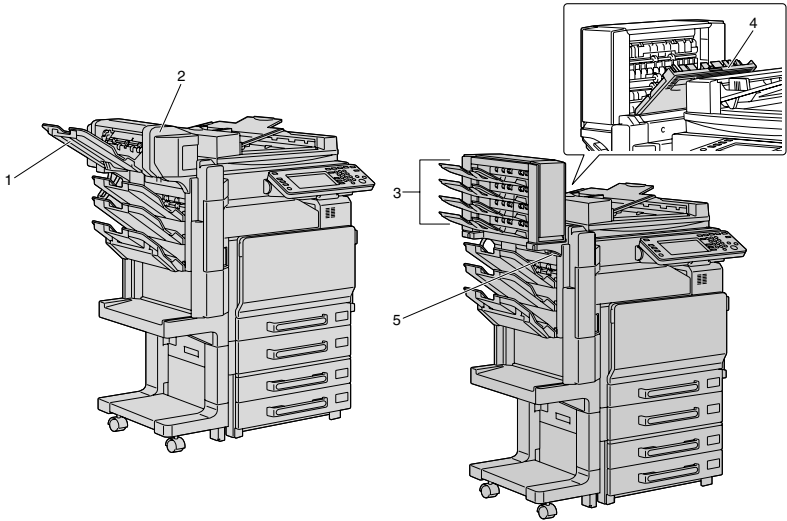

Saddle stitcher SD-503

No.	Part name	Description
1	Copy output tray	Collects copies
2	Misfeed-clearing door	Opened when clearing paper misfeeds within the finisher

Mailbin kit MT-501

No.	Part name	Description
3	Mailbins	Collects printed pages
4	Misfeed-clearing door	Opened when clearing paper misfeeds
5	Lever [FN7]	Opened when clearing paper misfeeds

Finisher FS-514/output tray OT-601/punch kit PK-510

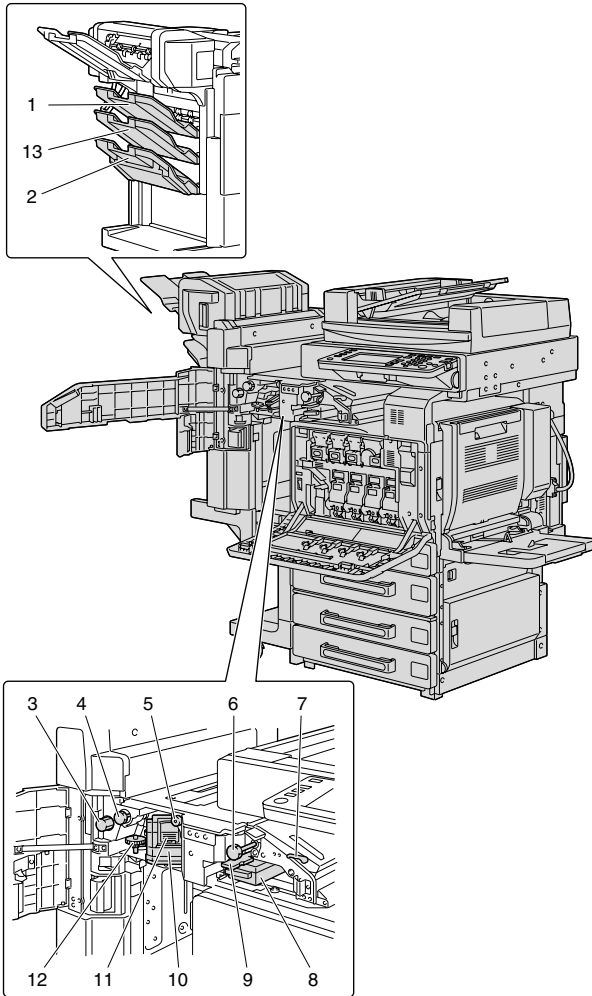

Finisher FS-514

No.	Part name	Description
1	Output tray 1	Collects copies that are fed out
2	Output tray 2	Collects copies that are fed out
3	Dial [FN6]	Turned when clearing paper misfeeds within the finisher
4	Dial [FN5]	Turned when clearing paper misfeeds within the finisher
5	Dial [FN4]	Turned when clearing paper misfeeds within the finisher
6	Dial [FN2]	Turned when clearing paper misfeeds within the finisher
7	Lever [FN1]	Raised when clearing paper misfeeds within the finisher
8	Hole-punch waste container	Removed when emptying hole-punch waste that has accumulated from using the punch settings
9	Lever [FN3]	Lowered when clearing paper misfeeds within the finisher
10	Stapler	Moved to the front when clearing jammed staples
11	Staple cartridge holder	Removed from the stapler when replacing the staple cartridge or clearing jammed staples
12	Dial	Turned to move the stapler to the front when clearing jammed staples

Output tray OT-601

No.	Part name	Description
13	Optional output tray	Collects copies

Punch kit PK-510

No.	Part name	Description
14	Punch Kit*	Punches holes for filing printed pages when punch kit PK-510 is installed onto finisher FS-514

Parts marked with an asterisk (*) are installed within the finisher and therefore are not shown in the illustration.

Finisher FS-603/punch kit PK-501

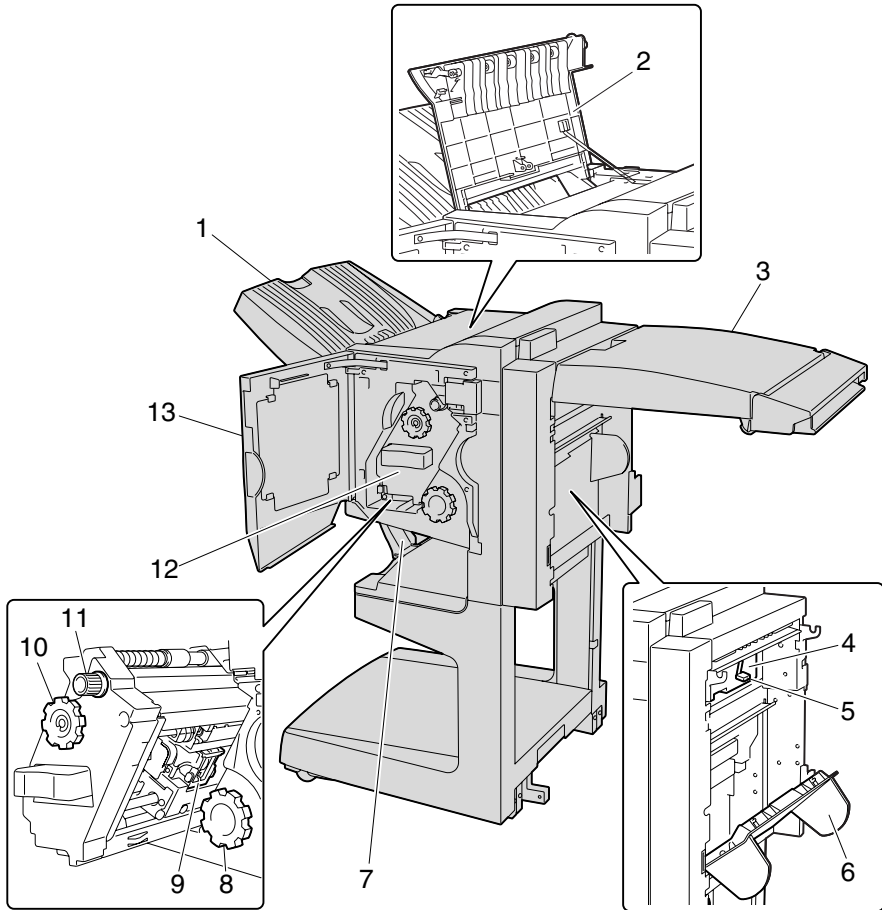

No.	Part Name	Description
1	Exit tray 1	Collects printed pages
2	Upper door	Opened when clearing paper misfeeds (See p. 5-45.)
3	Horizontal transport unit cover	Opened when clearing paper misfeeds from the horizontal transport unit (See p. 5-45.)
4	Hole-punch waste container	Removed when emptying hole-punch waste that has accumulated from using the Punch settings (See p. 9-46.)
5	Misfeed-clearing guide	Opened when clearing paper misfeeds within the finisher (See p. 5-45.)
6	Right-side door	Opened when clearing paper misfeeds within the finisher (See p. 5-45.)
7	Exit tray 2	Collects copies printed using the "Fold & Staple" setting
8	Misfeed-clearing dial in folding section	Turned when clearing paper misfeeds in the folding section (See p. 5-45.)
9	Staple cartridge holder	Removed from the stapler unit when clearing jammed staples or replacing the staple cartridge (See p. 9-19, p. 9-37.)
10	Misfeed-clearing dial 1	Turned when clearing paper misfeeds within the finisher (See p. 5-45.)
11	Misfeed-clearing dial 2	Turned when clearing jammed staples or replacing the staple cartridge, or for moving the staple cartridge holder out to the front (See p. 9-37.)
12	Stapler unit	Pulled out when clearing jammed staples or replacing the staple cartridge (See p. 9-19, p. 9-37.)
13	Front door	Opened when clearing paper misfeeds or jammed staples or when replacing the staple cartridge (See p. 9-19, p. 9-37.)
14	Punch kit*	Punches holes for filing printed pages when punch kit PK-501 is installed onto finisher FS-603

* Parts marked with an asterisk (*) are installed within the finisher and therefore are not shown in the illustration.

Finisher FS-501/job separator JS-601

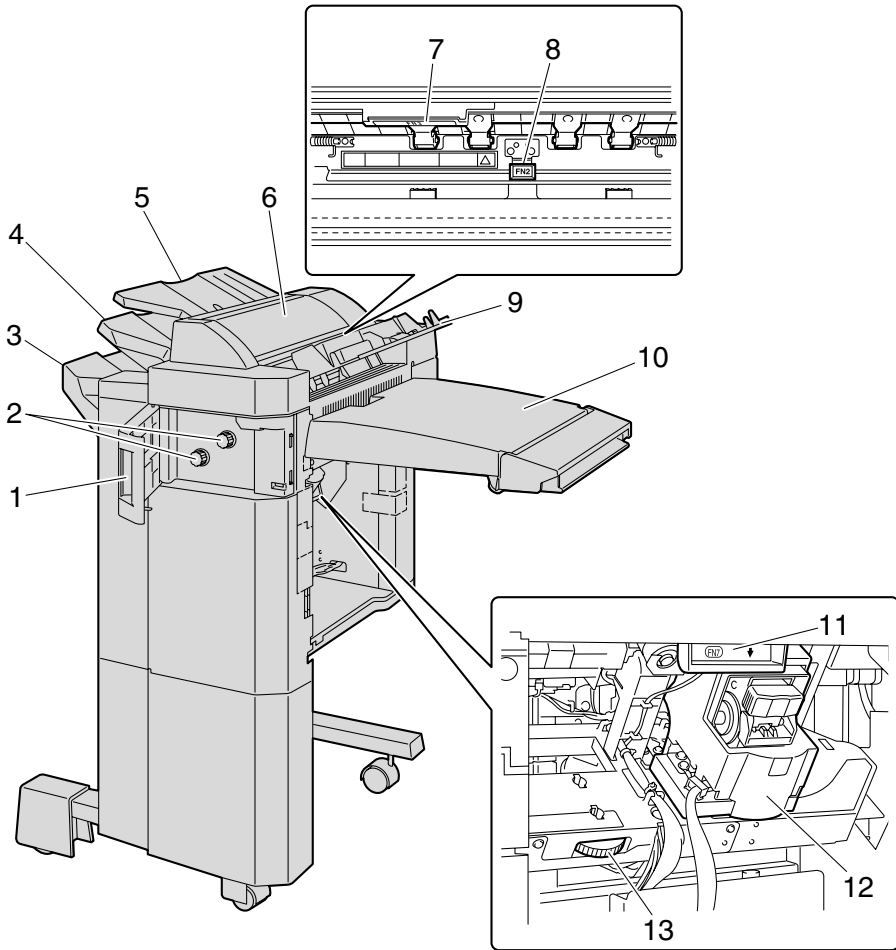

No.	Part Name	Description
1	Front door FN4	Opened when clearing paper misfeeds within the finisher (See p. 5-40.)
2	Misfeed-clearing dials FN5	Turned when clearing paper misfeeds within the finisher (See p. 5-40.)
3	Exit tray 2	Collects printed pages
4	Exit tray 1	Collects printed pages
5	Exit tray 3	Feeds out printed pages when job separator JS-601 is installed onto finisher FS-501
6	Job separator cover	Opened when clearing paper misfeeds within the job separator (See p. 5-40.)
7	Misfeed-clearing guide FN3	Opened when clearing paper misfeeds within the finisher (See p. 5-40.)
8	Misfeed-clearing guide FN2	Opened when clearing paper misfeeds within the finisher (See p. 5-40.)
9	Upper cover FN1	Opened when clearing paper misfeeds within the finisher (See p. 5-40.)
10	Horizontal transport unit cover	Opened when clearing paper misfeeds from the horizontal transport unit (See p. 5-40.)
11	Misfeed-clearing guide FN7	Opened when clearing paper misfeeds within the finisher (See p. 5-40.)
12	Stapler	Used to staple pages
13	Jammed-staple-clearing dial	Turned when clearing jammed staples or replacing the staple cartridge, or for moving the stapler to the center (See p. 9-16, p. 9-35.)

Precautions for using the finisher:

- When moving the finisher, do not grab the exit tray.

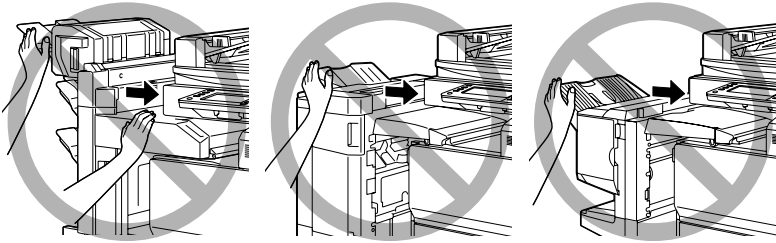

- Do not place objects on top of the saddle stitcher or mailbin kit.
- Do not place objects below the output trays of the finisher.

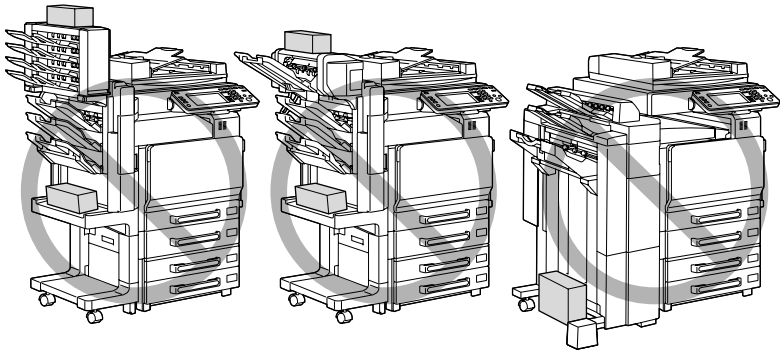

Control panel

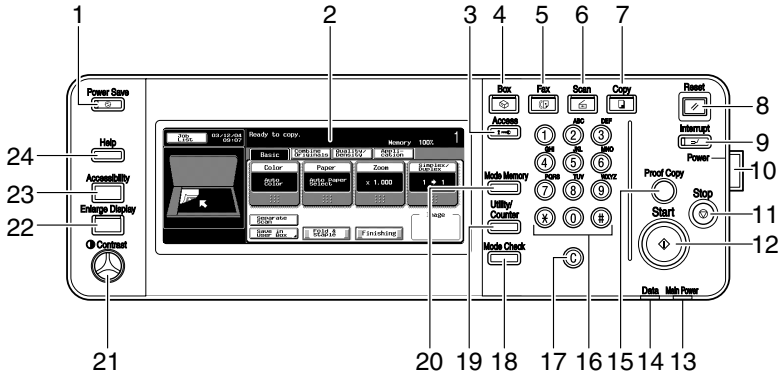

No.	Part Name	Description
1	[Power Save] key	Press to enter Low Power mode. While the machine is in Low Power mode, the indicator on the [Power Save] key lights up in green and the touch panel goes off. To cancel Low Power mode, press the [Power Save] key again.
2	Touch panel	Displays various screens and messages. Specify the various settings by directly touching the panel.
3	[Access] key	If user authentication or account track settings have been applied, press this key after entering the user name and password (for user authentication) or the account name and password (for account track) in order to use this machine.
4	[Box] key	Press to enter Box mode. While the machine is in Box mode, the indicator on the [Box] key lights up in green. For details, refer to the Box Operations of the User's Guide.
5	[Fax] key	Press to enter Fax mode. While the machine is in Fax mode, the indicator on the [Fax] key lights up in green. For details, refer to the Facsimile Operations and the Network Facsimile Operations of the User's Guide.
6	[Scan] key	Press to enter Scan mode. While the machine is in Scan mode, the indicator on the [Scan] key lights up in green. For details, refer to the Network Scanner Operations of the User's Guide.

No.	Part Name	Description
7	[Copy] key	Press to enter Copy mode. (As a default, the machine is in Copy mode.) While the machine is in Copy mode, the indicator on the [Copy] key lights up in green.
8	[Reset] key	Press to clear all settings (except programmed settings) entered in the control panel and touch panel.
9	[Interrupt] key	Press to enter Interrupt mode. While the machine is in Interrupt mode, the indicator on the [Interrupt] key lights up in green and the message "Now in Interrupt mode." appears on the touch panel. To cancel Interrupt mode, press the [Interrupt] key again.
10	[Power] (auxiliary power) key	Press to turn on/off machine operations, for example, for copying, printing or scanning. When turned off, the machine enters a state where it conserves energy.
11	[Stop] key	Press the [Stop] key during copying to stop the copy operation.
12	[Start] key	Press to start copying. When this machine is ready to begin copying, the indicator on the [Start] key lights up in green. If the indicator on the [Start] key lights up in orange, copying cannot begin. Press to restart a stopped job. For details on jobs, refer to "Managing jobs (Job List)" on page 11-2.
13	Main Power indicator	Lights up in green when the machine is turned on with the main power switch
14	Data indicator	Flashes in green while a print job is being received Lights up in green while a print job is queued to be printed or while it is printing
15	[Proof Copy] key	Press to print a single sample copy to be checked before printing a large number of copies. (See p. 4-5.)
16	Keypad	Use to type in the number of copies to be produced. Use to type in the zoom ratio. Use to type in the various settings.
17	[C] (clear) key	Press to erase a value (such as the number of copies, a zoom ratio, or a size) entered using the keypad.
18	[Mode Check] key	Press to display screens showing the specified settings.
19	[Utility/Counter] key	Press to display the Meter Count screen and the Utility screen.
20	[Mode Memory] key	Press to register the desired copy settings as a program or to recall a registered copy program. (See p. 4-14.)
21	Contrast dial	Use to adjust the contrast of the touch panel.
22	[Enlarge Display] key	Press to enter Enlarge Display mode.

No.	Part Name	Description
23	[Accessibility] key	Press to display the screen for specifying user accessibility functions.
24	[Help] key	Press to display the Main Help Menu screen, where descriptions of the various functions and details of operations can be displayed. (See p. 4-17.)

**Reminder**

Do not apply extreme pressure to the touch panel, otherwise it may be scratched or damaged.

Never push down on the touch panel with force, and never use a hard or pointed object to make a selection in the touch panel.

Basic settings screen (Basic screen)

When the machine is ready to begin making copies after being turned on, the Basic screen appears.

To activate a function or to select a setting, lightly touch the desired button in the touch panel.

TYPE 1

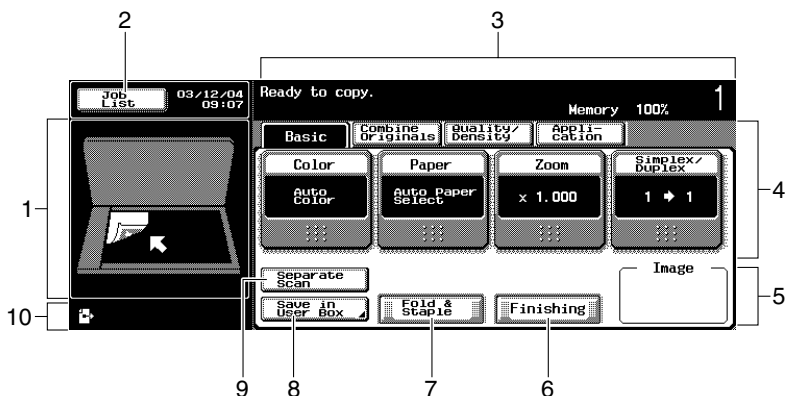

TYPE 2

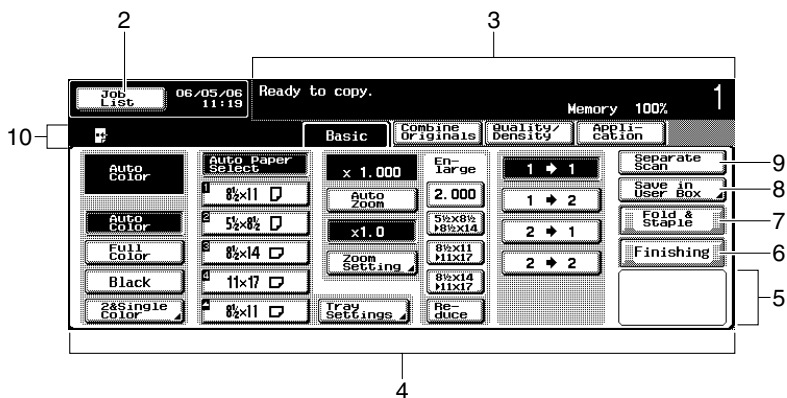

No.	Item Name	Description
1	Sub display area	The results of operations and settings are displayed.

No.	Item Name	Description
2	[Job List] button	Jobs currently being performed or waiting to be performed are displayed. Various commands for checking and managing jobs are available. (See p. 11-2.)
3	Message display area	The status of the machine and details on operations that must be performed are displayed here.
4	Functions/settings display	Tabs and buttons for displaying screens containing various functions are displayed. Touch a tab or button to display the corresponding screen for specifying the settings.
5	Image display	An image of the specified settings, such as stapling and hole punching, are displayed.
6	[Finishing] button	Touch to specify settings for collating, uncollating, stapling, or hole punching. (See p. 3-67.)
7	[Fold & Staple] button	Touch to specify the function for folding and binding pages.
8	[Save in User Box] button	Touch to save the data of scanned image in a box. Various commands are available to specify the box where the data is to be saved and whether or not the data is printed when it is saved. For details, refer to the Box Operations of the User's Guide.
9	[Separate Scan] button	Touch to scan the document in separate batches. A document scanned in different batches can be treated as a single copy job. (See p. 3-11.)
10	Icon display area	Icons indicating the status of jobs and the machine are displayed.









Detail

The Basic screen (TYPE1 or TYPE2) that appears can be set with the "Copy Initial Screen Setting" parameter in the Display Setting screen (displayed from the User Setting screen). The arrangement of the buttons and screens differ with TYPE1 and TYPE2; however, the functions that can be set are the same. As a default, "TYPE1" is selected. This manual contains descriptions of procedures using the Basic screen that appears when "TYPE1" is selected.

For details on switching between the two types of Basic screens, refer to "Display setting" on page 12-19.

If settings have been changed from the factory defaults, the tab for the screen containing the changed settings appears framed with a solid line.

Icons that appear in the screen

Icon	Description
	Indicates that data is being sent from the machine, regardless of the current mode
	Indicates that this machine is receiving data, regardless of the current mode
	Indicates that an error occurred during an image stabilization operation, a print operation or a scan operation Touch this icon to view a screen containing a warning code.
	If the warning screen was closed when a warning occurred, touch this button to display the warning screen again.
	Indicates that paper is not loaded in the paper tray
	Indicates that not much paper remains in the paper tray
	Indicates that "Enhanced Security Mode" is set to "ON"

2.2 Adjusting the angle of the control panel

The control panel can be adjusted to any of three angles.

Adjust the control panel to the angle that allows for easy operation.

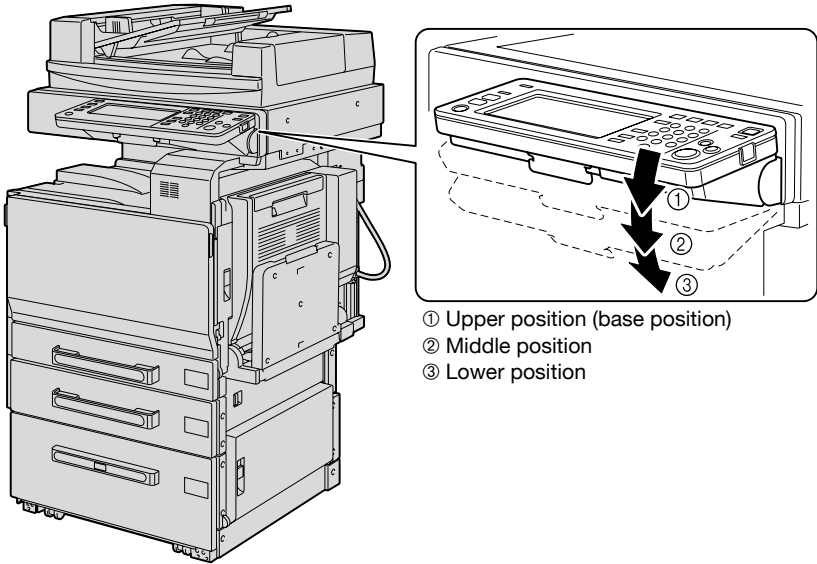

To adjust the angle of the control panel

- 1 Pull the control panel release lever toward you, and then push down on the control panel.

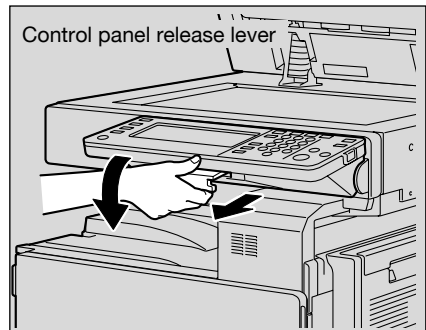

The control panel stops at the middle position.

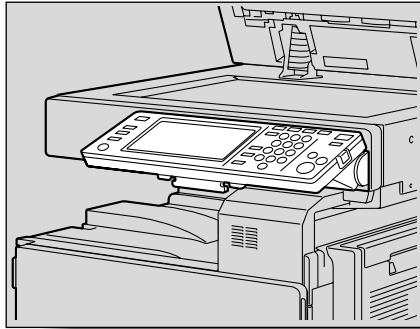

- 2 To adjust the control panel to an even steeper angle, pull the control panel release lever toward you, and then push down on the control panel.

The control panel stops at the lower position.

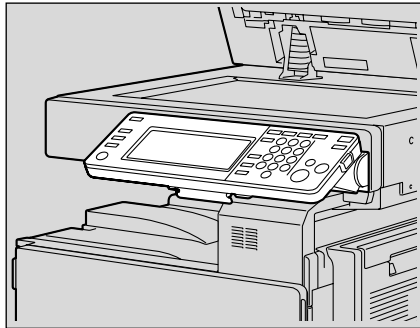

- 3 To return the control panel to the upper position, pull the control panel release lever toward you, and then pull up on the control panel.

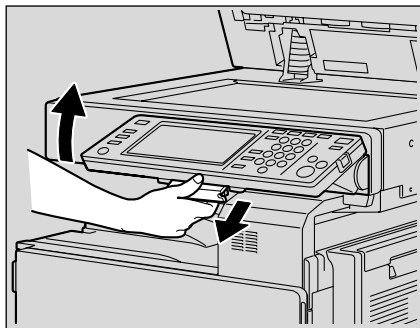

2.3 Turning on the Main Power and the Auxiliary Power

This machine has two power controls: the main power switch and the [Power] (auxiliary power) key.

To turn on the machine

The main power switch turns on/off all functions of the machine. Normally, the main power switch is turned on.

The [Power] (auxiliary power) key turns on/off machine operations, for example, for copying, printing or scanning. When the [Power] (auxiliary power) key is turned off, the machine enters a state where it conserves energy.

- 1 Open the machine's front door, and then set the main power switch to [I].

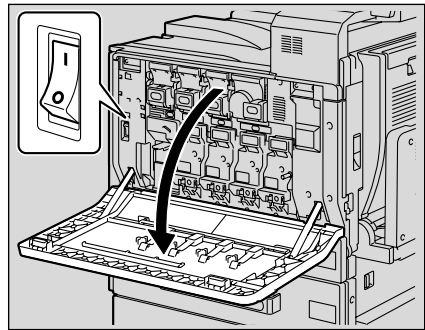

- 2 Close the front door.
- 3 Press the [Power] (auxiliary power) button.
Check that the touch panel is turned on.

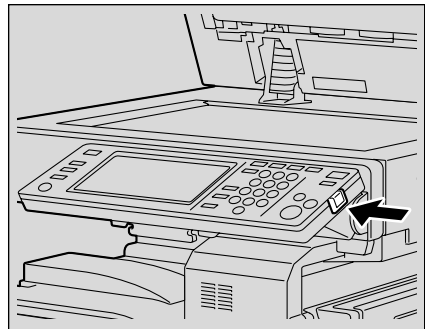

**Detail**

When the control panel is turned on by pressing the [Power] (auxiliary power) button, the indicator on the [Start] key lights up in orange, and a screen indicating that the machine is starting up appears.

After a few seconds, the message "Now warming up. Ready to scan." appears on the touch panel, and the indicator on the [Start] key lights up in green, indicating that a job can now be queued.

The default settings are those that are selected immediately after the machine is turned on (the power switch is set to "I") and before any setting is specified from the control panel or touch panel, and those that are selected when the [Reset] key is pressed to cancel all settings specified from the control panel or touch panel. The default settings can be changed. For details, refer to "Initial setting" on page 12-21.

The factory default settings are the settings that were selected when this machine was sent from the factory.

**Note**

A job can also be queued while the machine is warming up after the [Power] (auxiliary power) key is pressed. For details, refer to "To scan during warm-up" on page 2-31.

After the machine has finished warming up, the scanned image will be printed.

The machine takes about 110 seconds to warm up at normal room temperature (73.4°F) when the control panel is turned on using the [Power] (auxiliary power) key after the machine is turned on using the main power switch.

To scan during warm-up

- 1 Press the [Power] (auxiliary power) button.
The indicator on the [Start] key lights up in orange.
? How is the machine turned on?
→ For details on turning on the machine, refer to “To turn on the machine” on page 2-29.
- 2 Check that the message “Now warming up. Ready to scan.” appears on the touch panel.

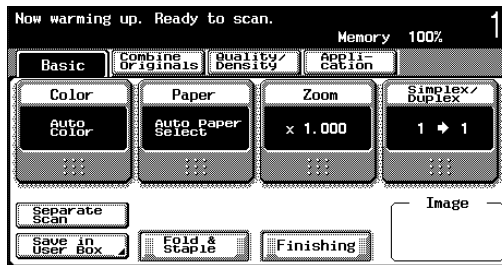

- After the warm-up message is displayed, the Basic screen appears. The indicator on the [Start] key lights up in green.
- 3 Position the document to be copied.
? How is the document positioned?
→ For details on positioning the document to be copied, refer to “Feeding the document” on page 3-7.
 - 4 Specify any necessary copy settings.
 - 5 Using the keypad, specify the desired number of copies.
? How is the number of copies specified?
→ For details on specifying the number of copies, refer to “General copy operation” on page 3-2.
 - 6 Press the [Start] key.
The document is scanned, and the job is added to the list of queued jobs.
 - 7 Check that the document has finished being scanned, and then position the next document.

- 8 Specify new copy settings and the desired number of copies, and then press the [Start] key.
- After the machine has finished warming up, the jobs will automatically be printed in the order that they were queued.
- ? How is the printing of a job stopped?
- Press the [Stop] key. For details, refer to “Stopping scanning/printing” on page 3-86.

**Detail**

While the machine is warming up to begin printing after it is turned on using the [Power] (auxiliary power) key, copy settings can be specified and a document can be scanned to reserve a copy job. After the machine has finished warming up, the copies are automatically printed.

The print order can be changed or jobs can be deleted from the Current Jobs list of the Job List screen. For details, refer to “Managing jobs (Job List)” on page 11-2.

To turn off the machine

- 1 Press the [Power] (auxiliary power) button.
 - Check that the touch panel is turned off.
- 2 Open the machine's front door.
- 3 Set the main power switch to [O].

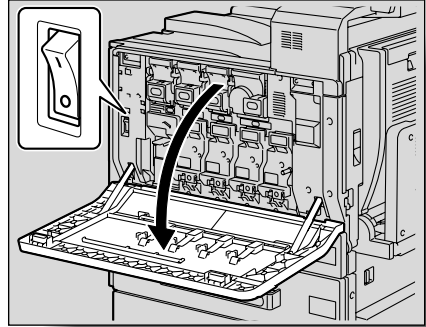

- 4 Close the front door.

**Reminder**

When the main power switch is turned off, then on again, wait at least 10 seconds to turn it on after turning it off. If there is no wait period between turning the main power switch off, then on again, the machine may not function properly.

Do not turn off the machine with the main power switch or the [Power] (auxiliary power) key while it is making copies or printing, otherwise a paper misfeed may occur.

Do not turn off the machine with the main power switch or the [Power] (auxiliary power) key while it is scanning or sending or receiving data, otherwise all scanned data or transmission data will be deleted.

Do not turn off the machine with the main power switch while a queued job or stored data is waiting to be printed, otherwise the jobs will be deleted.

**Detail**

The following are cleared when the main power switch and [Power] (auxiliary power) key are turned off.

Settings that have not been programmed

Jobs queued to be printed

Automatically canceling the settings (automatic panel reset)

If the [Reset] key is not pressed and no operation is performed for a specified length of time, settings that have not been programmed, such as the number of copies, are cleared and return to their default settings.

This is the automatic panel reset operation.

As the factory default, the automatic panel reset operation is performed after 1 minute.

**Detail**

The length of time until the automatic panel reset operation is performed and whether or not it is performed can be set from the Utility mode. For details, refer to "System setting" on page 12-27.

Whether or not the automatic panel reset operation is performed when there is a change of user can be set from the Utility mode. For details, refer to "System setting" on page 12-27.

Automatically canceling the mode screen (automatic system reset)

If no operation is performed for a specified length of time, the screen is automatically changed to that for the mode given priority.

This is the automatic system reset operation.

As the factory default, the Copy mode screen is displayed after 1 minute.

**Detail**

The mode screen that is displayed when the automatic system reset operation is performed can be changed from the Utility mode. For details, refer to "System setting" on page 12-27.

Automatically conserving energy (Low Power mode)

If no operation is performed for a specified length of time, the touch panel goes off and the machine automatically enters a mode where it conserves energy.

This is the Low Power mode.

The machine can receive jobs even while it is in Low Power mode.

As the factory default, the machine enters Low Power mode after 15 minutes.

To recover from Low Power mode

- 1 Press the [Power Save] key.
- 2 The machine can receive jobs while it is warming up.
 - The touch panel comes on again and, after the machine has finished warming up, it is ready to begin printing (within 30 seconds at normal room temperature (73.4°F)).



Note

As the factory default, pressing the [Power Save] key causes the machine to enter Low Power mode. Settings in the Administrator mode can be changed to put the machine in Sleep mode instead. For details, refer to “System setting” on page 12-27.

The Low Power mode can also be canceled by pressing any key in the control panel or by touching the touch panel.



Detail

The length of time until the machine enters Low Power mode can be changed. For details, refer to “System setting” on page 12-17, page 12-27.

Automatically conserving energy (Sleep mode)

If no operation is performed for a specified length of time, the machine automatically enters a mode where it conserves energy.

Although the machine conserves more energy in Sleep mode than in Low Power mode, the machine must warm up when Sleep mode is canceled to begin printing again, therefore taking more preparation time than Low Power mode.

As the factory default, the machine enters Sleep mode after 30 minutes.

To recover from Sleep mode

- 1 Press the [Power Save] key.
- 2 The machine can receive jobs while it is warming up.
 - The touch panel comes on again and, after the machine has finished warming up, it is ready to begin printing (within 110 seconds at normal room temperature (73.4°F)).



Note

The Sleep mode can also be canceled by pressing any key in the control panel or by touching the touch panel.



Detail

As the factory default, the machine enters Low Power mode if no operation is performed for 15 minutes, and then the machine enters Sleep mode after 30 minutes have elapsed.

The length of time until the machine enters Sleep mode can be changed. For details, refer to "System setting" on page 12-17, page 12-27.

Manually conserving energy

The machine can be manually set to an energy conservation mode.

- Press the [Power Save] key (or press the [Power] (auxiliary power) button).
 - As the factory default, the machine enters Low Power mode.

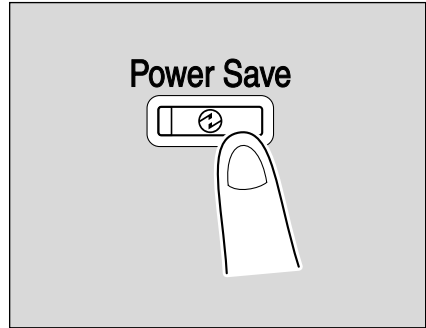

Detail

Whether the machine enters Low Power mode or Sleep mode when the [Power Save] key is pressed can be set from the Administrator mode. For details, refer to "System setting" on page 12-27.

Automatically turning the machine on/off (weekly timer)

The machine can be set to automatically enter Sleep mode according to a usage schedule determined by the administrator or limitations on the use of the machine can be specified.

This is the weekly timer.

Follow the procedure described below to use the machine while the weekly timer is being used.

- 1 Press the [Power Save] key.
 - ? How is the weekly timer set?
 - For details on setting the weekly timer, refer to “System setting” on page 12-27.

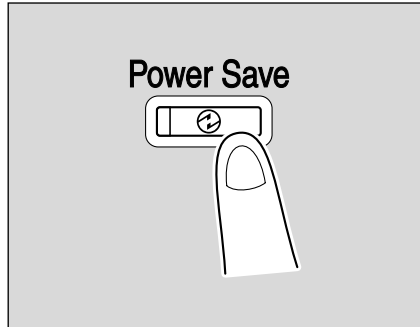

- 2 Type in the password (up to 8 digits) for non-business hours.

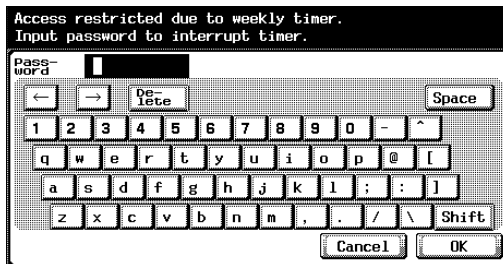

- ? How is the password for non-business hours specified?
 - For details on specifying the password for non-business hours, refer to “System setting” on page 12-27.
- 3 Touch [OK].

The message “Access restricted due to weekly timer. Input amount of time prior to entering Sleep Mode.” appears on the touch panel.

- 4 Using the keypad, type in the length of time until the machine enters Sleep mode again.

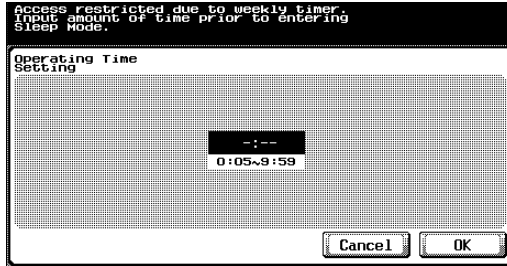

Specify a length of time between 5 minutes and 9 hours and 59 minutes.

? How can a single digit be input?

→ First, type in “0”. If a minutes setting of less than 5 is entered, the setting changes to 5 minutes. In addition, a minutes setting of 60 or more cannot be specified.

- 5 Touch [OK].

The message “Ready to copy.” appears on the touch panel.



Note

As the factory default, the weekly timer is not set.

If the message “Access restricted due to weekly timer. Input amount of time prior to entering Sleep Mode.” or “Access restricted due to weekly timer. Input password to interrupt timer.” appears after the [Power] (auxiliary power) key is pressed, the weekly timer is set.



Detail

During the set time, the copy operations can be performed as usual.

From the Password for Non-Business Hours screen (displayed from Administrator mode), the machine can be set so that the screen for entering the password for non-business hours is not displayed.

The default setting for the “Password for Non-Business Hours” parameter is “OFF” (the screen is not displayed).

Controlling each user's use of this machine (user authentication)

If user authentication settings have been specified by the administrator, only users that have been registered can use this machine.

- ✓ When user authentication has been set, only users that enter passwords for specified accounts can use this machine.
- ✓ Contact your administrator for account passwords.
- ✓ A total of 1000 users and accounts can be registered.

1 Touch [User Name].

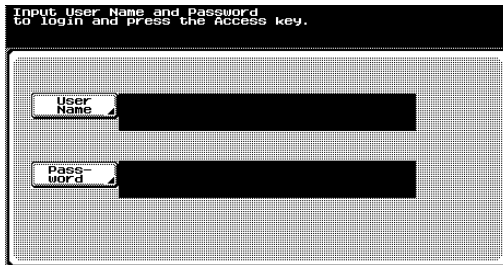

- If "Enhanced Security Mode" is set to "ON", [Public User Access] and [List] do not appear.



- If “Active Directory” was selected for external server authentication, [Domain Name] appears with the name of the default server. Touch [Domain Name] to display the names of servers registered with “Active Directory”, and then select the desired server. For details on specifying settings for an external server, refer to “To select an authentication method” on page 12-81.



- 2 Type in the user name, and then touch [OK].

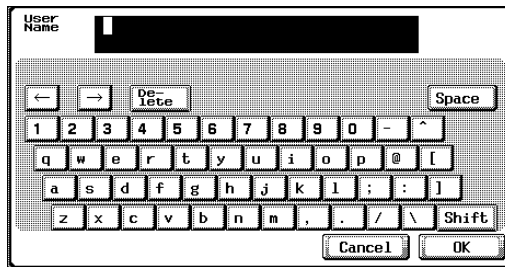

- 3 Touch [Password].



- 4 Type in the password, and then touch [OK].

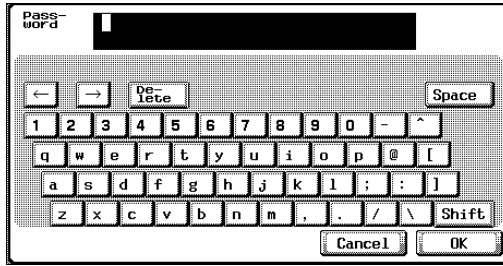

- 5 Press the [Access] key.
The Basic screen appears.

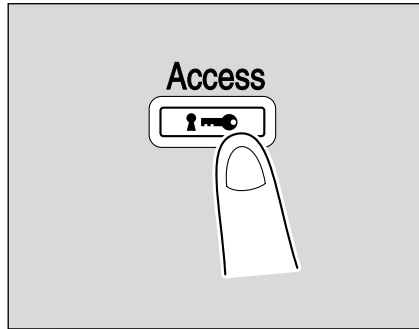

- 6 Make copies using the desired copy settings.
7 When you are finished printing, press the [Access] key.
A message appears, requesting confirmation to log off.

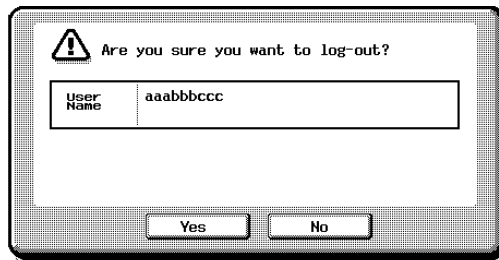

- 8 Touch [Yes].
The user authentication screen appears again.

**Detail**

For details on specifying user authentication settings, refer to “User authentication/account track” on page 12-38.

**Note**

The user authentication settings can be used together with the account track settings. If the “Synchronize User Authentication & Account Track” parameter is set to “Synchronize”, complete user authentication, and then log on by using the account track input screen.

User authentication settings can be specified using the User Authentication Setting parameters in Administrator mode, available from the Utility mode. Settings should be specified by the administrator.

If a list of user names can be displayed, the desired user name can be selected from the list. Touch [List], touch the button for the desired user name to select it, and then touch [OK].

Users who have no access to a user name and password can touch [Public User Access] to use this machine. For details on specifying public user settings, refer to “To select an authentication method” on page 12-81 and “Authenticating public users” on page 12-88.

If account track settings have been applied, the account track screen appears. However, if “Synchronize User Authentication & Account Track” has been set to “Synchronize”, the account track screen does not appear if the users and accounts are synchronized.

Controlling each account’s use of this machine (account track)

If account track has been set by the administrator, only users of registered accounts can use this machine. In addition, the number of prints produced with each account can be controlled.

This is account track.

- ✓ When account track has been set, only users that enter passwords for specified accounts can use this machine.
- ✓ Contact your administrator for account passwords.
- ✓ A total of 1000 users and accounts can be registered.

- 1 Touch [Account Name].



- If the Administrator mode settings have been set to "Password Only", touch [Input], and then continue with step 4.

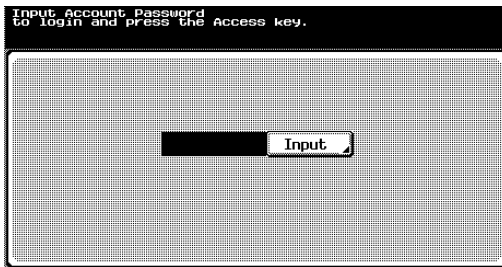

- 2 Type in the account name, and then touch [OK].

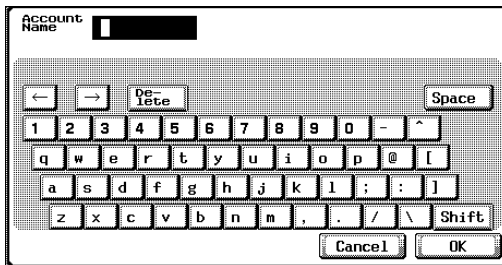

- 3 Touch [Password].

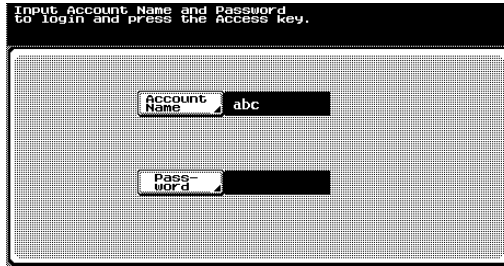

- 4 Type in the password, and then touch [OK].

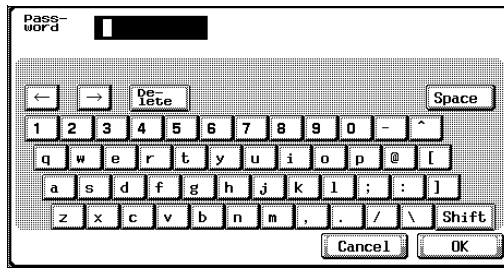

- 5 Press the [Access] key.

The Basic screen appears.

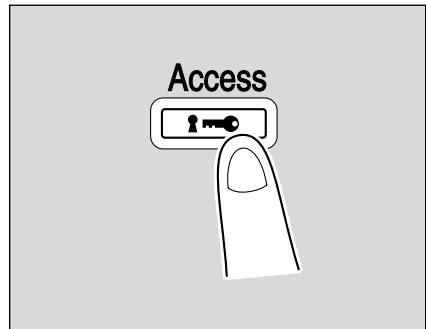

- 6 Make copies using the desired copy settings.

- 7 When you are finished printing, press the [Access] key.
A message appears, requesting confirmation to log off.

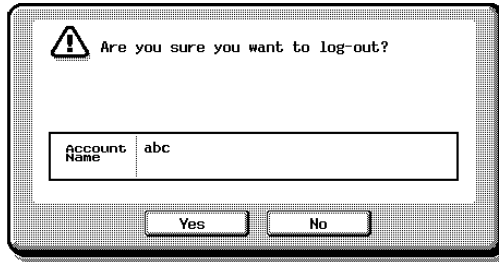

- 8 Touch [Yes].
The account track screen appears again.



Detail

If “Account Track Input Method” on the General Settings screen of Administrator mode was set to “Password Only”, log on is possible by only entering the password. For details, refer to “User authentication/account track” on page 12-38.

The accounts can be managed using the User Authentication Setting and Account Track Setting functions in Administrator mode, available from the Utility mode. Settings should be specified by the administrator.

For details on specifying account track settings, refer to “User authentication/account track” on page 12-38.

2.4 Loading paper into the 1st tray

To load paper (1st tray)

- 1 Pull out the 1st tray.
- 2 Press down on the paper-lifting plate until it locks into place.

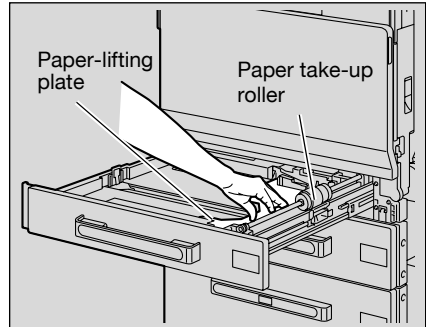

- 3 Slide the lateral guides to fit the size of paper to be loaded.

- ? How is non-standard sized paper loaded?
- First load the paper, and then adjust the lateral guides to the size of the loaded paper.

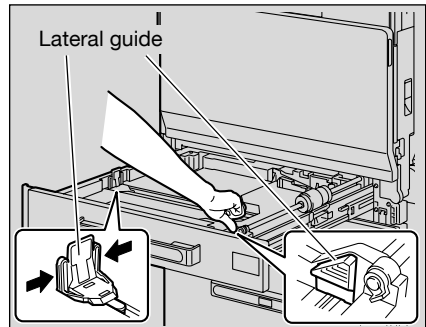

- 4 For paper exceeding 11 × 17 size, adjust the trailing-edge guides as shown in the illustration.

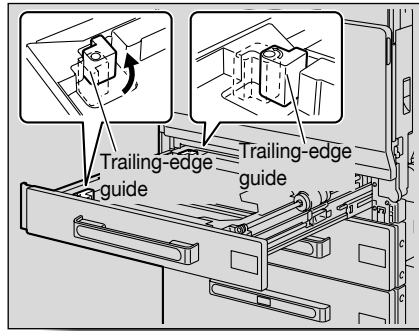

- 5 Load the paper into the tray so that the side of the paper to be printed on (the side facing up when the package was unwrapped) faces up.

- Load letterhead paper so that the side to be printed on faces down.

? How is curled paper loaded?

- Flatten the paper before loading it.

? How many sheets of paper and other media can be loaded?

- No more than 250 sheets of plain paper can be loaded. No more than 20 sheets of thick paper, overhead projector transparencies, postcards, label sheets or envelopes can be loaded.
- Do not load so many sheets of plain paper that the top of the stack is higher than the ▼ mark.

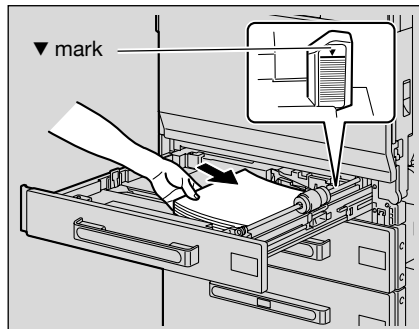

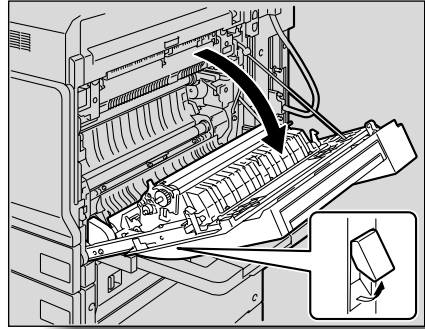

- 6 Close the 1st tray.
- If envelopes are loaded, continue with step 7.

- 7 Pull up the upper right-side door release lever, and then open the upper right-side door.

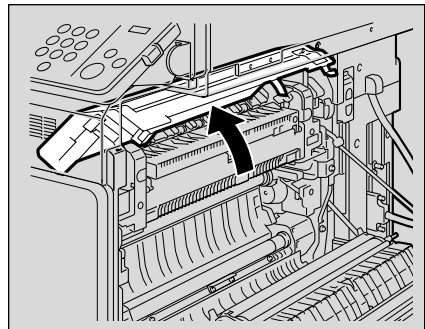

- 8 Push up the fusing unit cover.



- 9 Push down the left and right release levers M2 to the  position.

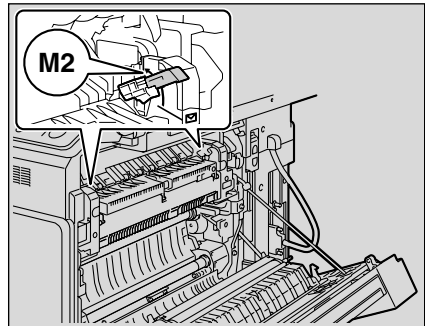

- 10 Close the fusing unit cover.

11 Close the upper right-side door.

- After printing envelopes, return the left and right M2 release levers to their center positions.



Detail

When loading paper exceeding 11 × 17 size into the 1st tray, the paper can have a width up to 12-1/4 in. and a length up to 18 in..

For details on specifying the paper size for the 1st tray, refer to “To specify a paper size (set size settings)” on page 7-11.

If special paper is loaded, the paper type setting must be specified. For details, refer to “To specify a setting for special paper” on page 7-21.



Reminder



Be careful not to touch the surface of the paper take-up roller with your hands.

If the lateral guides are not positioned correctly for the loaded paper, the paper size will not be correctly detected. Be sure to adjust the lateral guides to the size of the loaded paper.

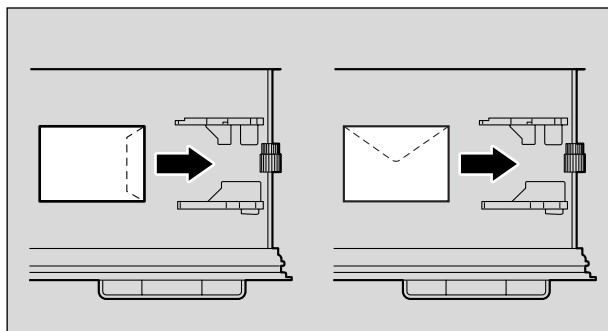

Before loading envelopes, press them down to make sure that all air is removed, and make sure that the folds of the flaps are firmly pressed, otherwise the envelopes may become wrinkled or a paper misfeed may occur.

When loading envelopes, load them in the  orientation with the flap side down, as shown in the illustration. If the envelopes are loaded with the flap side up, a paper misfeed may occur. The flap side of envelopes cannot be printed on.

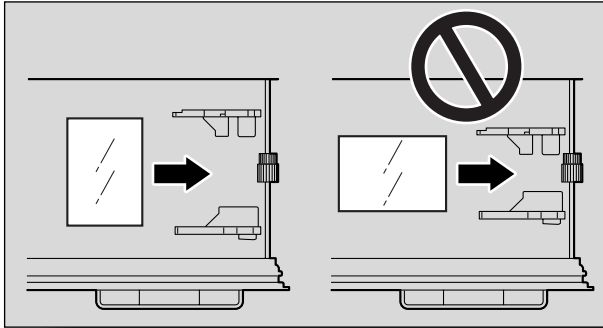

When loading overhead projector transparencies, load them in the  orientation, as shown in the illustration. Do not load overhead projector transparencies in the  orientation.



When loading postcards, load them in the  orientation, as shown in the illustration. Do not load postcards in the  orientation.

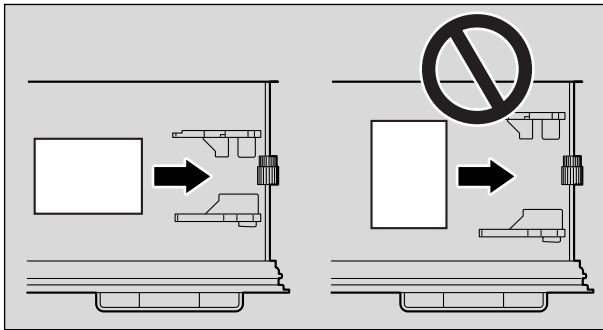

Be sure to load letterhead paper so that the side to be printed on faces down.

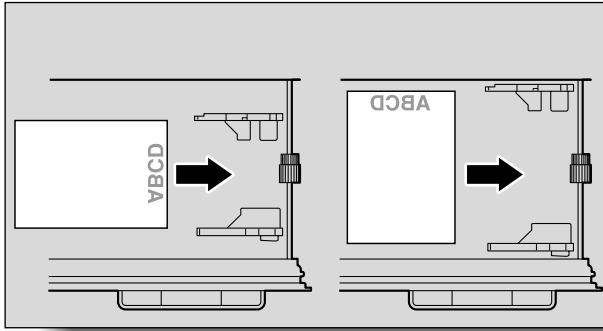

2.5 Loading paper into the 2nd, 3rd or 4th tray

To load paper (2nd, 3rd or 4th tray)

- 1 Pull out the paper tray.
- 2 Slide the lateral guides to fit the size of paper to be loaded.

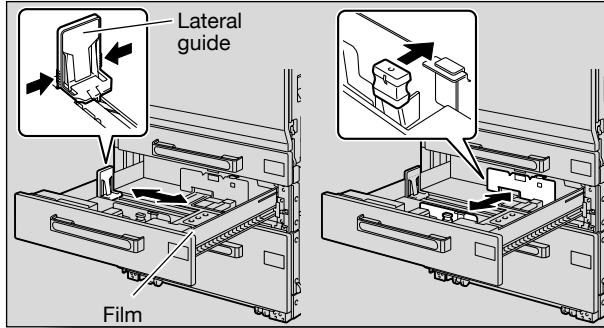

- 3 Load the paper into the tray so that the side of the paper to be printed on (the side facing up when the package was unwrapped) faces up.

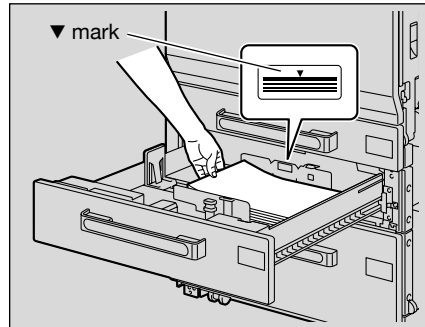

- Load letterhead paper so that the side to be printed on faces down.

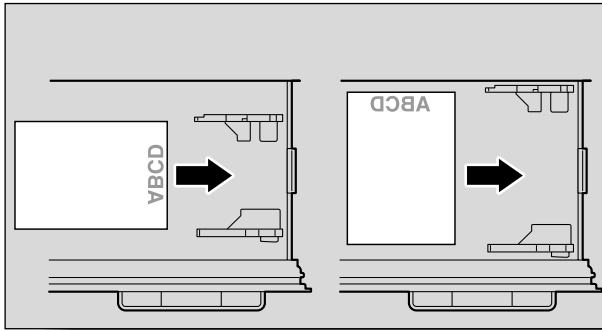

- ? How is curled paper loaded?
→ Flatten the paper before loading it.
- ? How many sheets of paper can be loaded?
→ No more than 500 sheets of plain paper can be loaded. In addition, no more than 150 sheets of thick paper can be loaded.
- Do not load so many sheets of plain paper that the top of the stack is higher than the ▼ mark.

4 Close the paper tray.



Reminder

If the lateral guides are not positioned correctly for the loaded paper, the paper size will not be correctly detected. Be sure to adjust the lateral guides to the size of the loaded paper.

For details on the paper that can be loaded into the 2nd tray, 3rd tray and 4th tray, refer to "Copy paper/original documents" on page 7-2.

Be careful not to touch the film.



Note

To print on overhead projector transparencies and envelopes, use the bypass tray or the 1st tray.

2.6 Loading paper into the LCT

To load paper (LCT)

- ✓ If the [Power] (auxiliary power) key is turned off, even while the main power switch is on, the LCT cannot be pulled out, even after the tray release button is pressed. Be sure that the machine is turned on with the [Power] (auxiliary power) key.

- 1 Press the tray release button.

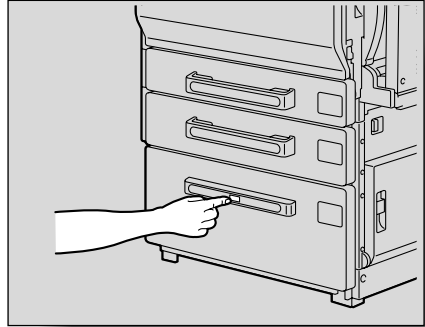

- 2 Pull out the LCT.

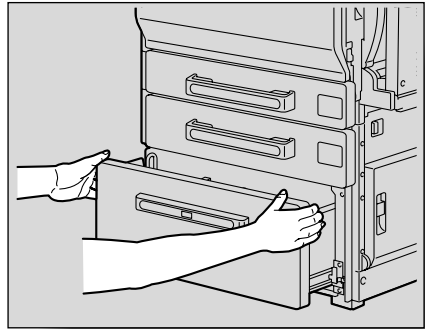

- 3 Load the paper into the right side of the LCT so that the side of the paper to be printed on (the side facing up when the package was unwrapped) faces up.

- ? How is curled paper loaded?
→ Flatten the paper before loading it.

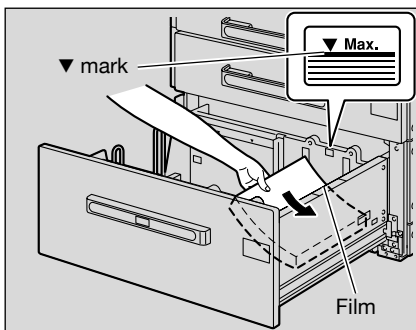

- 4 Load the paper into the left side of the LCT so that the side of the paper to be printed on (the side facing up when the package was unwrapped) faces up.

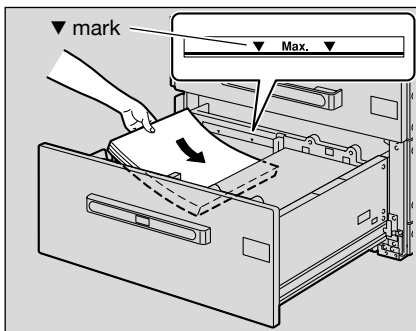

- Load letterhead paper so that the side to be printed on faces down.

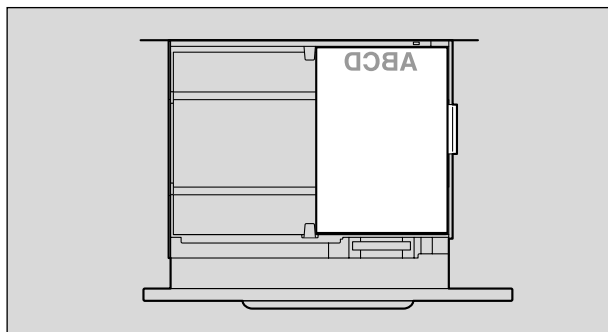

- 5 Close the LCT.



...

Reminder

Be careful not to touch the film.

Do not load so many sheets of paper that the top of the stack is higher than the ▼ mark.

For details on the paper that can be loaded into the LCT, refer to “Copy paper/original documents” on page 7-2.



...

Note

If the machine has entered Low Power mode or Sleep mode, the LCT cannot be pulled out, even after the tray release button is pressed. Be sure to first cancel Low Power mode or Sleep mode.

2.7 Loading paper into the bypass tray

Paper can be fed manually through the bypass tray if you wish to copy onto paper that is not loaded into a paper tray, or if you wish to copy onto thick paper, postcards, envelopes, overhead projector transparencies or label sheets.

To load paper (bypass tray)

- 1 Open the bypass tray.
 - When loading large-sized paper, pull out the tray extension.

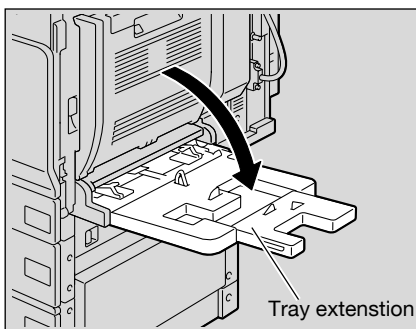

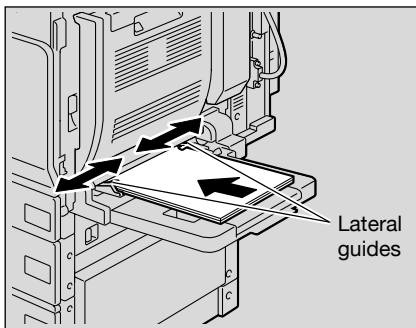

- 2 With the side to be printed on facing down, insert the paper as much as possible into the feed slot.

- 3 Slide the lateral guides to fit the size of paper being loaded.

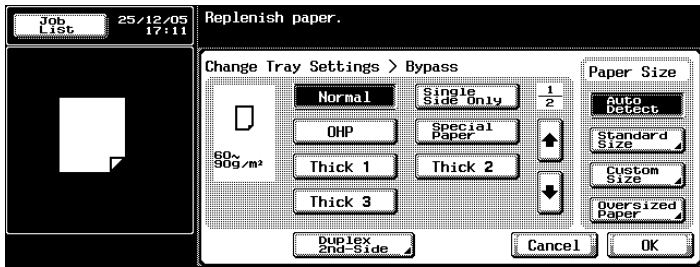

4 Select the paper type.



- To print on colored paper, envelopes or letterheads, touch [], and then select the paper type.

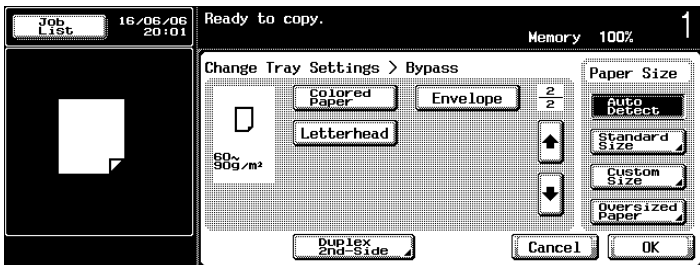

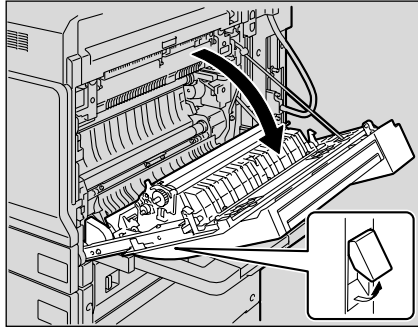

- If "A6 Card 
- If envelopes are loaded, continue with step 5.
- For details on selecting a setting for non-standard-size paper, refer to "To specify a non-standard paper size (Custom Size settings)" on page 7-13.
- For details on selecting a setting for wide paper, refer to "To specify a setting for oversized paper (Oversized Paper settings)" on page 7-18.
- For details on special paper, refer to "Special paper" on page 7-5.
- ? What should be done if media other than postcards are inserted?
→ Select the appropriate paper type.
- ? What paper type is selected when label sheets are loaded?
→ Select "Thick 1".

- 5 Pull up the upper right-side door release lever, and then open the upper right-side door.

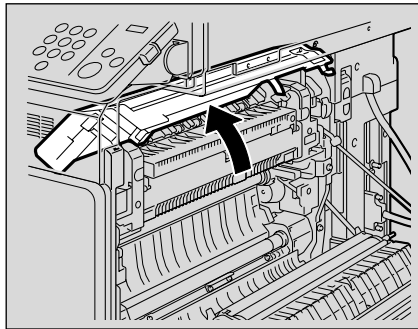

- 6 Push up the fusing unit cover.



- 7 Push down the left and right release levers M2 to the  position.

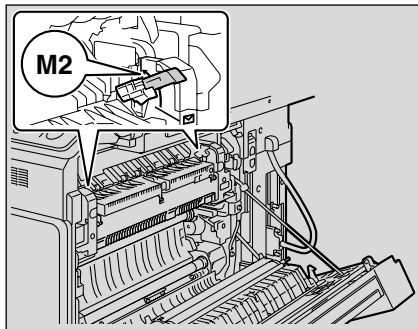

- 8 Close the fusing unit cover.

- 9 Close the upper right-side door.



Reminder

After printing on envelopes, return the left and right M2 release levers to their center positions, otherwise decreased image quality may result when printing on plain paper.



Do not load so many sheets that the top of the stack is higher than the ▲ mark.

Push the paper guides firmly up against the edges of the paper.

When loading postcards, load them in the □ orientation, as shown in the illustration. Do not load postcards in the ▣ orientation.

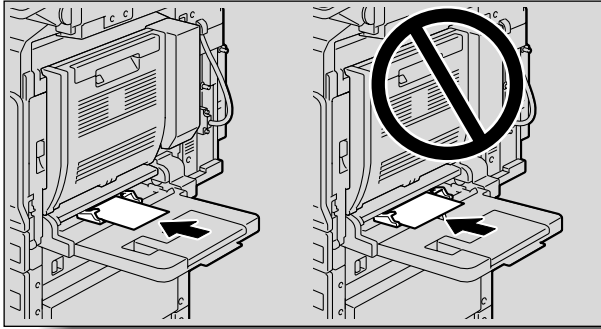
A maximum of 20 postcards can be loaded into the bypass tray.



When loading overhead projector transparencies, load them in the  orientation, as shown in the illustration. Do not load overhead projector transparencies in the  orientation.

A maximum of 20 overhead projector transparencies can be loaded into the bypass tray.

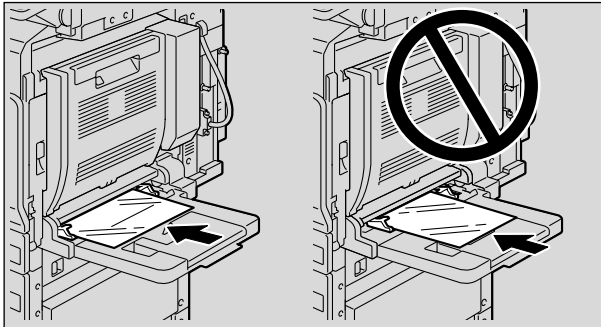



Before loading envelopes, press them down to make sure that all air is removed, and make sure that the folds of the flaps are firmly pressed, otherwise the envelopes may become wrinkled or a paper misfeed may occur.

When loading envelopes, load them with the flap side up, as shown in the illustration. If the envelopes are loaded with the flap side down, a paper misfeed may occur. The flap side of envelopes cannot be printed on.

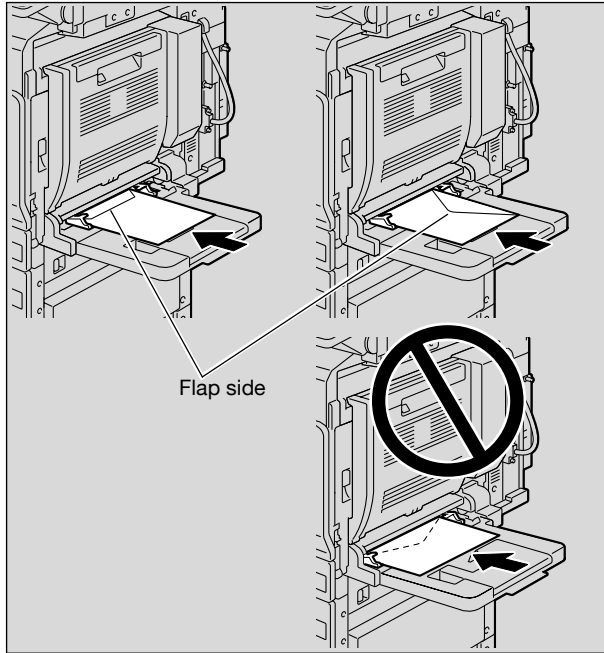
A maximum of 10 envelopes can be loaded into the bypass tray.



When loading label sheets, load them in the  orientation, as shown in the illustration. Do not load label sheets in the  orientation.

A maximum of 20 label sheets can be loaded into the bypass tray.

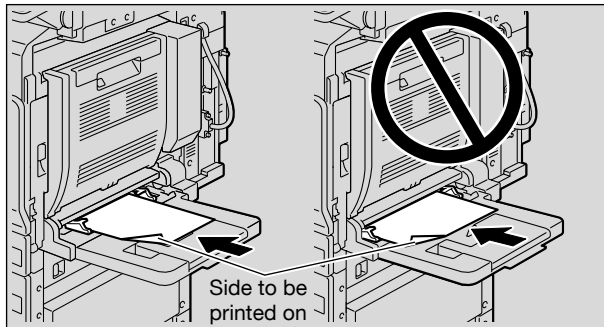

Be sure to load letterhead paper so that the side to be printed on faces up.

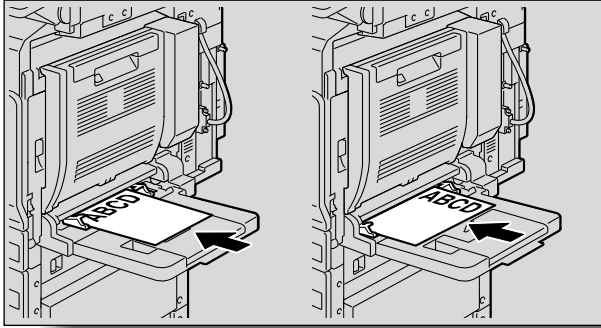
**Note**

The image will be printed on the surface of the paper facing down when the paper is loaded into the bypass tray.

**Detail**

For details on specifying the paper size for the bypass tray, refer to “To specify a paper size (set size settings)” on page 7-11.

For details on the paper sizes, refer to “Copy paper” on page 7-2.



Basic copy operations

3 Basic copy operations

3.1 General copy operation

This section contains information on the general operation for making copies. The following procedure describes how to copy a single-sided document using basic copy operations.



Note

Some settings cannot be used together. For details on the settings that cannot be combined, refer to "Operations that cannot be combined" on page 3-5.

To make a copy

- 1 Press the [Copy] key to display the Basic screen in Copy mode.
- 2 Position the document to be copied.
 - For details on positioning the document, refer to "Feeding the document" on page 3-7.

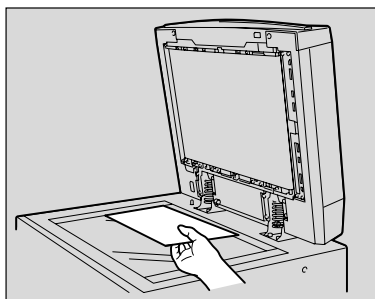
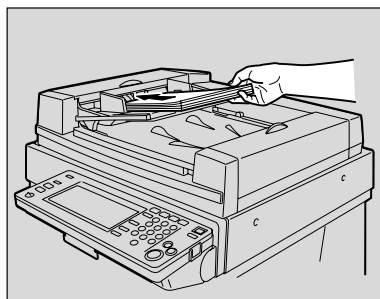

3 Specify the necessary copy settings.

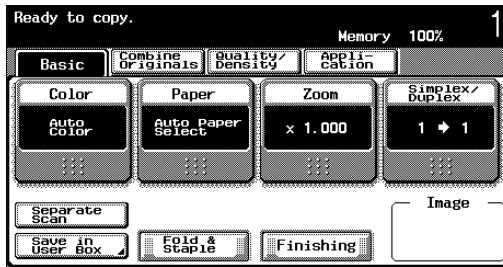

- The default settings when this machine is purchased are listed below.

[Color]: Auto Color

[Paper]: Auto Paper Select

[Zoom]: Full size (× 1.000)

[Simplex/Duplex]: 1→1

[Quality/Density]: Text/Photo

- For details on specifying Original settings, refer to “Specifying original settings” on page 3-20.
- For details on selecting a Color setting, refer to “Selecting a color setting” on page 3-32.
- For details on selecting a Paper setting, refer to “Selecting a paper setting” on page 3-35.
- For details on specifying a Zoom setting, refer to “Specifying a zoom setting” on page 3-38.
- For details on specifying a Simplex/Duplex setting, refer to “Selecting the document and copy type settings (Simplex/Duplex settings)” on page 3-49.
- For details on selecting the quality of the document, refer to “Selecting the quality of the document” on page 3-55.
- For details on specifying the density settings, refer to “Specifying the density settings” on page 3-59.
- For details on selecting a Combine Originals setting, refer to “Selecting a combine originals setting” on page 3-64.
- For details on selecting Finishing settings, refer to “Selecting finishing settings” on page 3-67.
- For details on specifying the “Fold & Staple” function, refer to “Specifying center binding” on page 3-80.
- For details on specifying settings for the Application functions, refer to “Application functions” on page 8-2.

4 Using the keypad, type in the desired number of copies.

- If the number of copies was incorrectly entered, press the [C] (clear) key in the keypad, and then specify the correct number of copies.

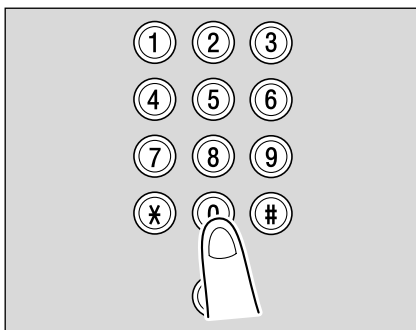

5 Press the [Start] key.

- To stop the copy operation being performed, press the [Stop] key. For details, refer to “Stopping scanning/printing” on page 3-86.
- The next copy operation can be queued while a copy operation is being performed. For details, refer to “Scanning the next document to be copied while a copy job is being printed (next job reservation)” on page 3-84.

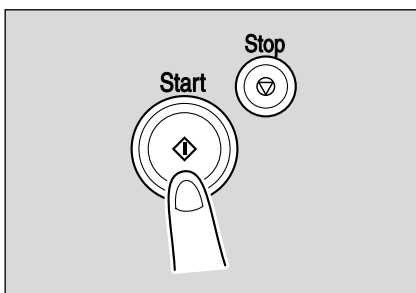

3.2 Operations that cannot be combined

Certain copy settings cannot be used together.

Specifying settings that cannot be combined will result in one of the following occurring.

- The setting specified last is given priority. (The setting specified first is canceled.)
- The setting specified first is given priority. (A warning message appears.)

Operations where the setting specified last is given priority

The procedure for setting the “Booklet” function after selecting the “2 Position” Staple setting is described below.

- 1 Select the [2 Position] Staple setting.

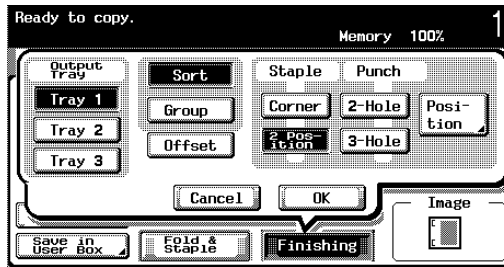

- 2 Set the “Booklet” function.

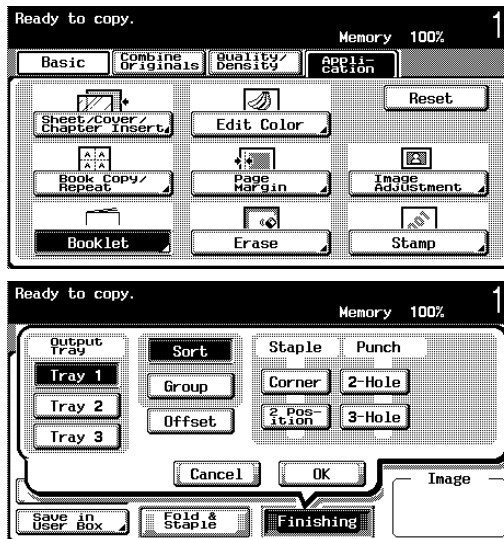

The “2 Position” Staple setting is automatically cancelled, and the “Booklet” function is set.

To select the “2 Position” Staple setting, cancel the “Booklet” function, and then select the “2 Position” setting.

Operations where the setting specified first is given priority

If a warning message appears, indicating that settings cannot be combined, those settings cannot be specified together.

The procedure for selecting the “2 Position” Staple setting after setting the “Booklet” function is described below.

- 1 Set the “Booklet” function.

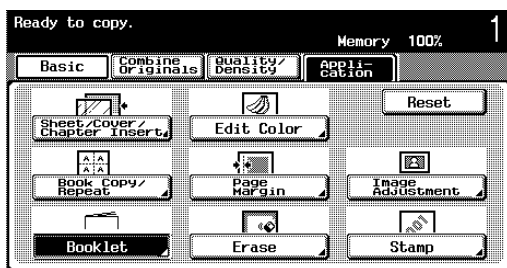

- 2 Select the “2 Position” Staple setting.

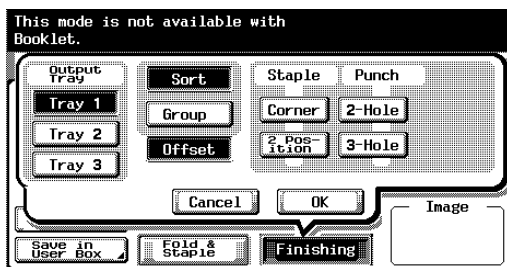

The message “This mode is not available with Booklet.” appears and the “2 Position” Staple setting cannot be selected.

The “Booklet” function remains selected and the “2 Position” Staple setting is canceled.

To select the “2 Position” Staple setting, cancel the “Booklet” function, and then select the “2 Position” setting.

3.3 Feeding the document

The document can be fed in either of the following two ways. Be sure to position the document correctly according to the type of document being copied.

Document Feed Method	Features
Using the ADF	By using the ADF, a multi-page document can be fed automatically. This feed method can also be used with double-sided documents, and is perfect for multi-page double-sided documents.
Using the original glass	The document is placed directly on the original glass, then scanned. This method is best with books and other documents that cannot be fed through the ADF.

To load the document into the ADF

- ✓ The ADF is an option.
- ✓ For details on the types of documents that can be loaded into the ADF, refer to “Original documents” on page 7-25.
- ✓ Do not load documents that are bound together, for example, with paper clips or staples.
- ✓ Do not load more than 100 sheets or so many sheets that the top of the stack is higher than the ▼ mark, otherwise a document misfeed or damage to the document or machine may occur. However, a document that exceeds 100 pages can be scanned in separate batches. For details, refer to “Scanning the document in separate batches (“Separate Scan” setting)” on page 3-11.
- ✓ If the document is not loaded correctly, the document may not be fed in straight or a document misfeed or damage to the document may occur.

- 1 Slide the adjustable document guides to fit the size of the document.
 - If large-sized documents are to be loaded, pull out the document support.

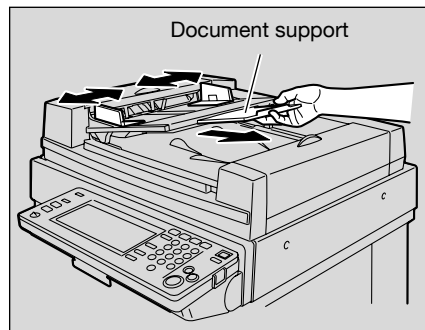

- 2 Load the document face up in the document feed tray.

- Load the document pages so that the top of the document is toward the back or the right side of the machine.

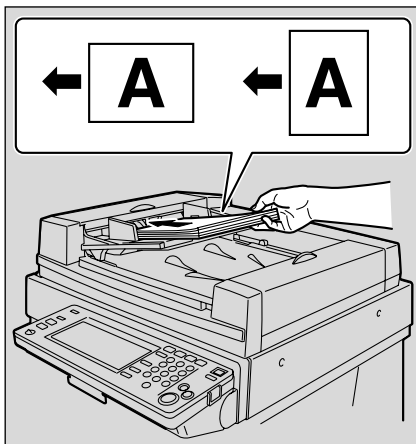

- 3 Adjust the document guides to the size of the document.

- For details on loading documents of mixed sizes, refer to “Copying documents of mixed sizes (“Mixed Original” setting)” on page 3-20.
- For details on loading thick documents, refer to “Copying thick documents (“Thick Original” setting)” on page 3-22.
- For details on selecting the document orientation, refer to “Selecting the document orientation (Original Direction settings)” on page 3-24.
- For details on selecting the position of the binding margin, refer to “Selecting the position of the binding margin (Margin settings)” on page 3-26.

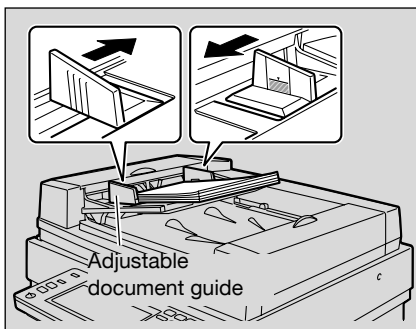

To place the document on the original glass

- ✓ For details on the types of documents that can be placed on the original glass, refer to “Original documents” on page 7-25.
- ✓ When placing the document on the original glass, be sure to lift open the ADF at least 20°. If the document is placed on the original glass without the ADF being lifted at least 20°, the correct document size will not be detected.
- ✓ Do not place objects weighing more than 4-1/2 lb on the original glass. In addition, do not press down extremely hard on a book spread placed on the original glass, otherwise the original glass may be damaged.
- ✓ For thick books or large objects, make the copy without closing the original cover, or ADF if it is installed. When a document is being scanned with the original cover or ADF open, do not look directly at the light that may shine through the original glass. Although the light that shines through the original glass is bright, it is not a laser beam and, therefore, is not as dangerous.

- 1 Lift open the original cover, or the ADF if it is installed.
- 2 Position the document face down onto the original glass.
 - Load the document pages so that the top of the document is toward the back or the left side of the machine.

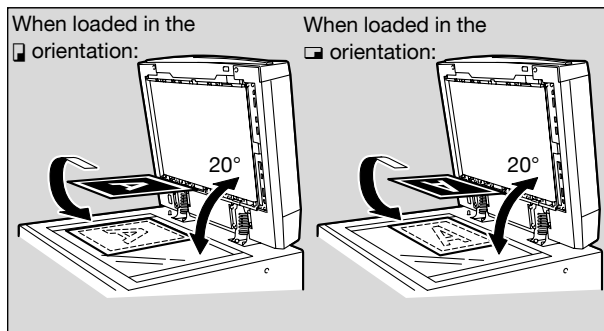

3 Align the document with the  mark in the back-left corner of the document scales.

- For details on selecting the document orientation, refer to “Selecting the document orientation (Original Direction settings)” on page 3-24.
- For details on selecting the position of the binding margin, refer “Selecting the position of the binding margin (Margin settings)” on page 3-26.
- For transparent or translucent documents, place a blank sheet of paper of the same size as the document over the document.

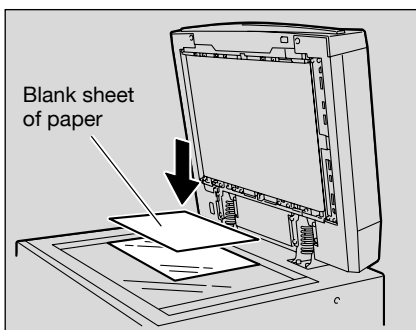
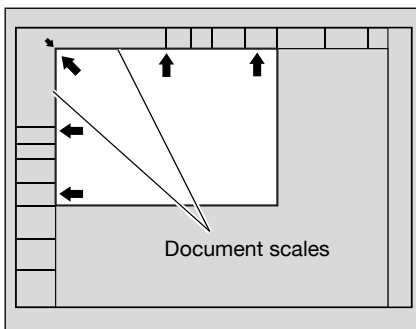

- For bound documents spread over two facing pages, such as a book or magazine, position the top of the document toward the back of this machine and align the document with the  mark in the back-left corner of the document scales, as shown.

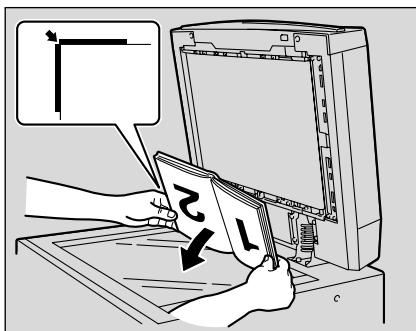

4 Close the original cover, or the ADF if it is installed.

Scanning the document in separate batches (“Separate Scan” setting)

A large document can be divided and scanned in a number of batches.

A maximum of 100 document pages can be loaded into the ADF at one time. However, by copying with the “Separate Scan” setting, a document that exceeds 100 pages can be scanned and treated as a single copy job. In addition, the scanning location can be switched between the original glass and the ADF during the scanning operation.

- ✓ The loading capacity of the ADF is 100 sheets of plain paper (21-1/4 lb) or 38 sheets of thick paper (55-3/4 lb).
- ✓ Either “Auto Print” or “Batch Print” can be selected as the print setting when scanning with the “Separate Scan” setting. The default setting is “Auto Print”. For details on selecting the print setting for scanning with the “Separate Scan” setting, refer to “Copier setting” on page 12-22.

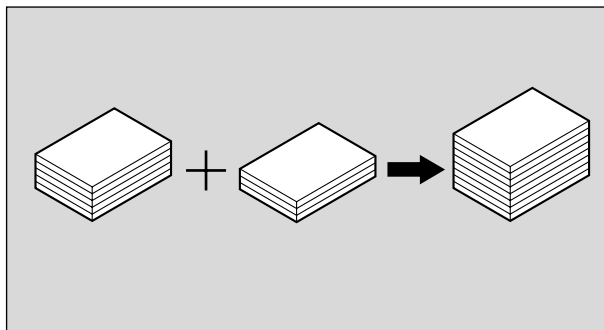

- ✓ For details on positioning the document, refer to “Feeding the document” on page 3-7.

- 1 Position the document to be copied.
- 2 In the Basic screen, touch [Separate Scan].

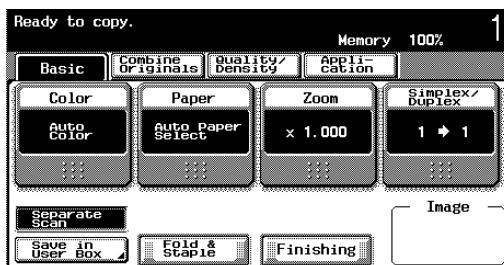

- To cancel the “Separate Scan” setting, touch [Separate Scan] again to deselect it.

- 3 Press the [Start] key.
Scanning begins.

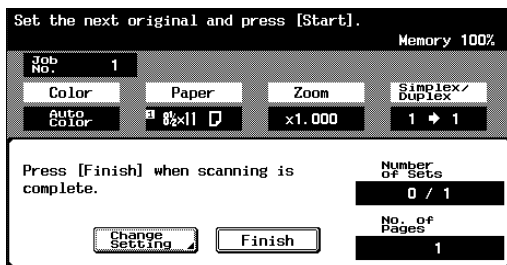

- If the “Print Setting for Separate Scan” parameter is set to “Batch Print”, touch [Finish] in the following screen, which appears while the document is scanned with the ADF, to continue to step 5.

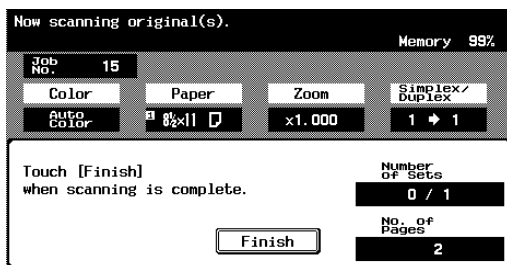

- 4 Load the next batch of the document, and then press the [Start] key.
- Repeat this step until all pages of the document have been scanned.
 - If the document cannot be loaded into the ADF, place it on the original glass. For details on the types of documents that can be loaded into the ADF, refer to “Original documents” on page 7-25.
 - The amount of memory available can be checked beside “Memory” in the upper-right corner of the Basic screen.
 - To delete the image data, press the [Stop] key, and then delete the job. For details, refer to “Stopping scanning/printing” on page 3-86.
 - To change the scanning settings, touch [Change Setting]. For details on changing the scanning settings, refer to “To change scan settings for each document” on page 3-29.

- The buttons that appear in the Change Setting screen differ depending on the specified settings. Settings for the following can be changed.

Simplex/Duplex, Bind, Zoom, Frame Erase, Center Erase, Original Size

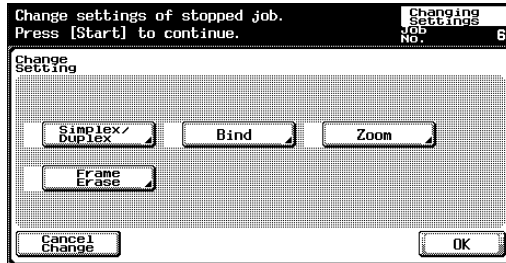

- 5 After all document pages have been scanned, touch [Finish].

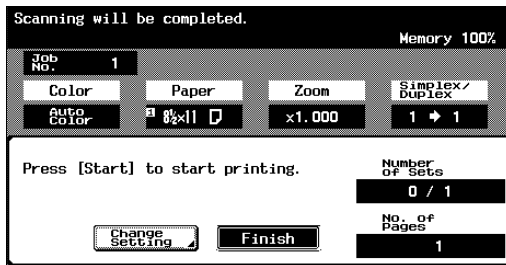

- If the “Print Setting for Separate Scan” parameter is set to “Batch Print”, touch [Yes] in the screen that appears, requesting confirmation that scanning of the document is finished. Otherwise, touch [No] is touched to return to step 3.

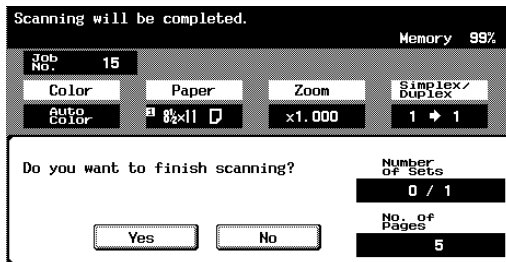

6 Press the [Start] key.

- If the “Print Setting for Separate Scan” parameter is set to “Batch Print”, touch [Print] or press the [Start] key.

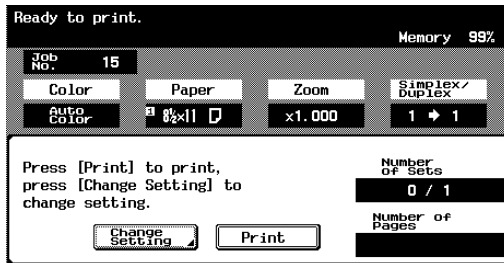

- If the “Print Setting for Separate Scan” parameter is set to “Batch Print”, the copy settings can be changed. To change the copy settings, touch [Change Setting], and then touch [OK] after changing the settings as desired. Otherwise, touch [Cancel Change] to cancel the changes to the settings.

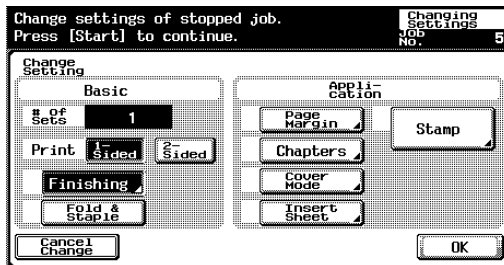

Scanning a multi-page document from the original glass

When making double-sided or combined copies using the original glass, place each page of a multi-page document on the original glass to scan it. The following procedure describes how to place single-sided document pages on the original glass to make double-sided copies.

- ✓ Either “Auto Print” or “Batch Print” can be selected as the print setting when scanning with the “Separate Scan” setting. The default setting is “Auto Print”. For details on selecting the print setting for scanning with the “Separate Scan” setting, refer to “Copier setting” on page 12-22.

- 1 Lift open the original cover, or the ADF if it is installed.
- 2 Position the first page or the first side of the document face down onto the original glass.
 - For details on positioning the document, refer to “To place the document on the original glass” on page 3-9.

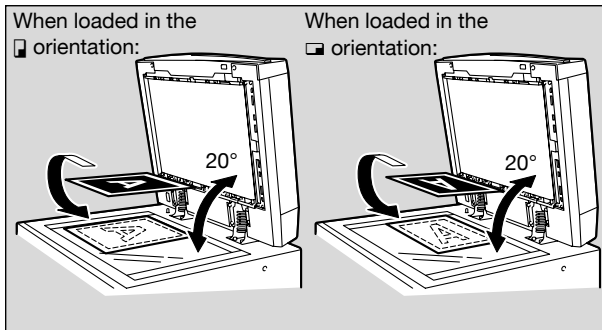

- 3 Close the original cover, or the ADF if it is installed.
- 4 In the Basic screen, touch [Simplex/Duplex].

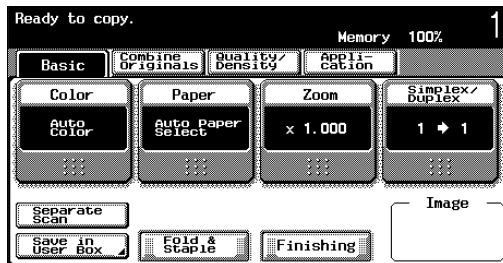

The Simplex/Duplex screen appears.

5 Touch [1→2].

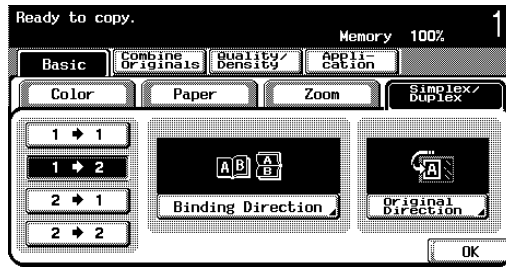

- The screens that appear differ depending on the options that are installed.

6 Touch [Binding Direction], select the binding position for the copies, and then touch [OK].

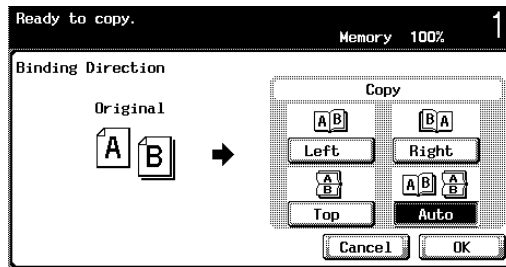

- For details on specifying the binding position, refer to “To select double-sided copies” on page 3-53.

7 Touch [Original Direction], select the orientation of the loaded document, and then touch [OK].

- For details on specifying the document orientation, refer to “Selecting the document orientation (Original Direction settings)” on page 3-24.

8 Touch [OK].

- 9 Press the [Start] key.
Scanning begins.

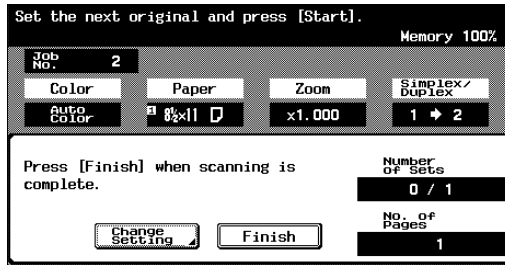

- 10 Load the next batch of the document, and then press the [Start] key.
- Repeat this step until all pages of the document have been scanned.
 - The amount of memory available can be checked beside “Memory” in the upper-right corner of the Basic screen.
 - To delete the image data, press the [Stop] key, and then delete the job. For details, refer to “Stopping scanning/printing” on page 3-86.
 - To change the scanning settings, touch [Change Setting]. For details on changing the scanning settings, refer to “To change scan settings for each document” on page 3-29.
 - The buttons that appear in the Change Setting screen differ depending on the specified settings. Settings for the following can be changed.
Simplex/Duplex, Bind, Zoom, Frame Erase, Center Erase, Original Size

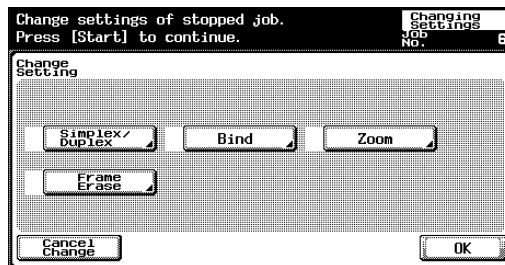

- 11 After all document pages have been scanned, touch [Finish].

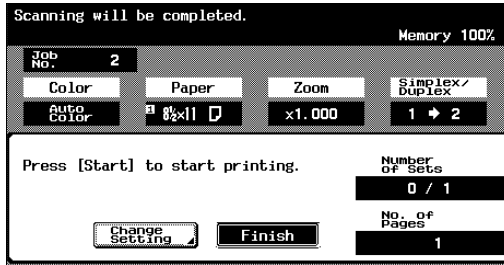

- If the “Print Setting for Separate Scan” parameter is set to “Batch Print”, touch [Yes] in the screen that appears, requesting confirmation that scanning of the document is finished. Otherwise, touch [No] is touched to return to step 9.

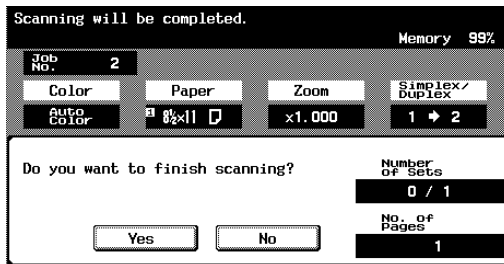

- 12 Press the [Start] key.

- If the “Print Setting for Separate Scan” parameter is set to “Batch Print”, touch [Print] or press the [Start] key.

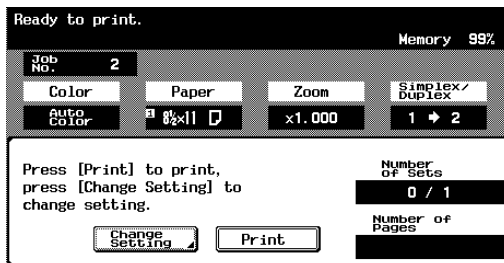

- If the “Print Setting for Separate Scan” parameter is set to “Batch Print”, the copy settings can be changed. To change the copy settings, touch [Change Setting], and then touch [OK] after changing the settings as desired. Otherwise, touch [Cancel Change] to cancel the changes to the settings.

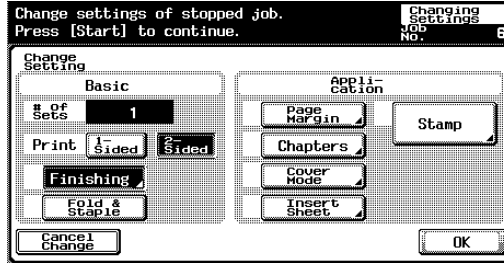

3.4 Specifying original settings

The following procedure describes how to specify the type of document to be copied.

Copying documents of mixed sizes (“Mixed Original” setting)

Documents of different sizes can be loaded together into the ADF to be fed and scanned one by one automatically.

The possible combinations of document sizes differ depending on the widest document loaded (position of the adjustable document guides of the ADF).

- ✓ Do not load more than 100 sheets or so many sheets that the top of the stack is higher than the ▼ mark, otherwise a document misfeed or damage to the document or machine may occur. However, a document that exceeds 100 pages can be scanned in separate batches. For details, refer to “Scanning the document in separate batches (“Separate Scan” setting)” on page 3-11.
 - ✓ If the document is not loaded correctly, the document may not be fed in straight or a document misfeed or damage to the document may occur.
- 1 Slide the adjustable document guides to fit the size of the largest page.
 - If large-sized documents are to be loaded, pull out the document support.
 - For details on the document sizes that can be mixed in the ADF, refer to “Documents that can be loaded into the ADF” on page 7-25.

- 2 Arrange the document pages so that the side to be copied (first page) faces up, as shown in the illustration.

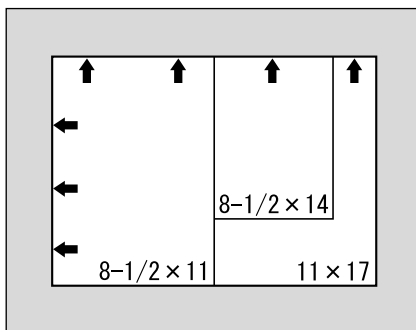

- 3 Load the document face up in the document feed tray. Slide the adjustable document guides against the edges of the document.
- Load the document pages into the ADF so that the top of the pages is toward the back or the left side of the machine.

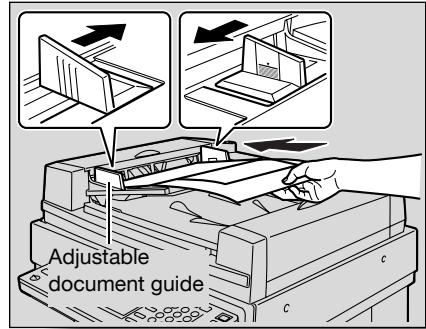

- 4 In the Basic screen, touch [Combine Originals].

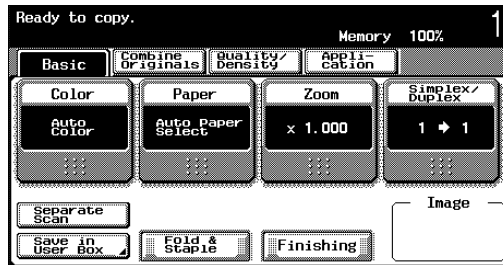

The Combine Originals and Original settings screen appears.

- 5 Touch [Mixed Original].

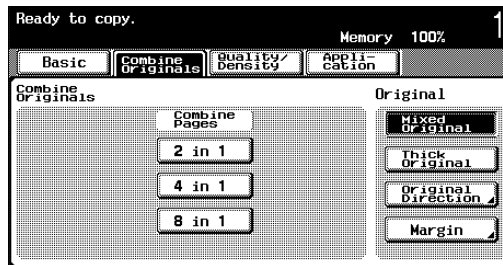

- To cancel the “Mixed Original” setting, touch [Mixed Original] again to deselect it.

Copying thick documents (“Thick Original” setting)

When copying thick documents with a weight of 34-1/4 lb to 55-3/4 lb loaded into the ADF, select the “Thick Original” setting.

- ✓ When the “Thick Original” setting is selected, a maximum of 38 document pages can be loaded into the ADF. For details on thick documents, refer to “Original documents” on page 7-25.
- ✓ For details on positioning the document, refer to “Feeding the document” on page 3-7.

- 1 Position the document to be copied.

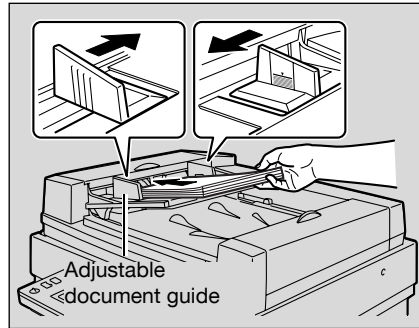

- 2 In the Basic screen, touch [Combine Originals].

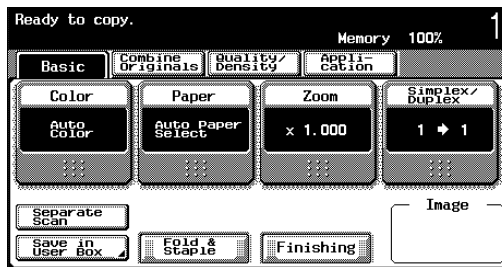

The Combine Originals and Original settings screen appears.

3 Touch [Thick Original].

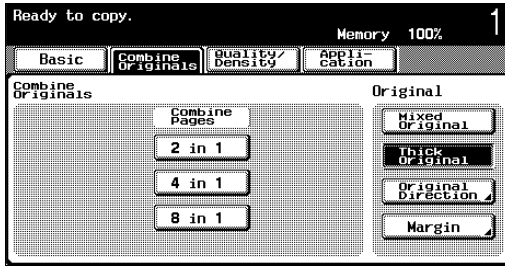

Selecting the document orientation (Original Direction settings)

When copying double-sided documents, making double-sided copies, or using a Combine Originals setting, specify the document orientation, otherwise the copies may not be printed in the correct page order or correct front and back page arrangement.



Note

The default setting is the first setting (with the top of the document at the top (toward the back of the machine)).

Document Loading Orientation

Using the ADF	Using the Original Glass	Icon	Description
			Select this setting for a document loaded with the top toward the back of this machine.
			Select this setting for a document loaded with the top toward the front of this machine.
			<ul style="list-style-type: none"> Select this setting for a document loaded into the ADF with the top of the document toward the left side of this machine. Select this setting for a document placed on the original glass with the top of the document toward the right side of this machine.
			<ul style="list-style-type: none"> Select this setting for a document loaded into the ADF with the top of the document toward the right side of this machine. Select this setting for a document placed on the original glass with the top of the document toward the left side of this machine.

To specify an original direction setting

- ✓ For details on positioning the document, refer to “Feeding the document” on page 3-7.

- 1 Position the document to be copied.
- 2 In the Basic screen, touch [Combine Originals].

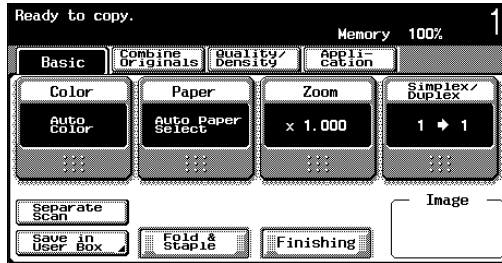

The Combine Originals and Original settings screen appears.

- 3 Touch [Original Direction].

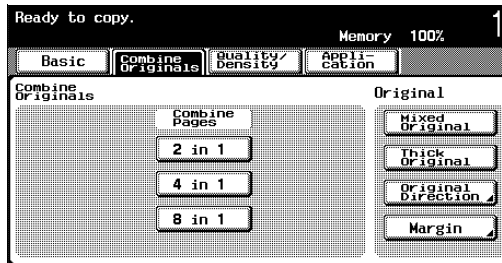

The Original Direction screen appears.

- 4 Touch the button for the orientation of the loaded document, and then touch [OK].

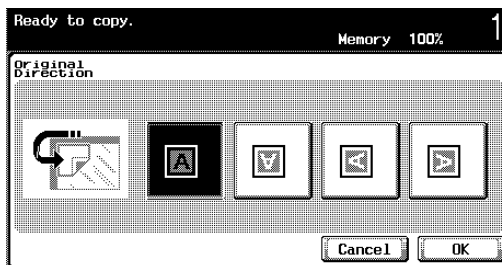

- To cancel changes to the settings, touch [Cancel].

Selecting the position of the binding margin (Margin settings)







If a double-sided document is loaded into the ADF, specify the position of the top of the back side of the document by specifying the binding margin position for the document.



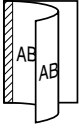

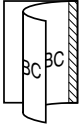
Note

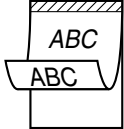
The default setting is "Auto".

Document Binding Margin Position

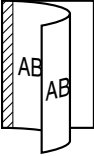
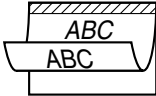
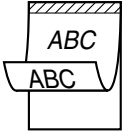
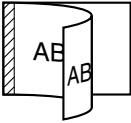
Margin Setting	Icon	Description
		Select this setting if the document is loaded with the binding margin at the left.
		Select this setting if the document is loaded with the binding margin at the right.
		Select this setting if the document is loaded with the binding margin at the top.

Margin Setting	Icon	Description
<p>When the document length is 11-11/16 in. or less:</p>   <p>When the document length is more than 11-11/16 in.:</p>  		<p>Select this setting to automatically select the position of the binding margin.</p> <p>If the document length is 11-11/16 in. or less, a binding position along the long side of the paper is selected.</p> <p>If the document length is more than 11-11/16 in., a binding position along the short side of the paper is selected.</p> <p> ...</p> <p>Note If "Auto" is selected, the binding margin is set at the top or at the left.</p>

To specify a margin setting

✓ For details on positioning the document, refer to "Feeding the document" on page 3-7.

- 1 Position the document to be copied.
 - When loading a document with a binding margin, position the top of the document toward the back of the machine.
- 2 In the Basic screen, touch [Combine Originals].

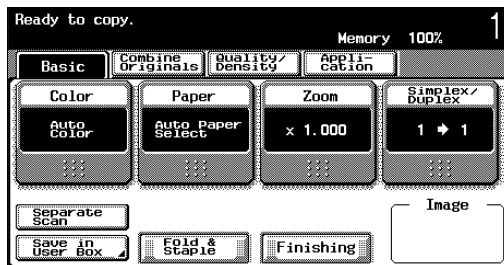

The Combine Originals and Original settings screen appears.

3 Touch [Margin].

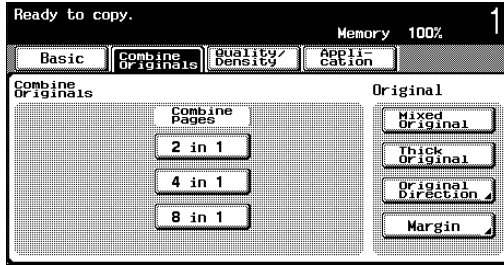

The Page Margin screen appears.

4 Touch the button for the desired margin position, and then touch [OK].

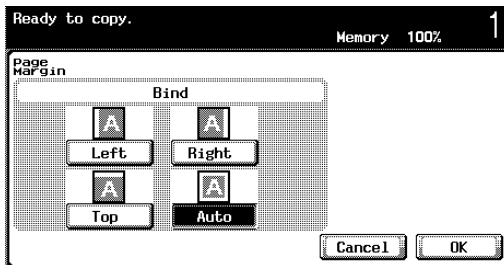

- To cancel changes to the settings, touch [Cancel].

To change scan settings for each document

When copying using the “Separate Scan” setting or when multi-page documents are placed on the original glass, the scan settings can be changed for each document. The following procedure describes how to change the settings when the “Separate Scan” setting is used.

- 1 Position the document to be copied.
- 2 In the Basic screen, touch [Separate Scan].

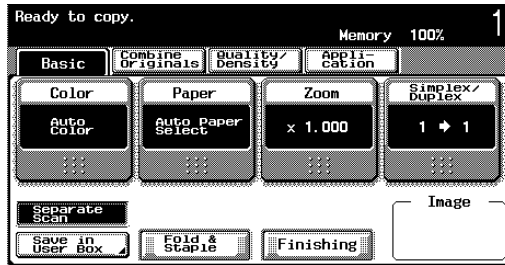

- 3 Press the [Start] key.
Scanning begins.
- 4 Touch [Change Setting].

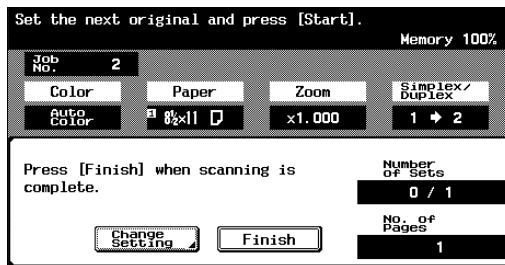

A screen appears, allowing you to change the settings.

- 5 Touch the key of the setting to be changed, select the desired setting, and then touch [OK].
- The buttons that appear in the Change Setting screen differ depending on the specified settings. Settings for the following can be changed.
Simplex/Duplex, Bind, Zoom, Frame Erase, Center Erase, Original Size
 - To cancel changes to the settings, touch [Cancel Change].

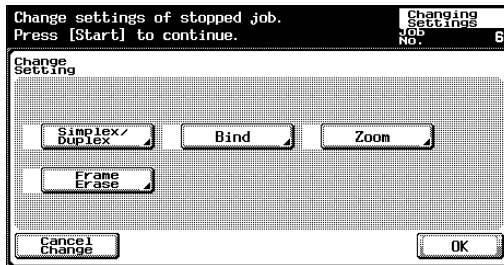

Simplex/Duplex screen

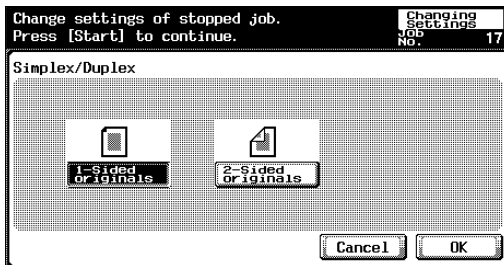

Original Bind Position screen

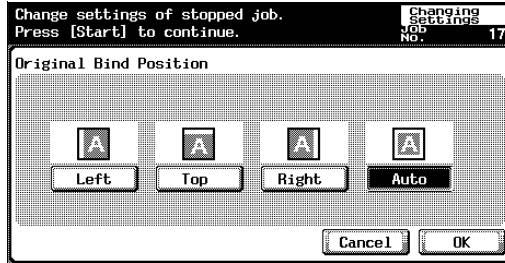

Center Eraser screen

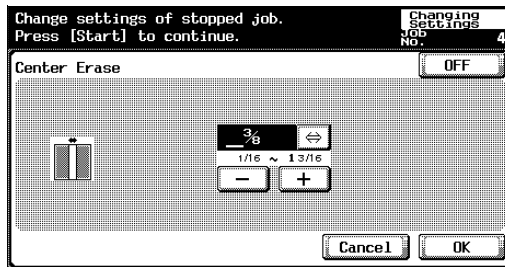

Original Size Setting screen

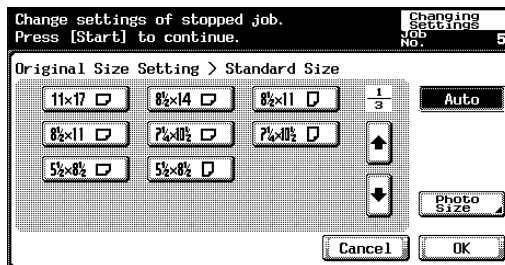

- For details on specifying the Zoom setting, refer to “Specifying a zoom setting” on page 3-38. For details on specifying a zoom ratio, refer to “Erasing specified areas of copies (“Erase” function)” on page 8-61.

3.5 Selecting a color setting

The following five Color settings are available.



Note

The default setting is “Auto Color”.

Color Setting	Description
Auto Color	Select this setting to automatically detect whether the scanned document is in color or in black and white, and then select the appropriate Color setting (“Full Color” or “Black”).
Full Color	Select this setting to print the copy in full color, regardless of whether the scanned document is in color or in black and white.
2 Color	Select this setting to print all areas of the scanned document determined to be in color with the specified color, and print all areas determined to be black in black. (The color used for the areas printed in color are: red, yellow, blue, magenta, green or cyan. Refer to page x-44.)
Black	Select this setting to print the copy in black and white, regardless of whether the scanned document is in color or in black and white.
Single Color	Select this setting to print copies in the specified color, regardless of whether the scanned document is in color or in black and white. (The color used for printing the copy can be set to one of the 21 available. Refer to page x-43.) When the “Single Color” setting is selected, the following two methods for reproducing gradations in documents are available. <u>Relative luminosity</u> : The document will be copied using monochrome concentration variations to express color differences (color shading that can be seen with the eye) and gradation levels. This enables the color of markers, the blue lines in graphing paper and the red of stamps to be distinctly reproduced in copies. <u>Average brightness</u> : The document will be copied using monochrome concentration variations to only express gradation levels, regardless of the color differences in the original document. This is useful for producing monochrome copies of documents containing gradation differences, such as magazines and newspapers, and for offsetting the yellow tint in documents that have yellowed. To select this method, touch [Solid].

To select a color setting

The following procedure describes how to select a Color setting.

- 1 In the Basic screen, touch [Color].

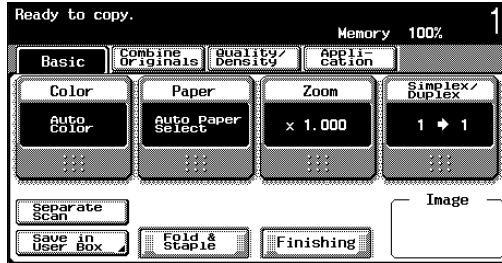

The Color screen appears.

- 2 Touch the button for the desired Color setting.

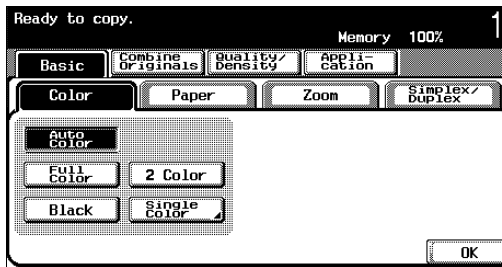

- If the “2 Color” setting was selected, touch the button for the desired color, and then touch [OK]. One of the colors for the “2 Color” setting is black, which cannot be changed. In this step, touch the button for the second color.

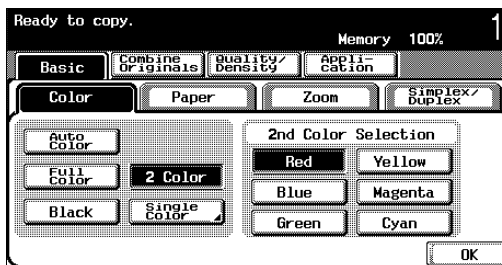

- If the “Single Color” setting was selected, touch the button for the desired color, and then touch [OK].

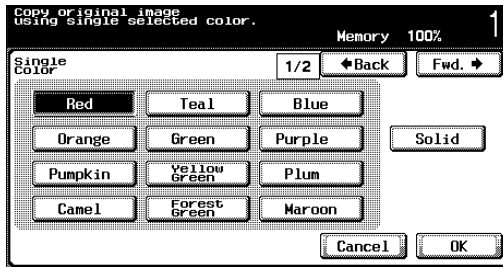

- Touch [← Back] or [Fwd. →], and then select the desired color. If desired, touch [Solid].
- If the “Solid” setting is not selected, the relative luminosity method is selected.
- To use the average brightness method for reproducing gradations in monochrome documents, touch [Solid].

3 Touch [OK].

The Basic screen appears again.

3.6 Selecting a paper setting

The paper size can be selected automatically according to the document size or it can be specified manually. Specify the paper size according to the corresponding procedure, depending on the desired copy settings.



Note

If a setting for special paper is selected for a paper tray, that tray is not selected automatically with the “Auto Paper Select” setting. (However, a paper tray set to “Single Side Only” is given priority to be selected.) This setting is useful for paper trays loaded with special paper. For details, refer to “To specify a setting for special paper” on page 7-21.

The default setting is “Auto Paper Select”.

For details on the operations that cannot be combined, refer to “Operations that cannot be combined” on page 3-5.

The “Auto Zoom” and “Auto Paper Select” settings cannot be selected at the same time. If the “Auto Zoom” setting was selected, the Zoom screen appears. In the Zoom screen, specify the desired zoom setting.

Automatically selecting the paper size (“Auto Paper Select” setting)

The size of the loaded document is detected, and copies are produced using paper of the same size.

If the “×1.0” Zoom setting was specified, paper of the same size as the document is selected.

If the zoom ratio was increased or decreased, a paper size that corresponds to the specified zoom ratio is automatically selected.

- 1 In the Basic screen, touch [Paper].

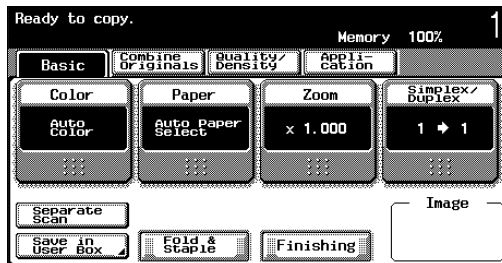

The Paper screen appears.

- 2 Touch [Auto Paper Select].

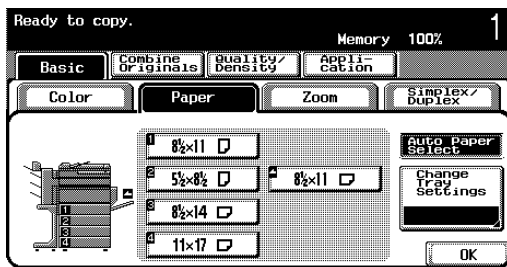

- 3 Touch [OK].
The Basic screen appears again.

Manually selecting the desired paper size

- ✓ By also selecting the “Auto Zoom” setting, the most appropriate zoom ratio is selected based on the size of the loaded document and the specified paper size. For details on the “Auto Zoom” setting, refer to “Automatically selecting the paper size (“Auto Paper Select” setting)” on page 3-35.

- 1 In the Basic screen, touch [Paper].

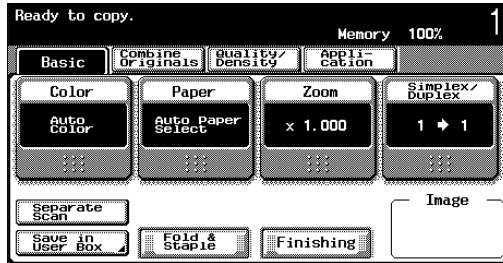

The Paper screen appears.

- 2 Select the paper tray loaded with the desired paper.

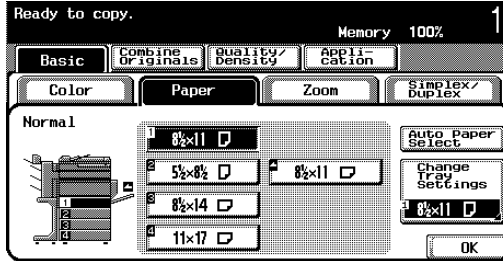

- 3 Touch [OK].

The Basic screen appears again.

3.7 Specifying a zoom setting

The zoom ratio can be set in order to make a copy on paper with a size different than the document or to enlarge or reduce the size of the copy image.

The following procedure describes how to specify the Zoom setting.

Automatically selecting the zoom ratio (“Auto Zoom” setting)

The most appropriate zoom ratio is automatically selected based on the size of the loaded document and the specified paper size.

- ✓ The default setting is “x1.0”.
- ✓ The “Auto Zoom” and “Auto Paper Select” settings cannot be selected together. If the “Auto Paper Select” setting was selected, the Paper screen appears. In the Paper screen, specify the desired Paper setting.
- ✓ If the “Auto Zoom” setting is selected and an enlargement is to be copied on paper larger than the document, load the document with the same orientation as the paper.

- 1 In the Basic screen, touch [Zoom].

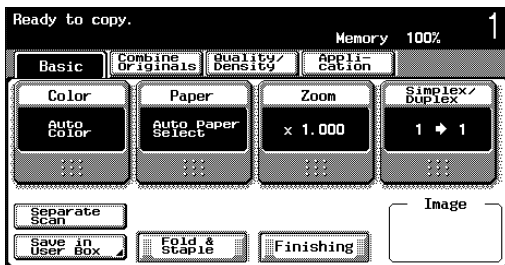

The Zoom screen appears.

- 2 Touch [Auto Zoom].

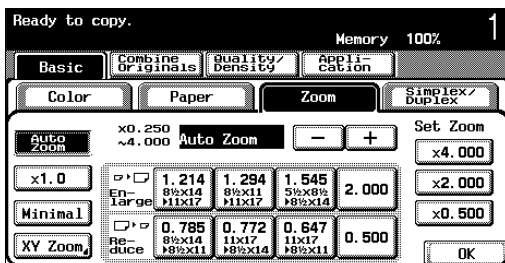

- 3 Touch [OK].

The Basic screen appears again.

Specifying the same zoom ratio as the document (“×1.0” setting)

A copy that is the same size as the document (×1.000) is produced.

- ✓ The default setting is “×1.0”.
- ✓ Touch [+] to enlarge the zoom ratio, and touch [-] to reduce the zoom ratio in ×0.001 intervals.

- 1 In the Basic screen, touch [Zoom].

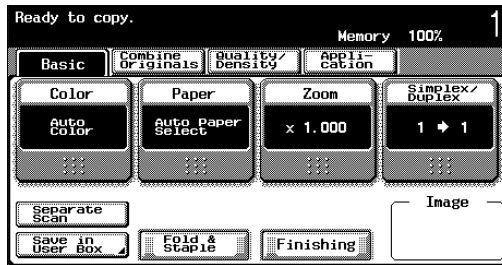

The Zoom screen appears.

- 2 Touch [×1.0].

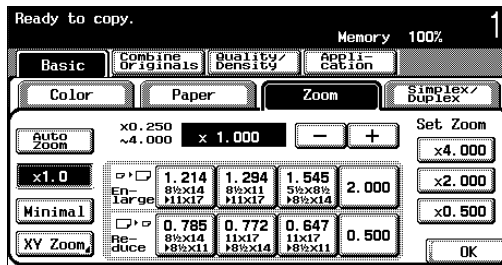

- 3 Touch [OK].

The Basic screen appears again.

Slightly reducing the copy (“Minimal” setting)

A document image can be printed slightly smaller ($\times 0.930$) than the original document size.

- ✓ The default setting is “ $\times 1.0$ ”.
- ✓ Touch [+] to enlarge the zoom ratio, and touch [-] to reduce the zoom ratio in $\times 0.001$ increments.
- ✓ The zoom ratio of the “Minimal” setting can be changed (between $\times 0.900$ and $\times 0.999$). For details on changing the zoom ratio for the “Minimal” setting, refer to “Storing the desired zoom ratio” on page 3-47.

- 1 In the Basic screen, touch [Zoom].

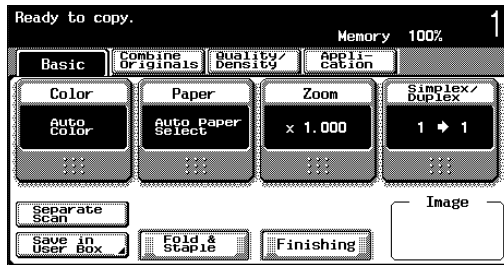

The Zoom screen appears.

- 2 Touch [Minimal].

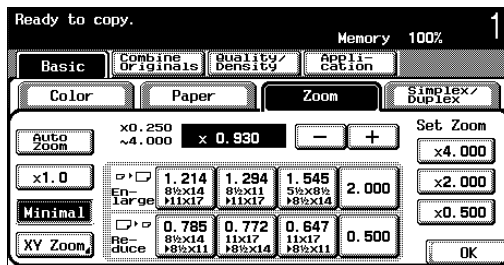

- 3 Touch [OK].

The Basic screen appears again.

Selecting a preset zoom ratio (enlarge and reduce settings)

The most appropriate zoom ratio can be selected for copying from a common standard document size to a standard paper size.

- ✓ The default setting is “×1.0”.
- ✓ Touch [+] to enlarge the zoom ratio, and touch [-] to reduce the zoom ratio in ×0.001 increments.

- 1 In the Basic screen, touch [Zoom].

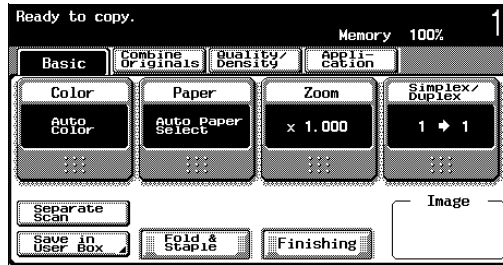

The Zoom screen appears.

- 2 Touch the button for the appropriate zoom ratio according to the document and paper sizes.

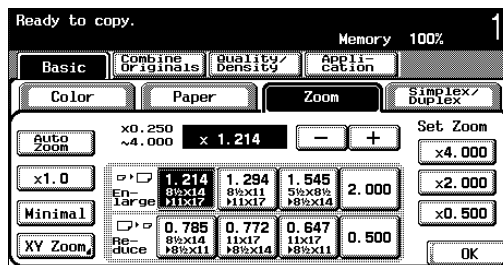

- 3 Touch [OK].

The Basic screen appears again.

Typing In the zoom ratio (XY Zoom setting)

By using the keypad, a zoom ratio between $\times 0.250$ and $\times 4.000$ can be typed in directly without changing the height-to-width ratio.

- ✓ If a value outside of the allowable range is specified, the message “Input Error” appears. Type in a value within the allowable range. If the value was incorrectly entered, press the [C] (clear) key to erase the value, and then specify the correct value.
- ✓ The entered zoom ratio can be stored. For details on storing the zoom ratio, refer to “Storing the desired zoom ratio” on page 3-47.

- 1 In the Basic screen, touch [Zoom].

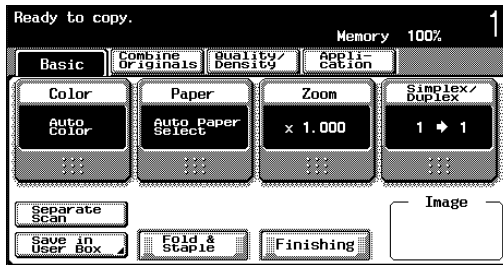

The Zoom screen appears.

- 2 Touch [XY Zoom].

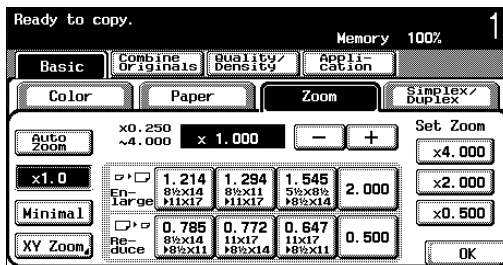

- 3 Use the keypad to type in the desired zoom ratio.

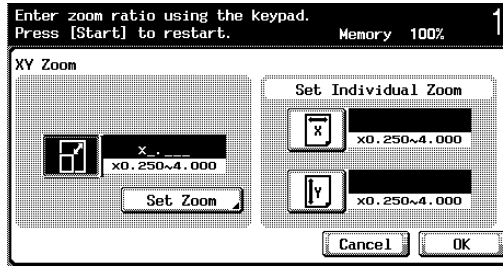

- To cancel changes to the settings, touch [Cancel].
- 4 Touch [OK], and then touch [OK] in the next screen that appears. The Basic screen appears again.

Typing In separate X and Y zoom ratios (independent zoom settings)

By using the keypad, separate zoom ratios can be typed in directly for the horizontal direction (between $\times 0.250$ and $\times 4.000$) and for the vertical direction (between $\times 0.250$ and $\times 4.000$).

By combining different horizontal and vertical zoom ratios, the copy image can be adjusted as shown in the following illustration.

- ✓ If a value outside of the allowable range is specified, the message “Input Error” appears. Type in a value within the allowable range. If the value was incorrectly entered, press the [C] (clear) key to erase the value, and then specify the correct value.

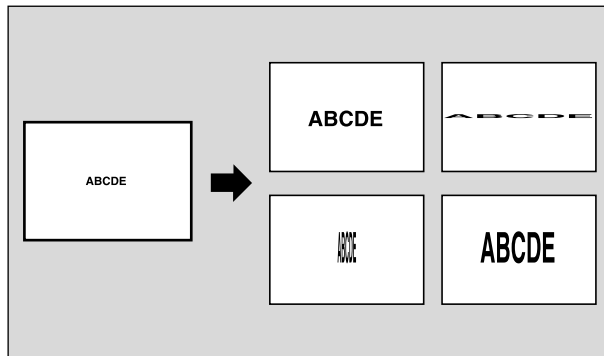

- 1 In the Basic screen, touch [Zoom].

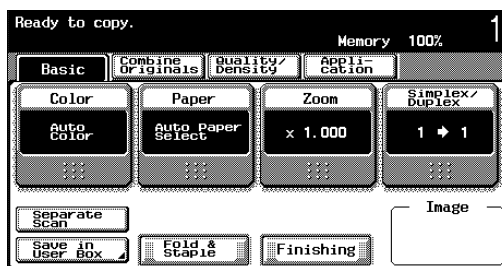

The Zoom screen appears.

- 2 Touch [XY Zoom].

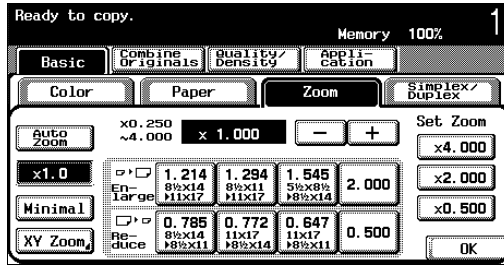

- 3 Touch [X] under “Set Individual Zoom”, and then use the keypad to type in the desired zoom ratio (between $\times 0.250$ and $\times 4.000$) for the X direction.

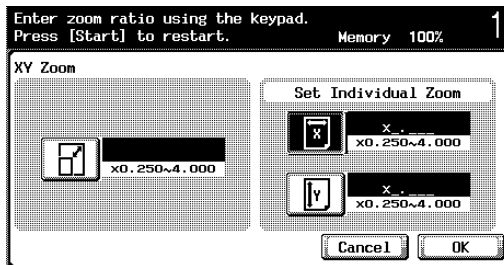

- 4 Touch [Y] under “Set Individual Zoom”, and then use the keypad to type in the desired zoom ratio (between $\times 0.250$ and $\times 4.000$) for the Y direction.

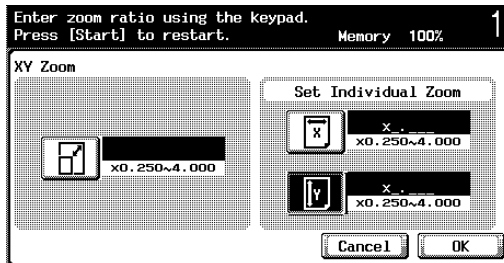

– To cancel changes to the settings, touch [Cancel].

- 5 Touch [OK], and then touch [OK] in the next screen that appears. The Basic screen appears again.

Selecting a stored zoom ratio

Copy zoom ratios that have been stored can be recalled to be used when desired. In addition, stored copy zoom ratios can be changed.

- ✓ The default setting is “×1.0”.
- ✓ Touch [+] to enlarge the zoom ratio, and touch [-] to reduce the zoom ratio in × 0.001 increments.
- ✓ Stored zoom ratios can be changed to desired zoom ratios. For details on storing zoom ratios, refer to “Storing the desired zoom ratio” on page 3-47.

- 1 In the Basic screen, touch [Zoom].

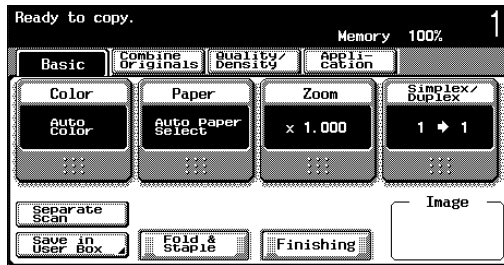

The Zoom screen appears.

- 2 Touch the button for the desired zoom ratio.

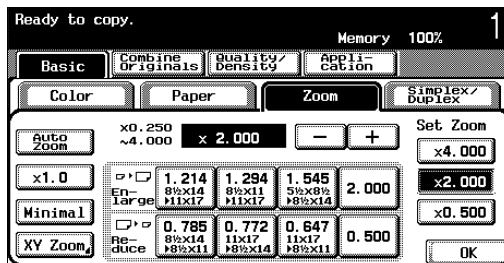

- 3 Touch [OK].

The Basic screen appears again.

Storing the desired zoom ratio

Three frequently used zoom ratios and the zoom ratio for the “Minimal” setting can be stored.

- ✓ If a value outside of the allowable range is specified, the message “Input Error” appears. Type in a value within the allowable range. If the value was incorrectly entered, press the [C] (clear) key to erase the value, and then specify the correct value.
- ✓ The default zoom ratios (×4.000, ×2.000 and ×0.500) are stored. When a new zoom ratio is stored, it overwrites the zoom ratio stored with the selected button.
- ✓ To store a “Minimal” zoom ratio, type in the desired zoom ratio between ×0.900 and ×0.999.

- 1 In the Basic screen, touch [Zoom].

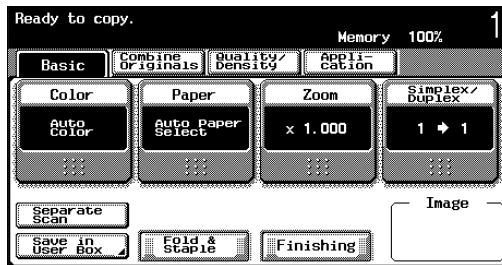

The Zoom screen appears.

- 2 Touch [XY Zoom].

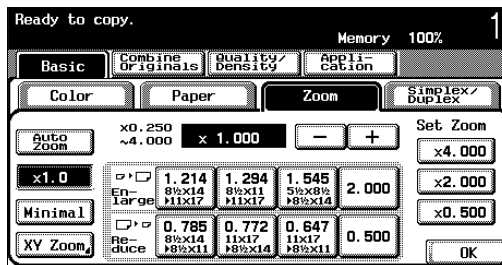

- 3 Use the keypad to type in the desired zoom ratio (between $\times 0.250$ and $\times 4.000$).

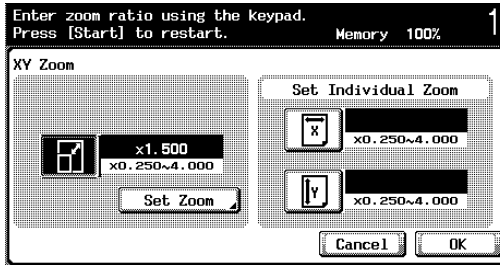

- To cancel changes to the settings, touch [Cancel].

- 4 Touch [Set Zoom].
- 5 Touch the button or [Minimal] where the new zoom ratio is to be stored.

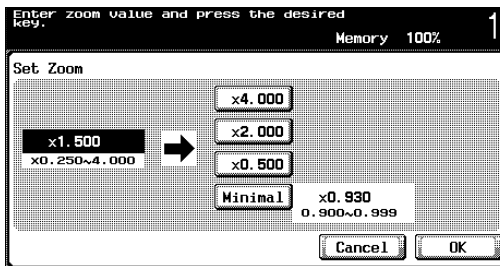

- To cancel changes to the settings, touch [Cancel].
The specified zoom ratio is stored.

- 6 Touch [OK], and then touch [OK] in the next two screens that appear.
The Basic screen appears again.

3.8 Selecting the document and copy type settings (Simplex/Duplex settings)

The type of document and copy can be specified.

The following four Simplex/Duplex settings are available.

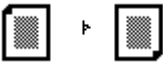
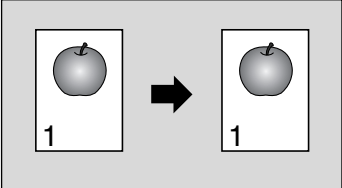
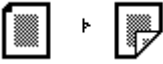
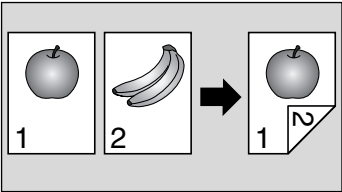
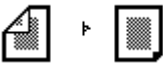
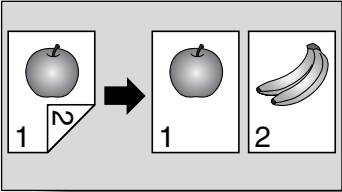
Simplex/Duplex	Description
<p>1→1</p> 	<p>Select this setting to produce single-sided copies from single-sided documents.</p> 
<p>1→2</p> 	<p>Select this setting to produce one double-sided copy from two single-sided documents.</p> 
<p>2→1</p> 	<p>Select this setting to produce two single-sided copies from one double-sided document.</p> 

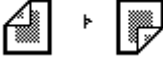
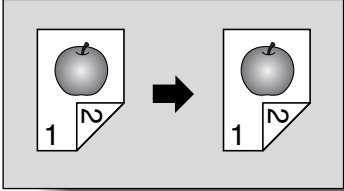
Simplex/Duplex	Description
<p data-bbox="194 172 236 193">2→2</p> 	<p data-bbox="549 172 972 213">Select this setting to produce double-sided copies from double-sided documents.</p> 

The following procedures describe how to select a Simplex/Duplex setting.



...

Note

Double-sided copying is possible only if automatic duplex unit is installed.

To select single-sided copies

- ✓ The default setting is “1→1”.
- ✓ For details on using the original glass to scan multiple document pages, refer to “Scanning a multi-page document from the original glass” on page 3-15.

- 1 In the Basic screen, touch [Simplex/Duplex].

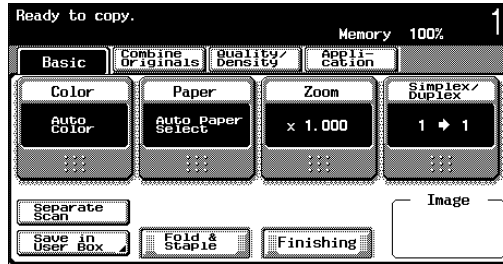

The Simplex/Duplex screen appears.

- 2 Touch [1→1] or [2→1].

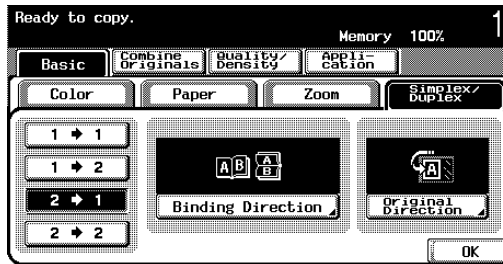

- If “2→1” is selected, specify the binding direction and the original direction, otherwise the copies will not be printed as desired.
- If the binding position for the document is set to “Auto”, the position of the binding margin is automatically selected. A binding margin along the long side of the paper is selected if the document length is 11-3/4 inch or less. If the document length is more than 11-3/4 inch, a binding margin along the short side of the paper is selected.
- If the binding position for the document is set to “Auto”, the binding margin is set at the top or at the left.
- The screens that appear differ depending on the options that are installed.

- For a double-sided document, touch [Binding Direction], select the binding position for the document, and then touch [OK].

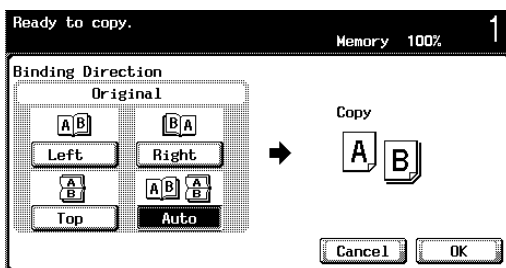

- 3 Touch [Original Direction], select the orientation of the loaded document, and then touch [OK].
 - For details on specifying the document orientation, refer to “Selecting the document orientation (Original Direction settings)” on page 3-24.
- 4 Touch [OK].
The Basic screen appears again.

To select double-sided copies

- ✓ The default setting is “1→1”.
- ✓ For details on using the original glass to scan multiple document pages, refer to “Scanning a multi-page document from the original glass” on page 3-15.

- 1 In the Basic screen, touch [Simplex/Duplex].

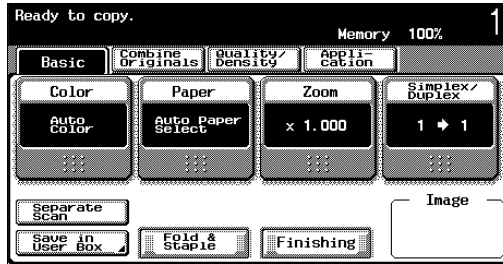

The Simplex/Duplex screen appears.

- 2 Touch [1→2] or [2→2].

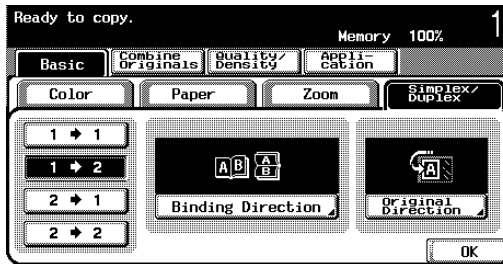

- Specify the binding direction and the original direction, otherwise the copies will not be printed as desired.
- If the binding position for the document is set to “Auto”, the position of the binding margin is automatically selected. A binding margin along the long side of the paper is selected if the document length is 11-3/4 inch or less. If the document length is more than 11-3/4 inch, a binding margin along the short side of the paper is selected.
- If the binding position for the document is set to “Auto”, the binding margin is set at the top or at the left.

- If the binding position for the copy is set to “Auto”, the binding position is automatically determined according to the orientation of the loaded document. If the document length is 11-3/4 inch or less, a binding position along the long side of the paper is selected. If the document length is more than 11-3/4 inch, a binding position along the short side of the paper is selected.
- If the binding position for the copy is set to “Auto”, the binding position is set at the top or at the left.

3 Touch [Binding Direction].

- For a single-sided document, select the binding position for the copy, and then touch [OK].

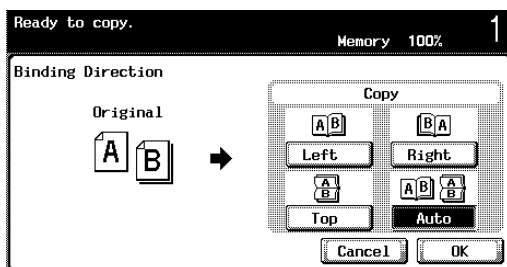

- For a double-sided document, select the binding positions for the document and the copy, and then touch [OK].

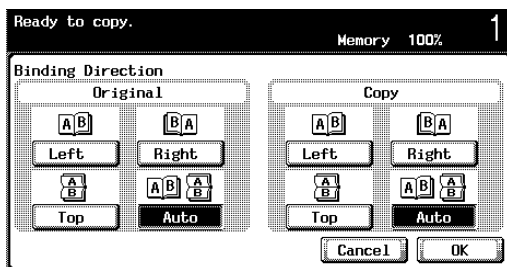

4 Touch [Original Direction], select the orientation of the loaded document, and then touch [OK].

- For details on specifying the document orientation, refer to “Selecting the document orientation (Original Direction settings)” on page 3-24.

5 Touch [OK].

The Basic screen appears again.

3.9 Selecting the quality of the document

Loading documents with small print or photos (Original Type settings)







Select the setting for the text and image type of the document to better adjust the copy quality.





The Original Type settings are available.



Note

The default setting is "Printed Photo" in the "Text/Photo" category.

Icon		Description
	Text	Select this setting when copying documents containing only text. The edges of copied text are reproduced with sharpness, providing an image that is easy to read.
		Select this setting when copying photos from documents containing both text and images onto photographic paper. A smooth copy image is produced.
		Select this setting when copying printed documents containing both text and images, such as pamphlets or catalogs.
		Select this setting when copying photos from documents onto photographic paper. Select this setting to produce better reproductions of half-tone document images (photographs, etc.) that cannot be reproduced with the usual settings. A smooth copy image is produced.
		Select this setting when copying printed documents, such as pamphlets or catalogs. Select this setting to produce better reproductions of half-tone document images (photographs, etc.) that cannot be reproduced with the usual settings.

Icon		Description
 Special Quality	 Map	Select this setting when copying documents with a background color or documents containing pencil markings or fine colored lines. A sharp copy image is produced.
	 Dot Matrix Original	Select this setting when copying documents consisting only of text that appears faint (such as that written with a pencil). The copied text is reproduced so that it is darker, providing text that is easy to read.
	 Copied Paper	Select this setting when copying images (documents) printed with this machine.

The following procedure describes how to select an Original Type setting.

To specify an original type setting

- ✓ For details on positioning the document, refer to “Feeding the document” on page 3-7.

- 1 Position the document to be copied.
- 2 In the Basic screen, touch [Quality/Density].

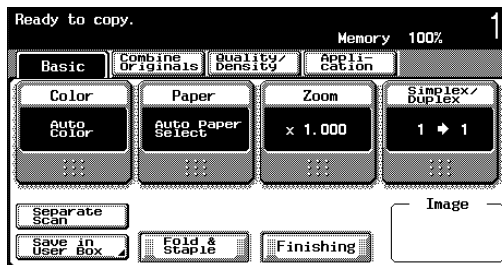

The Quality/Density screen appears.

- 3 Touch the button for the quality setting most appropriate for the loaded document.
- For a document that contains only text, touch [Text].

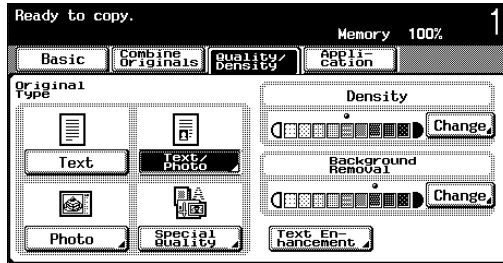

- For a document that contains both text and photos, touch [Text/Photo] to display the Photo Type screen. Touch the button for the appropriate setting, and then touch [OK].
- To cancel changes to the settings, touch [Cancel].

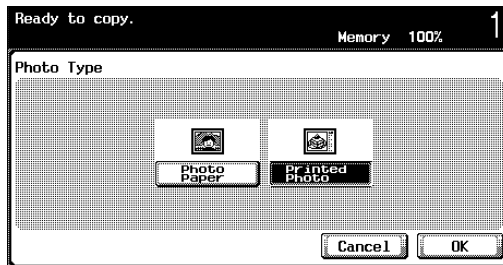

- For a document that contains photos, touch [Photo] to display the Photo Type screen. Touch the button for the appropriate setting, and then touch [OK].

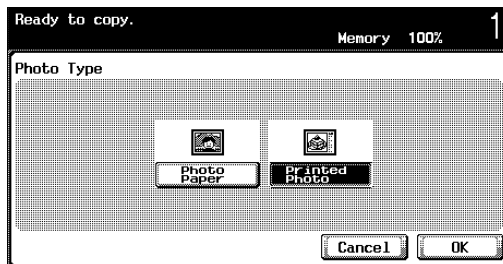

- For a document that contains maps or faint text, touch [Special Quality] to display the Special Quality screen. Touch the button for the appropriate setting, and then touch [OK].

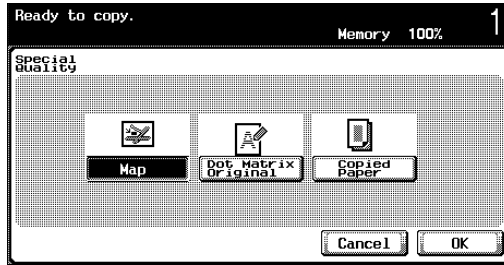

The Quality/Density screen appears again.

3.10 Specifying the density settings

The density can be adjusted to print a copy that is darker or lighter than the current print result.

The following three density adjustments are available.

Density Settings	Description
Density	The density of the print image can be adjusted to one of nine levels. Each time [Light] or [Dark] is touched, the density is lightened or darkened by one level. Touch [Std.] to select the middle setting of the nine levels.
Background Removal	The density of the background color of the document can be adjusted to one of nine levels. Each time [Light] or [Dark] is touched, the background density is lightened or darkened by one level. Touch [Std.] to select the seventh setting from the "Light" end. Touch [Auto] to automatically adjust the level of the background density according to the document being copied.
Text Enhancement	Select one of nine settings for the reproduction quality of text when copying documents consisting of text that overlaps images such as illustrations or graphs (text with a background). Each time [Lighter Text] or [Darker Text] is touched, the text density is lightened or darkened by one level. To emphasize the text on the background, touch [Darker Text] to adjust the setting toward +. To de-emphasize the text on the background, touch [Lighter Text] to adjust the setting toward -. Touch [Std.] to select the middle setting of the nine levels.

The following procedures describe how to specify the density settings.

Adjusting the print density (Density settings)

- 1 In the Basic screen, touch [Quality/Density].

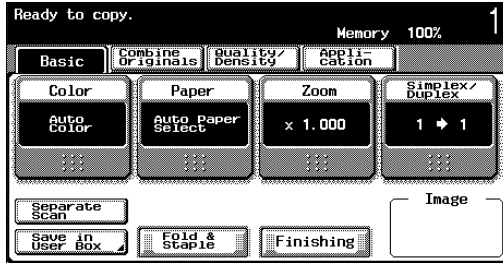

The Quality/Density screen appears.

- 2 Touch [Change] under “Density”.

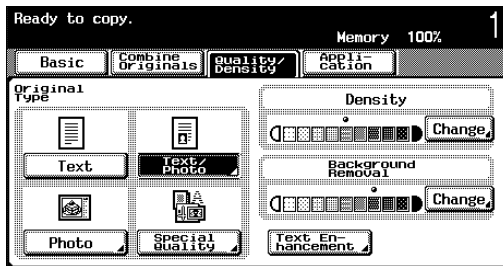

The Density screen appears.

- 3 Select the desired Density setting.

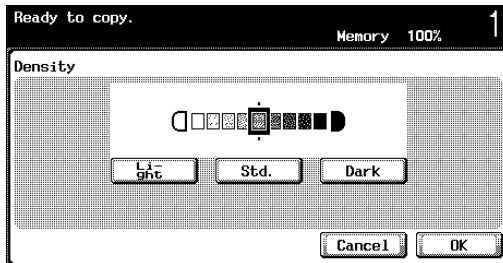

- Each time [Light] or [Dark] is touched, the density is lightened or darkened by one level.
- To select the center setting (default setting), touch [Std.].
- To cancel changes to the settings, touch [Cancel].

- 4 Touch [OK].

Adjusting the background density (Background Removal settings)

- 1 In the Basic screen, touch [Quality/Density].

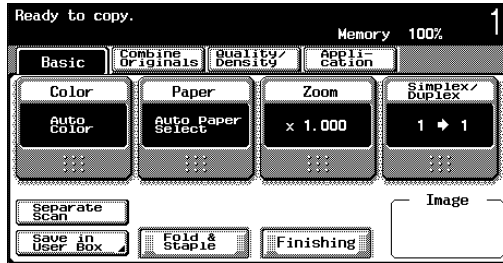

The Quality/Density screen appears.

- 2 Touch [Change] under “Background Removal”.

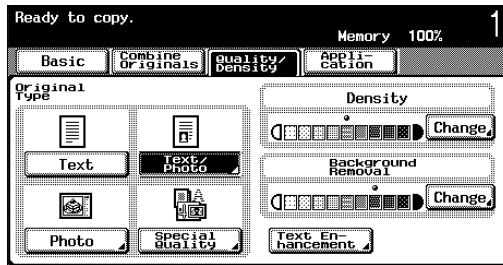

The Background Removal screen appears.

- 3 Select the desired background density setting.

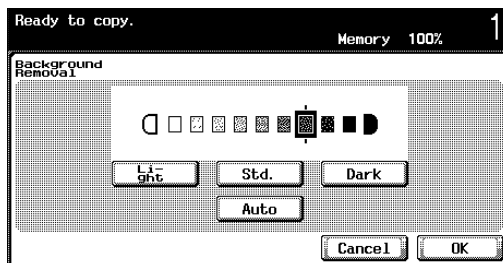

- Each time [Light] or [Dark] is touched, the density is lightened or darkened by one level.
- To select the third setting from the right (default setting), touch [Std.].

- Touch [Auto] to automatically adjust the level of the background density according to the document being copied.
- To cancel changes to the settings, touch [Cancel].

4 Touch [OK].

Adjusting the reproduction quality of text

- ✓ The default setting is “0”.

- 1 In the Basic screen, touch [Quality/Density].

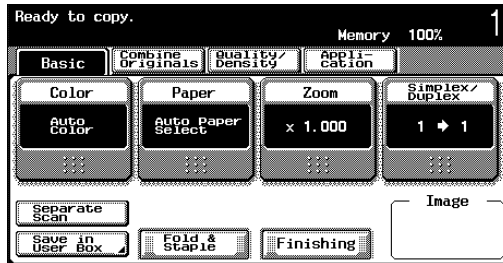

The Quality/Density screen appears.

- 2 Touch [Text Enhancement].

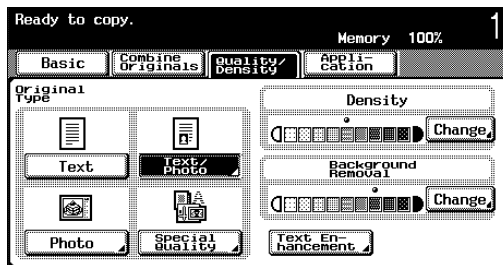

The Text Enhancement screen appears.

- 3 Select the desired text density setting.

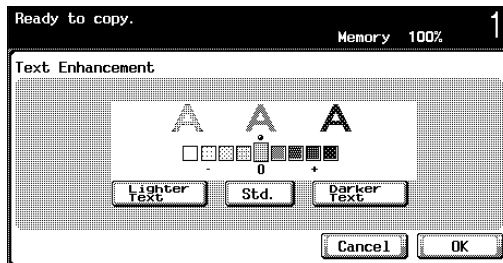

- Each time [Lighter Text] or [Darker Text] is touched, the density is lightened or darkened by one level.
- Touch [Std.] to select the middle setting (“0”) of the nine levels.
- To cancel changes to the settings, touch [Cancel].

- 4 Touch [OK].

3.11 Selecting a combine originals setting

Document images of multiple pages (2, 4 or 8 pages) can be combined and printed on a single page, reducing paper use.



Detail

When a Combine Originals setting is selected, the auto display zoom ratio is selected, and the document image is copied at a reduced size.

The auto display zoom ratios for each setting are listed below.

2 in 1: x0.647

4 in 1: x0.500

8 in 1: x0.323



Note

The default setting is the Auto Display Zoom Ratio.

By using the "Auto Zoom for Combine/Booklet" parameter in Utility mode, the machine can be set so that the auto display zoom ratios are not recalled. For details, refer to "Copier setting" on page 12-22.

The following three Combine Originals settings are available.

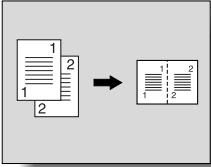
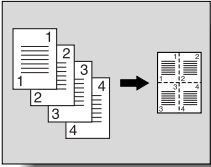
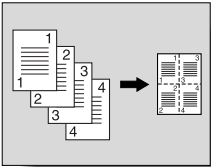
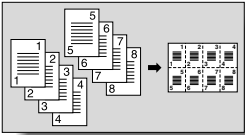
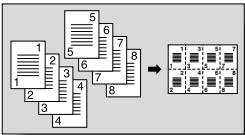
Combine Originals Setting	Description
2 in 1	<p>Select this setting to print two document pages on one page.</p> 
4 in 1	<p>Select this setting to print four document pages on one page. The page arrangement (Numbering Direction settings) can be specified.</p> <p><Horizontal></p>  <p><Vertical></p> 
8 in 1	<p>Select this setting to print eight document pages on one page. The page arrangement (Numbering Direction settings) can be specified.</p> <p><Horizontal></p>  <p><Vertical></p> 

The following procedure describes how to select a Combine Originals setting.

Copying multiple document pages onto a single page (Combine Originals)

- 1 In the Basic screen, touch [Combine Originals].

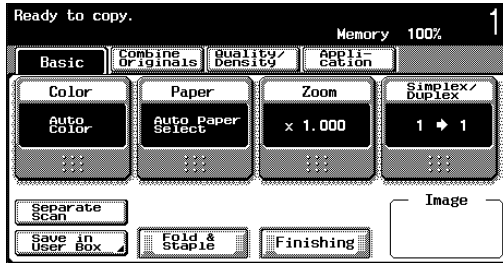

The Combine Originals and Original settings screen appears.

- 2 Select the desired combination of pages.

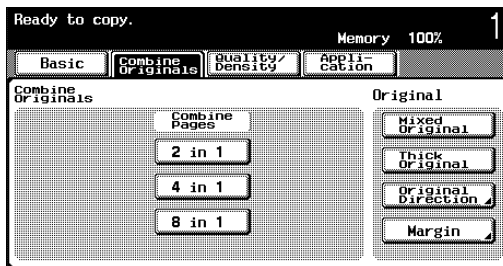

- Select the page arrangement according to the orientation and number of pages. If “4 in 1” or “8 in 1” was selected, the page arrangement for “Vertical” and “Horizontal” can be viewed in the sub display area. However, this appears only if the “Sub Screen Display Type” parameter in Utility mode is set to “Setting value”.
- If “4 in 1” or “8 in 1” was selected, touch [Horizontal] or [Vertical] to specify the page arrangement.

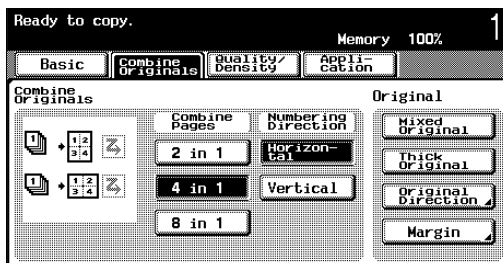

- To cancel the setting, touch the button again to deselect it.

3.12 Selecting finishing settings

Various settings are available for sorting and finishing copies when they are fed into the copy exit tray.



Note



The factory default setting is “Group”.



Detail

If no finisher is installed and the following conditions are met, printed copies can be fed out and sorted in an alternating crisscross pattern.

8-1/2 × 11- or 5-1/2 × 8-1/2-size paper is used.

Paper of the same size and type is loaded with the  orientation in one paper tray and with the  orientation in another tray.

The “Auto Paper Select” setting is selected.

The “Auto Paper Select” setting is not selected when the “Mixed Original” setting is selected.



Note

From Administrator mode, the machine can be set so that copies are fed out without being shifted when the finisher FS-514 is installed. As a factory default, “Offset by Each Job Setting” is set to “ON”. For details on specifying the setting for offset feeding when the finisher FS-514 is installed, refer to “System setting” on page 12-27.

The following five Finishing settings are available.

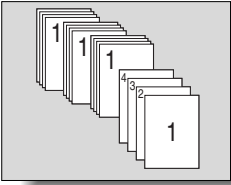
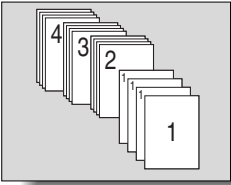
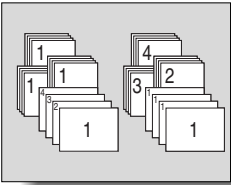
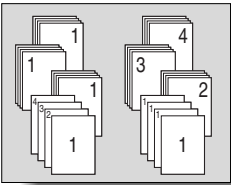
Finishing Setting	Description
Sort	<p>Select this setting to separate each set of a multi-page document (collated).</p> 
Group	<p>Select this setting to separate the copies of each page in a multi-page document (uncollated).</p> 
Offset	<p><If no finisher is installed> If the sorting conditions are met, printed copies are fed out and sorted in an alternating crisscross pattern.</p> 
	<p><If a finisher is installed> The copies are fed out and stacked on top of each other with each set shifted to separate it.</p> 

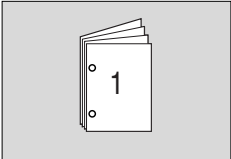
Finishing Setting	Description
Staple	Select one of these settings to bind the copies with a staple in the corner or with two staples. <div data-bbox="647 233 878 392" style="text-align: center;">  </div>
Punch	Select this setting to punch holes (2 or 3) in the copies for filing them. <div data-bbox="647 501 878 660" style="text-align: center;">  </div>

The following procedures describe how to select Finishing settings.





Note

The Staple settings and Punch settings differ depending on the installed finisher.

Available Staple and Punch settings

	Finisher FS-514	Finisher FS-603	Finisher FS-501
Staple settings “Corner” & “2 Position”	○	○	—
Staple setting “Corner”	○	○	○
Punch setting	With punch kit PK-510 installed ○	With punch kit PK-501 installed ○	—

Separating copies by sets (“Sort” setting)

- ✓ The factory default setting is “Group”.
- ✓ If “Offset” is selected while no finisher is installed, printed copies will be fed out and sorted in an alternating crisscross pattern if the following conditions are met.
 - ✓ 8-1/2 × 11- or 5-1/2 × 8-1/2-size paper is used.
 - ✓ Paper of the same size and type is loaded with the  orientation in one paper tray and with the  orientation in another tray.
 - ✓ The “Auto Paper Select” setting is selected.
 - ✓ The “Auto Paper Select” setting is not selected when the “Mixed Original” setting is selected.
- ✓ If “Offset” is selected while a finisher is installed, printed copies are fed out and stacked on top of each other with each set shifted to separate it.

- 1 In the Basic screen, touch [Finishing].

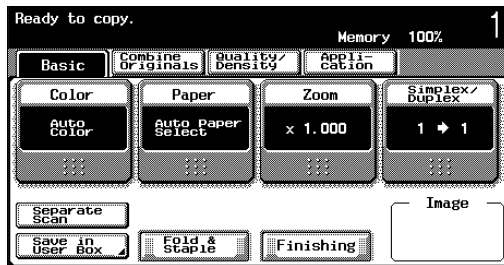

The Finishing screen appears.

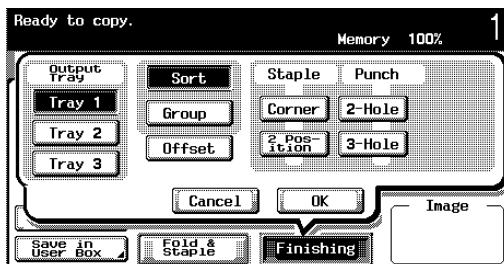

- 2 Touch [Sort].
 - To separate each set of copies, touch [Offset].
 - To specify the output tray, touch the button for the desired tray under “Output Tray”.



- 3 Touch [OK].

The Basic screen appears again.

Separating copies by pages (“Group” setting)

- ✓ The default setting is “Group”.
- ✓ If “Offset” is selected while no finisher is installed, printed copies will be fed out and sorted in an alternating crisscross pattern if the following conditions are met.
 - ✓ 8-1/2 × 11- or 5-1/2 × 8-1/2-size paper is used.
 - ✓ Paper of the same size and type is loaded with the  orientation in one paper tray and with the  orientation in another tray.
 - ✓ The “Auto Paper Select” setting is selected.
 - ✓ The “Auto Paper Select” setting is not selected when the “Mixed Original” setting is selected.
- ✓ If “Offset” is selected while a finisher is installed, printed copies are fed out and stacked on top of each other with each set shifted to separate it.

- 1 In the Basic screen, touch [Finishing].

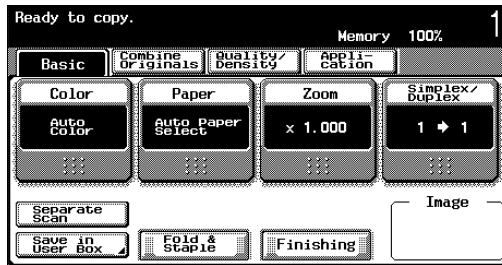

The Finishing screen appears.

- 2 Touch [Group].
 - To separate each set of pages, touch [Offset].
 - To specify the output tray, touch the button for the desired tray under “Output Tray”.

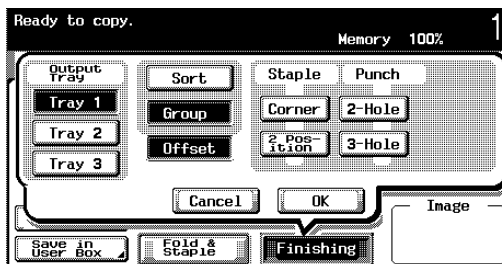









- 3 Touch [OK].

The Basic screen appears again.

Stapling tray copies (Staple settings)

Copies can be fed out stapled either in the corner or at two places.

When Finisher FS-514 is installed

Tray	Paper Weight	Paper Size	Loading Capacity
Finishing tray 1	16 lb to 24 lb	11 × 17  to 8-1/2 × 11 	1-1/4 inch
	24-1/4 lb to 32 lb		
Finishing tray 2	16 lb to 24 lb	11 × 17  to 8-1/2 × 11 	A4  or less: 5-1/4 inch B4  or more: 2-1/2 inch
	24-1/4 lb to 32 lb		
Optional finishing tray	16 lb to 24 lb	11 × 17  to 8-1/2 × 11 	1 inch
	24-1/4 lb to 32 lb		

Examples of the possible number of bound pages

- 50 sheets of 24 lb paper
- 2 sheets of 55-1/2 lb paper + 48 sheets of 24 lb paper
- Maximum of 30 sheets of 24-1/4 to 40 lb paper



Detail

In order for the copies to be stapled, all of the following conditions must be met.

The paper width must be between 7-1/4 inch and 11-3/4 inch.

The paper length must be between 5-3/4 inch and 17 inch.

If the “Mixed Original” setting is selected, all copies must have the same paper width.





If a Staple setting is selected, the “Sort” setting is automatically selected.



A Staple setting cannot be used together with the “Offset” setting.

If a Staple setting is to be selected, select the orientation in which the original is positioned and the orientation of the page to be stapled, otherwise the copies may not be stapled as desired.







For details on specifying the original orientation, refer to “Selecting the document orientation (Original Direction settings)” on page 3-24.

When Finisher FS-603 is installed

Paper Weight	Paper Size	Loading Capacity (detected with either measurement)	
16 lb to 24 lb	8-1/2 × 11  / 	1,000 sheets	6 in.
	11 × 17  , 8-1/2 × 14 	500 sheets	3 in.

	Number of Bound Pages	Maximum Number of Sets		
		One place towards the back	One place towards the front	Two places
8-1/2 × 11  or smaller	2 sheets	100 sets	40 sets	40 sets
	3 to 5 sheets	80 sets	40 sets	40 sets
	6 to 10 sheets	60 sets	40 sets	40 sets
	11 to 20 sheets	30 sets	30 sets	30 sets
	21 to 30 sheets	30 sets	30 sets	30 sets
	31 to 50 sheets	30 sets/1,000 sheets	30 sets/1,000 sheets	30 sets/1,000 sheets
8-1/2 × 14  or larger	2 sheets	100 sets	50 sets	50 sets
	3 to 5 sheets	80 sets	40 sets	40 sets
	6 to 10 sheets	40 sets	40 sets	40 sets
	11 to 20 sheets	30 sets/1,000 sheets	30 sets/1,000 sheets	30 sets/1,000 sheets
	21 to 25 sheets	30 sets/1,000 sheets	30 sets/1,000 sheets	30 sets/1,000 sheets

When Finisher FS-501 is installed

Paper Weight	Paper Size	Loading Capacity (detected with either measurement)	
16 lb to 24 lb	8-1/2 × 11  / 	1,000 sheets	6 in.
	7-1/4 × 10-1/2  / 	500 sheets	3 in.
	11 × 17  , 8-1/2 × 14 	500 sheets	3 in.

Number of Bound Pages	Maximum Number of Sets	
2 sheets	100 sets	200 sheets
3 to 5 sheets	80 sets	400 sheets
6 to 10 sheets	60 sets	600 sheets
11 to 20 sheets	40 sets	800 sheets
21 to 30 sheets	33 sets	1,000 sheets

**Detail**

In order for the copies to be stapled, all of the following conditions must be met.

The paper width must be between 7-1/4 in. and 11-3/4 in..

The paper length must be between 7-1/4 in. and 17 in..

If the "Mixed Original" setting is selected, all copies must have the same paper width.

If a Staple setting is selected, the "Sort" setting is automatically selected.

A Staple setting cannot be used together with the "Offset" setting.

If a Staple setting is to be selected, select the orientation in which the document is positioned and the orientation of the page to be stapled, otherwise the copies may not be stapled as desired.

For details on specifying the document orientation, refer to "Selecting the document orientation (Original Direction settings)" on page 3-24.

To bind copies with staples

- 1 In the Basic screen, touch [Finishing].

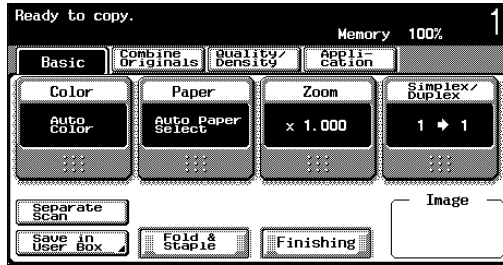

The Finishing screen appears.

- 2 Under “Staple”, touch either [Corner] or [2 Position].

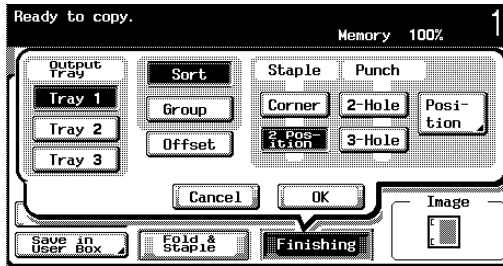

- To cancel the Staple settings, touch [Corner] or [2 Position] again to deselect it. [2 Position] is available only if finisher FS-514 or finisher FS-603 is installed.
- To cancel changes to the settings, touch [Cancel].
- To specify the output tray, touch the button for desired tray under “Output Tray”.

- 3 Touch [Position], and then touch the button for the desired position.

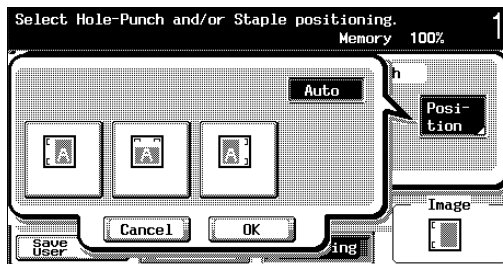

- Touch [Auto] to automatically determine the stapling position according to the orientation of the loaded document. If the document length is 11-11/16 or less, the long side of the paper is stapled. If the document length is more than 11-11/16, the short side of the paper is stapled.
- If "Auto" is selected, the stapling position is set at the top or at the left.
- To cancel changes to the stapling position, touch [Cancel].

- 4 Touch [OK], and then touch [OK] in the next screen that appears. The Basic screen appears again.

Punching holes in copies (Punch settings)



Detail

In order for holes to be punched in the copies, all of the following conditions must be met.

The paper width must be 8-1/2 in. or between 11 in. and 11-3/4 in. (with the “2-Hole” punch setting).

The paper width must be between 11 in. and 11-3/4 in. (with the “3-Hole” punch setting).

The paper length must be between 7-1/4 in. and 17 in.

If the “Mixed Original” setting is selected, all copies must have the same paper width.

If a Punch setting is to be selected, select the orientation in which the document is positioned. If an Original Direction setting is not selected, holes may not be punched in the copies as desired.

For details on specifying the document orientation, refer to “Selecting the document orientation (Original Direction settings)” on page 3-24.



Note

Holes can be punched in the paper that is fed out if punch kit PK-510 is installed on optional finisher FS-514 or punch kit PK-501 is installed on optional finisher FS-603.

Paper Weight	Paper Size
16 lb to 55-1/2 lb	2-hole: 11 × 17 to 8-1/2 × 11 3-hole: 11 × 17 , 8-1/2 × 11

To punch holes in copies

- 1 In the Basic screen, touch [Finishing].

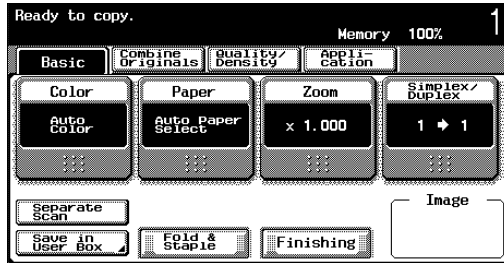

The Finishing screen appears.

- 2 Touch [2-Hole] or [3-Hole].

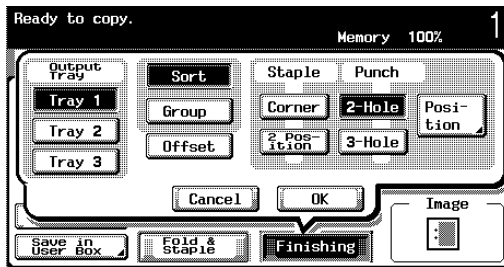

- To cancel the Punch setting, touch [2-Hole] or [3-Hole] again to deselect it.
- To cancel changes to the settings, touch [Cancel].
- To specify the output tray, touch the button for the desired tray under "Output Tray".

- 3 Touch [Position], and then touch the button for the desired position.

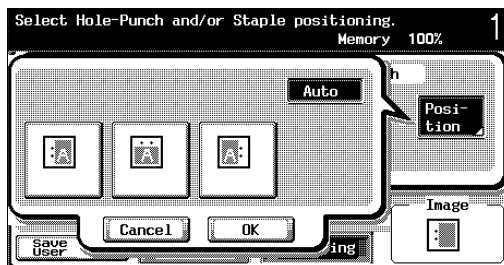

- Touch [Auto] to automatically determine the position of the punched holes according to the orientation of the loaded document. If the document length is 11-11/16 in. or less, the holes are punched along the long side of the paper. If the document length is more than 11-11/16 in., the holes are punched along the short side of the paper.
- If "Auto" is selected, the punched hole position is set at the top or at the left.
- To cancel changes to the punched hole position, touch [Cancel].



- 4** Touch [OK], and then touch [OK] in the next screen that appears. The Basic screen appears again.

3.13 Specifying center binding

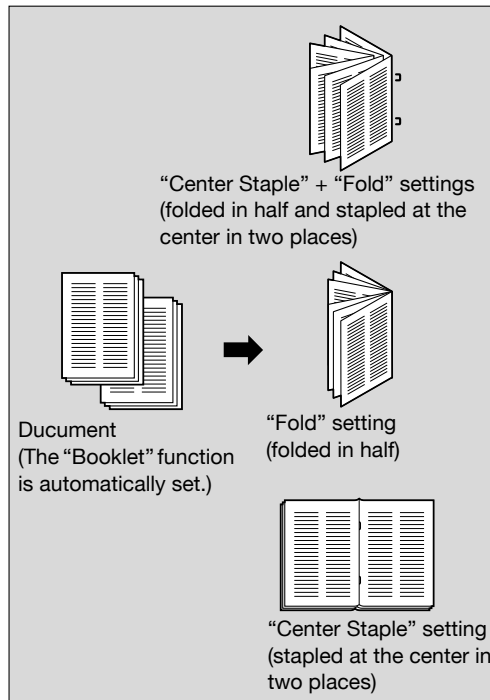
The paper that is fed out can be folded in half and stapled at two places along the vertical center.



When Finisher FS-514 is installed

Paper Weight	Paper Size	Loading Capacity (detected in either measurement)
13-1/4 lb to 24 lb	8-1/2 × 11  , 11 × 17 	200 sheets or 20 sets
24-1/4 lb to 55-1/2 lb		—

Examples of the possible number of bound pages

- 2 to 15 sheets of 24 lb paper (maximum of 60 pages)
- 1 sheet of 13-1/4 to 55-1/2 lb paper + 14 sheets of 13-1/4 to 24 lb paper (maximum of 60 pages)
- Maximum of 13 sheets of 24-1/4 to 32 lb paper
- Maximum of 10 sheets of 32-1/4 to 40 lb paper
- Maximum of 8 sheets of 40-1/4 to 55-1/2 lb paper



**Detail**

In order for copies to be bound at the center or folded in half, all of the following conditions must be met.

The paper width must be between 7-1/4 inch and 11-3/4 inch.

The paper length must be between 10 inch and 17 inch.

When Finisher FS-603 is installed

Paper Weight	Paper Size	Number of Bound Pages
16 lb to 24 lb	8-1/2 × 11  , 11 × 17 	2 sheets to 15 sheets*

Number of Bound Pages	Maximum Number of Sets
2 sheets to 5 sheets	20 sets
6 sheets to 10 sheets	10 sets
11 sheets to 15 sheets*	10 sets

* The number of sheets that can be bound together differs depending on the paper weight.
 17 lb paper: 15 sheets
 21-1/4 lb paper: 10 sheets

**Detail**

In order for copies to be bound at the center, all of the following conditions must be met.

The paper width must be between 8-1/4 inch and 11-3/4 inch.

The paper length must be between 11 inch and 17 inch.



...

Note

The “Fold & Staple” setting is available when the saddle stitcher is installed on optional finisher FS-514 or if finisher FS-603 is installed. The “Fold” setting is available when the saddle stitcher is installed on optional finisher FS-514.

To bind copies at the center (“Fold & Staple”): Finisher FS-514

- ✓ When the “Fold & Staple” setting is selected, the following default settings are automatically selected.
 - “1→2”, “Sort”, “Booklet”,
 - Auto display zoom ratio when a Booklet setting is selected (×0.647)

- 1 In the Basic screen, touch [Fold & Staple].

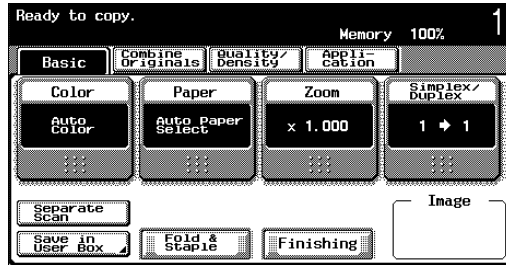

The Center Erase screen appears.

- 2 Specify the desired center binding and folding settings.
 - To staple copies at the center in two places, touch [Center Staple].
 - To fold copies in half, touch [Fold].
 - To fold copies in half and staple them at the center in two places, touch [Center Staple] and [Fold].

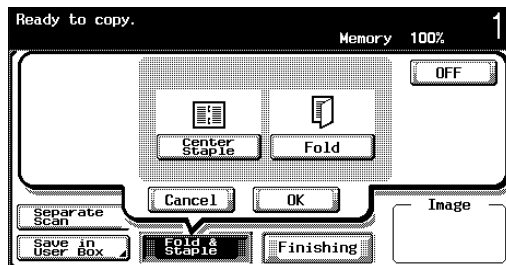

- To cancel the “Fold & Staple” setting, touch [OFF].
- To cancel changes to the settings, touch [Cancel].

- 3 Touch [OK].

The Basic screen appears again.

To bind copies at the center (“Fold & Staple”): Finisher FS-603

- ✓ When the “Fold & Staple” setting is selected, the following default settings are automatically selected.
 - “1→2”, “Sort”, “Booklet”,
 - Auto display zoom ratio when a Booklet setting is selected (×0.647)
- ✓ If “Yes” is selected under “Center Erase”, an area of 3/8 in. along the binding is erased.
- ✓ If paper misfeeds often occur when “No” is selected under “Center Erase”, select “Yes” to reduce the number of paper misfeeds.

- 1 In the Basic screen, touch [Fold & Staple].

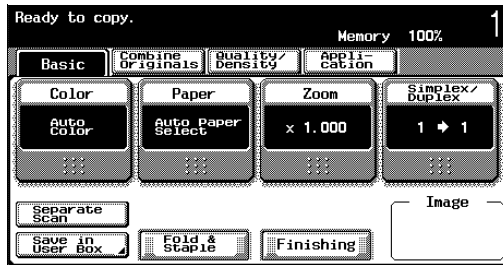

The Center Erase screen appears.

- 2 Touch the button for the desired Center Erase setting.

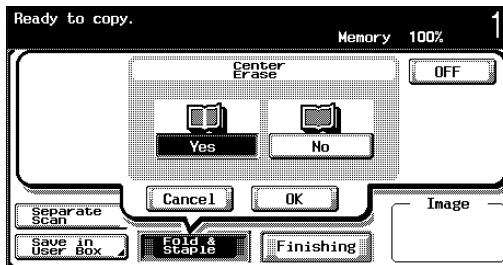

- To erase the area along the center, touch [Yes]. To not erase the area along the center, touch [No].
- To cancel the “Fold & Staple” setting, touch [OFF].
- To cancel changes to the settings, touch [Cancel].

- 3 Touch [OK].

The Basic screen appears again.

3.14 Scanning the next document to be copied while a copy job is being printed (next job reservation)

The settings for the next copy job can be specified and the document can be scanned while a copy operation is being performed so that it can be printed once the current copy operation is finished.

To reserve a copy job

- ✓ Up to 61 copy jobs, including the current copy job, can be reserved.
- ✓ A copy job can be reserved after scanning of the loaded document is finished. A copy job cannot be reserved while a document is being scanned.
- ✓ If Utility Setting parameter “Copy Operating Screen” is set to “ON”, [Program Next Job] appears. Touch [Program Next Job], and then specify the copy settings for the next copy job.
For details on specifying the “Copy Operating Screen” parameter, refer to “Display setting” on page 12-19.
- ✓ For details on positioning the document, refer to “Feeding the document” on page 3-7.
- ✓ To cancel a reserved copy job, display the Basic screen for the reserved copy job, and then press the [Stop] key. For details, refer to “Performing operations on jobs” on page 11-6.

1 Press the [Start] key to begin scanning and outputting the current copy job.

- The Basic screen for reserving a copy job appears.

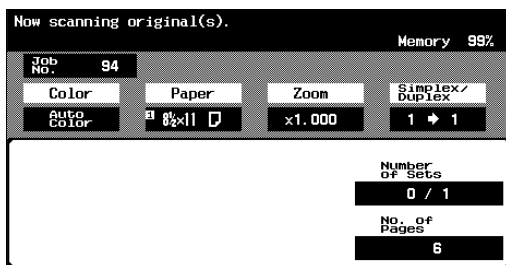

- When the message “Ready to accept another job.” appears, copy settings can be specified for the next copy job.



- Press the [Start] key.
- After the current copy job is finished, the next copy job begins.
 - When the current copy job is finished, the copy settings for the next copy job are automatically displayed and the copy operation begins.

3.15 Stopping scanning/printing

The following procedure describes how to stop scanning the document and stop the printing operation.

To stop scanning/printing

- ✓ If a document is being scanned for a job, pressing the [Stop] key stops scanning.
- ✓ For details on deleting a stopped job, refer to “Deleting a stopped job” on page 3-87.

- 1 Press the [Stop] key while a document is being scanned or a job is being printed.

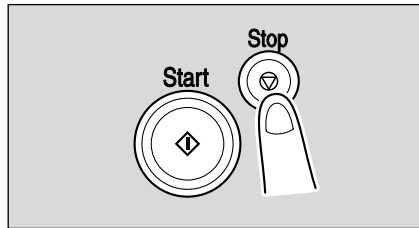

Scanning/printing stops.

The Stopped Jobs screen appears.

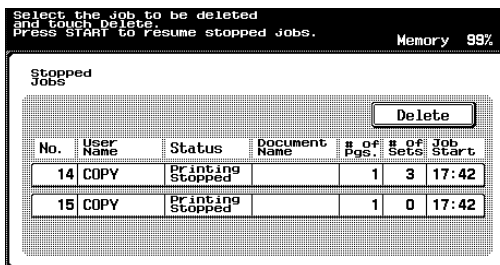

- 2 To continue all stopped jobs, press the [Start] key

3.16 Deleting a stopped job

The following procedure describes how to delete a stopped job.

To delete a stopped job

- ✓ For details on stopping a job being printed, refer to “Stopping scanning/printing” on page 3-86.
- ✓ Select only one job at a time to be deleted.
- ✓ To continue the stopped job, press the [Start] key.

- 1 Press the [Stop] key while a document is being scanned or a job is being printed.

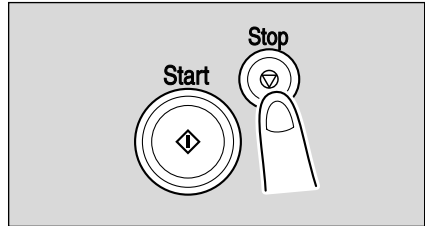

Scanning/printing stops.

The Stopped Jobs screen appears.

- 2 Select the job to be deleted, and then touch [Delete].

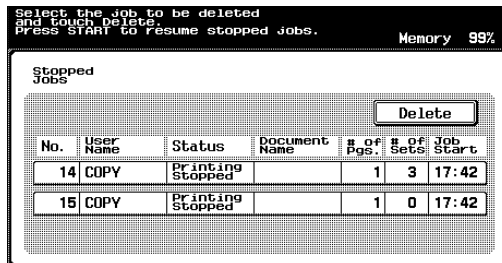

The selected job is deleted.

4

Additional copy operations

4 Additional copy operations

4.1 Checking the copy settings (Mode Check)

From the Mode Check screens, the current copy settings can be checked and changed if desired.

To check the settings

- 1 Press the [Mode Check] key.

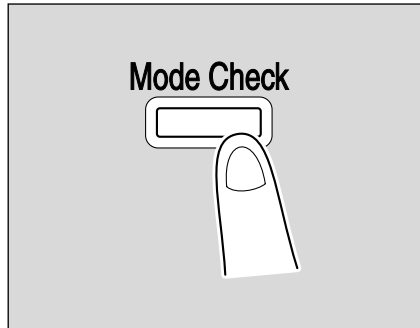

The Mode Check screen appears.

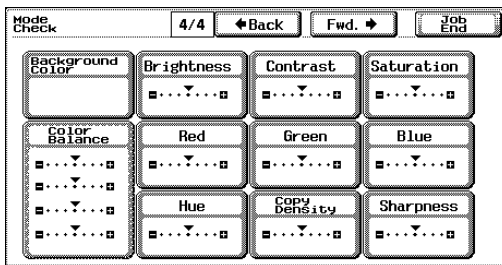
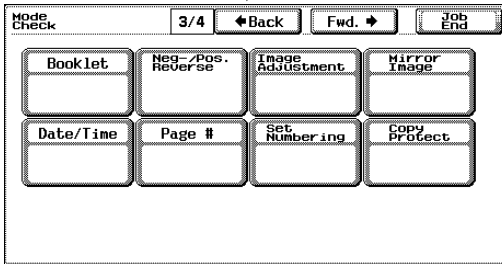
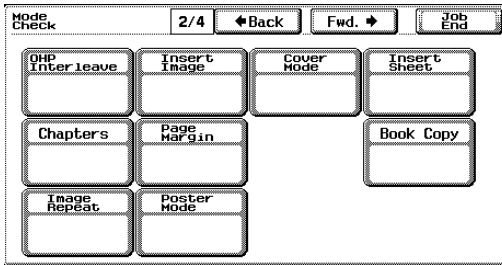
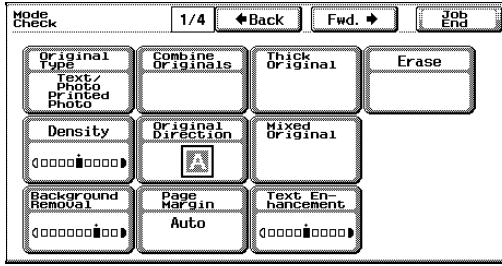

- 2 After checking the settings, touch [Job End] or press the [Mode Check] key.

The Basic screen appears again.



Detail

There are four Mode Check screens. The number of the currently displayed screen appears to the right of the screen title.

To display the previous screen, touch [←Back]. To display the next screen, touch [Fwd.→].

The buttons for functions where the setting has been changed from the default appear selected.

To change the settings

- 1 Press the [Mode Check] key.
- 2 Touch [←Back] or [Fwd.→] until the button for the function to be changed is displayed.
- 3 Touch the button for the setting that you wish to change.
The screen for specifying the setting appears.
- 4 Follow the appropriate procedure to change the setting.

4.2 Printing a proof copy to be checked (Proof Copy)

Before printing a large number of copies, a single proof copy can first be printed to be checked. This prevents copy errors from occurring.

To make test prints

- 1 Position the document to be copied. (Refer to page 3-7 for details.)
- 2 Select the desired copy settings.
- 3 Press the [Proof Copy] key.
A single proof copy is printed.

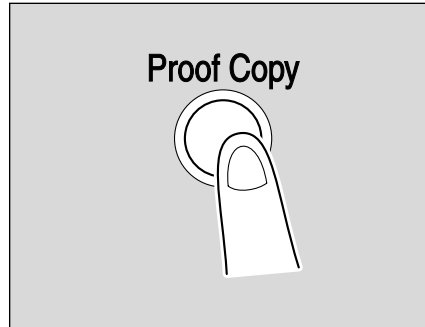

- 4 Check the sample copy.
 - If the sample copy was printed as desired, skip to step 8.
 - To change the copy settings, continue with step 5.
- 5 Touch [Change Setting] in the screen that appeared when the sample copy is printed.

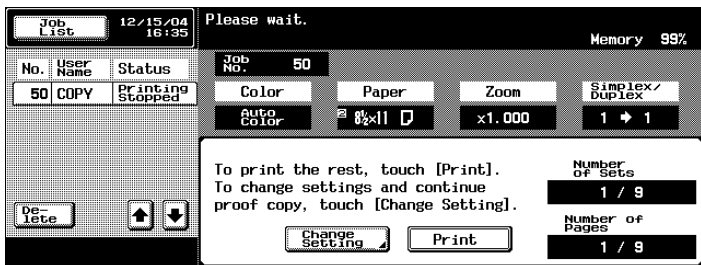

- 6 In the Change Job Setting screen, change the copy settings as desired, and then touch [OK].
- To cancel changes to the settings, touch [Cancel Change].

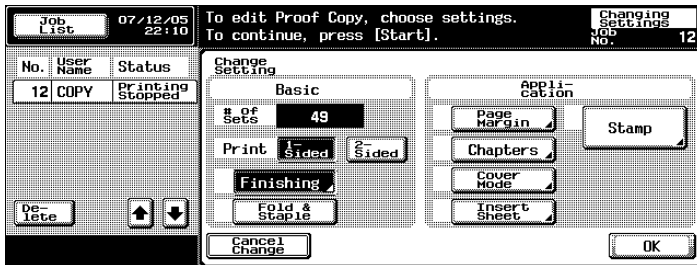

? Why is the button for the setting that I wish to change not displayed?

The copy setting cannot be changed.

- If the copy settings cannot be changed, stop printing the proof copy. Then, press the [Reset] key to cancel the copy settings, and then specify the desired settings.

- 7 Press the [Proof Copy] key to print another sample copy.
- If copying stops while the proof copy screen is displayed after the proof copy was printed, press the [Reset] key. Otherwise, from the list of jobs on the sub display area, select the proof copy job that stopped, and then touch [Delete]. In the screen that appears, requesting confirmation to delete the copy program, touch [Yes].



- If an automatic system reset operation is performed while the proof copy for a job is being checked, that job is stored in the memory.
- If the “System Auto Reset” parameter is set to “OFF”, the job is added to the Held Jobs list after no job is performed for one minute.
- To stop the proof copy while scanning or printing, perform the operation described in “Stopping scanning/printing” on page 3-86.
- If multiple copies have been specified, another sample copy can be printed.
- The number under “# of Sets” in the Change Setting screen is the number of copies that will be printed when [Print] is touched.
- The number under “Number of Sets” in the screen that appeared when a sample copy is printed indicates the number of copies that are sample copies/total number of copies specified.
- The number under “Number of Pages” in the screen that appeared when a sample copy is printed indicates the number of copies that are sample copies/the number of pages in the sample copy.

8 Touch [Print].

The remaining copies are queued as a copy job.

4.3 Interrupting a copy job (Interrupt mode)

The current jobs can be temporarily interrupted so a document can be copied with different copy settings.

This is convenient for quickly making a copy.



Detail

For details on making a copy after printing of the current job is finished, refer to "To increase priority for printing" on page 11-17.

To interrupt a copy job

1 Position the document to be copied. (For details, refer to page 3-7.)

2 Press the [Interrupt] key.

- If a job is being printed, the message "Job is stopping." appears.

The indicator on the [Interrupt] key lights up in green and printing of the current job stops.

? What settings are selected when the [Interrupt] key is pressed?

→ When the [Interrupt] key is pressed, all functions and settings are reset to their defaults.

? Why is the [Interrupt] key not available?

→ The [Interrupt] key cannot be pressed while a document is being scanned.

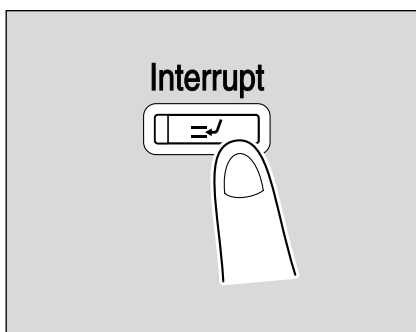

3 Select the desired copy settings.

4 Press the [Start] key.

Printing begins for the job that the previous job was interrupted for.

- 5 After the interrupting job is finished printing, press the [Interrupt] key.
The indicator on the [Interrupt] key goes off, and Interrupt mode is canceled.
The settings return to those specified before printing was interrupted.

**Note**

If the interrupting job is cancelled, printing for the interrupted job automatically restarts.

4.4 Registering copy programs (Mode Memory)

Up to 15 copy programs can be registered.

A name of up to 16 characters can be specified for the registered copy programs.

To store a copy program

- 1 Using the touch panel buttons and control panel keys, specify the copy settings to be registered in the copy program.

? Can the current settings be checked?

→ To check the currently specified copy settings, press the [Mode Check] key. For details, refer to “Checking the copy settings (Mode Check)” on page 4-2.

- 2 Press the [Mode Memory] key.

The Recall Copy Program screen appears.

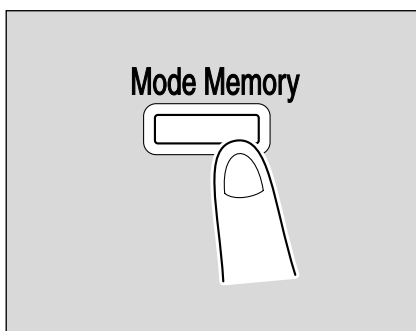

- 3 Touch [Program Registration].

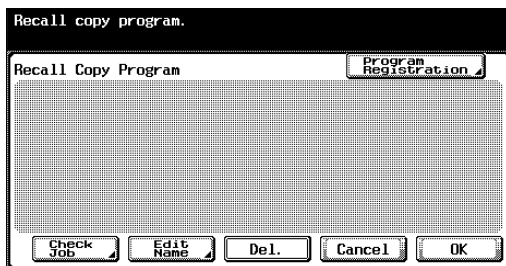

The Program Name screen appears.

? Why is [Program Registration] not available?

→ If 15 copy programs have been registered, delete an unnecessary copy program. For details on deleting copy programs, refer to “To delete a copy program” on page 4-13.

- 4 Use the keyboard that appears in the touch panel to type in the name of the copy program.

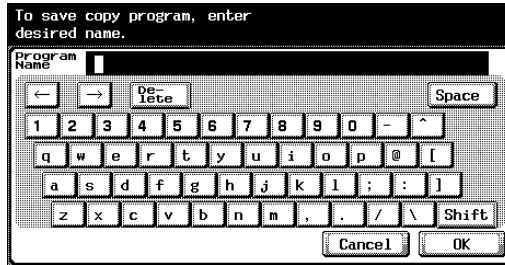

- A name of up to 16 characters can be specified for the registered copy program. (For details, refer to page 13-2.)

- 5 After typing in the name, touch [OK].

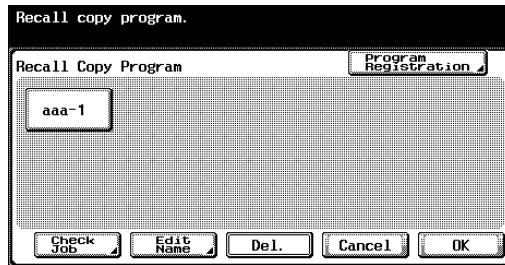

- The copy program can be given the same name as a copy program that has already been registered.

The Recall Copy Program screen appears again. The copy program is registered and a button with the entered copy program name appears.

? Can the copy program name be corrected?

→ To change the entered copy program name, touch the button whose name is to be changed, and then touch [Edit Name]. The Edit Name screen appears. Return to step 4.

? Can the specified settings for a copy program be checked?

→ To check the programmed copy settings, touch the button for the desired copy program, and then touch [Check Job]. For details, refer to “Copying with programmed copy settings (Mode Memory)” on page 4-14.

? How is job deleted?

→ Touch the button for the desired copy program, and then touch [Del.]. In the screen that appears, requesting confirmation to delete the copy program, touch [Yes] to delete the selected copy program.

- 6 Touch [OK] or [Cancel].
- To return to the Basic screen, press the [Mode Memory] key.

**Detail**

Copy programs cannot be changed.

If a copy program is selected where the “Restrict Access to Saved Program Jobs” parameter has been set, [Edit Name] and [Del.] do not appear. For details, refer to “System setting” on page 12-27.

To stop registering the program, press the [Reset] key or the [Mode Memory] key.

No matter which screen is displayed, the registration is cancelled.

Otherwise, continue to touch [Cancel] until the Basic screen is displayed.

To delete a copy program

- 1 In the Recall Copy Program screen, touch the button for the copy program to be deleted.
- 2 Touch [Del.].

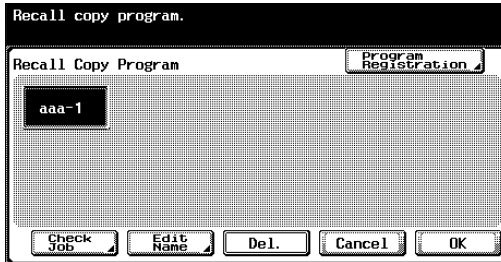

A message appears, requesting confirmation to delete the copy program.

- 3 Touch [Yes].



The Recall Copy Program screen appears again. The copy settings registered in the copy program are erased.

4.5 Copying with programmed copy settings (Mode Memory)

To recall a stored job

Programmed copy settings can be recalled to be used again for copying.

- 1 Position the document to be copied. (For details, refer to page 3-7.)
- 2 Press the [Mode Memory] key.

The Recall Copy Program screen appears.

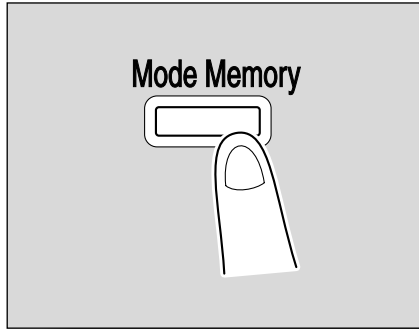

- 3 Touch the button for the copy program registered with the desired copy settings.

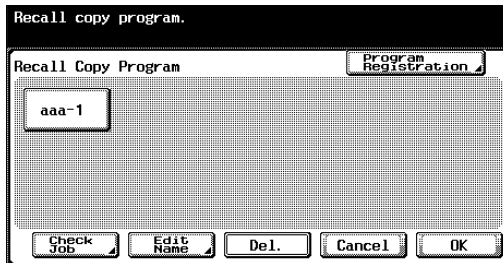

- If the copy settings in the selected copy program are not to be checked, skip to step 8.

- 4 Touch [Check Job].

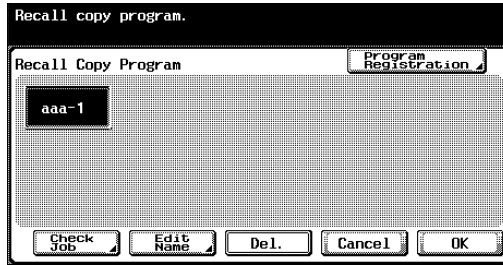

The Mode Check screens for the copy job appear. The buttons for functions where the setting has been changed from the default appear selected.

- 5 Check the copy settings registered with the selected copy program.
- 6 Touch [Job End].

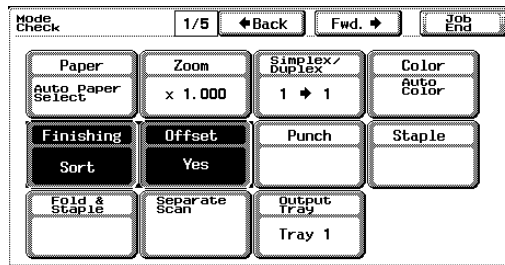

The Recall Copy Program screen appears again.

- ? Can different settings be displayed?
 → To display the previous screen, touch [←Back]. To display the next screen, touch [Fwd.→].

- 7 Again touch the button for the program with the desired copy settings.
- If [OK] is touched with no copy program selected, the Basic screen appears again without a copy program recalled.
- 8 Touch [OK].

The programmed copy settings are recalled and the Basic screen appears again.

- 9 Press the [Start] key.
Copying begins with the recalled copy settings.

**Note**

To stop recalling the copy program, press the [Reset] key or the [Mode Memory] key, or touch [Cancel].

The copy settings cannot be changed from the Mode Check screens.

4.6 Displaying function descriptions (Help)

Descriptions of the various functions and details of operations can be viewed.

There are two methods for displaying the Help screens.

- Main Help Menu screen (from the Basic screen)
- Setting Help screens (from screens other than the Basic screen)

Overview of Help Screens

The Help feature provides of the following menus.

Main Help Menu screen (1st level)

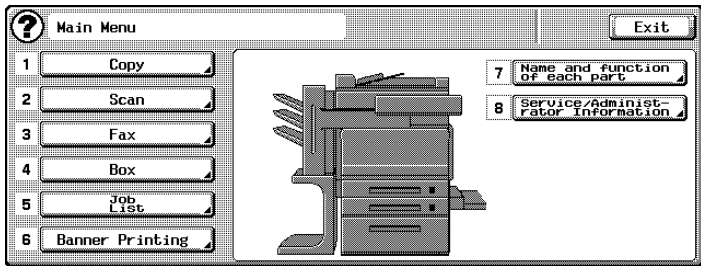

Item	Description
[Copy], [Scan], [Fax], [Box], [Job List], [Banner Printing]	Displays the Help menu for the corresponding mode
[Name and function of each part]	Displays the Help menu for the name and function of each part Use to check the description of the main unit and its options.
[Service/Administrator Information]	Displays the name, extension number and e-mail address of the administrator



Detail

Items in the Main Help Menu and the Help Menu screens can be selected by touching the button or by pressing the key in the keypad for the number of the desired item.

To display the next screen higher in the menu structure, touch [⏪].

Touch [Exit] to quit the Help mode and return to the screen that was displayed before the [Help] key was pressed.

Help Menu screen (2nd level) (Example: [Copy])

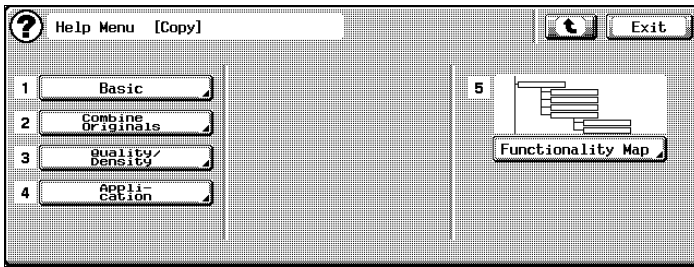

Item	Description
[Basic], [Combine Originals], [Quality/Density], [Application]	Displays the first Help screen for each description
[Functionality Map]	Displays the Function Map screen, which contains a chart of the available functions and settings

**Detail**

The items displayed in the Help menu for the name and function of each part differ depending on the options that are installed.

Help screens (3rd level) (Example: [Copy], then [Basic])

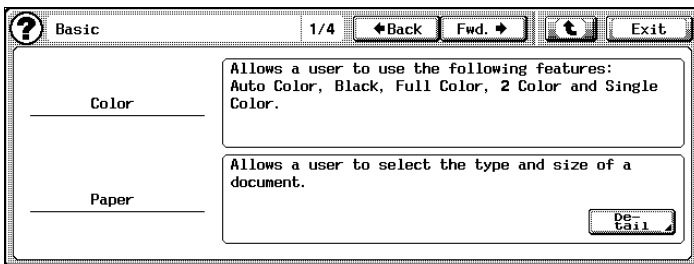



Detail

The numbers to the right of the screen title ("1/4" in the previous screen) indicate the number of the currently displayed screen/total number of Help screens for the displayed item.

To display the previous screen, touch [←Back]. To display the next screen, touch [Fwd.→].

To view detailed descriptions (in the 4th level of the Help screens), touch [Detail], if it appears in the screen.

Function maps (Example: [Copy])

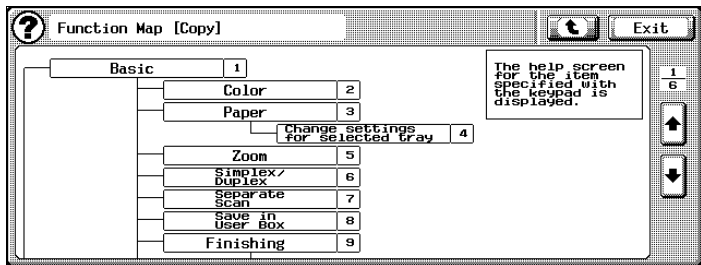

A chart of the available functions and settings are displayed in the function maps. Select an item from the chart for the Help screen that you wish to view.



Detail

There are six Function Map screens for Copy mode. The top number indicates the number of the six screens that is currently displayed.

To display the previous screen, touch [↶]. To display the next screen, touch [↷].

Press the key in the keypad for the number of the desired item in the Function Map screen.

To return to the Help Menu screen, touch [⏪] in the Help screen displayed by selecting an item in a Function Map screen.

To display the Main Help Menu screen

When a Help screen can be displayed,  appears in the upper-left corner of the screen.

- ✓ The Help screens cannot be displayed when the following operations are being performed.
While scanning, while printing, while printing a proof copy, during Enlarge Display mode, during Accessibility mode
- ✓ While the Help screens are displayed, the following keys are not available.
[Start], [Stop], [C] (clear), [Interrupt], [Proof Copy], [Access], [Mode Memory], [Enlarge Display], [Mode Check]

- 1 With the Basic screen displayed, press the [Help] key.
The Main Help Menu screen appears.



- 2 Touch [Copy] or press the [1] key in the keypad.

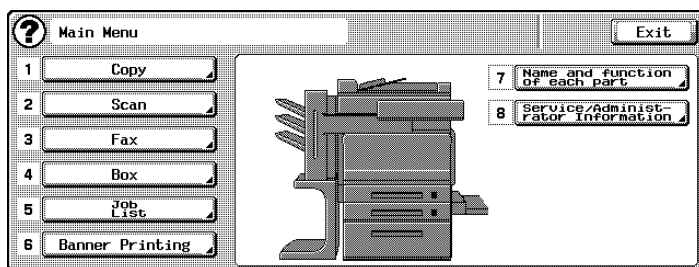

The Help Menu [Copy] screen appears.

- ? Is there more information about the buttons of the Help screens?
- Refer to “Overview of Help Screens” on page 4-17.

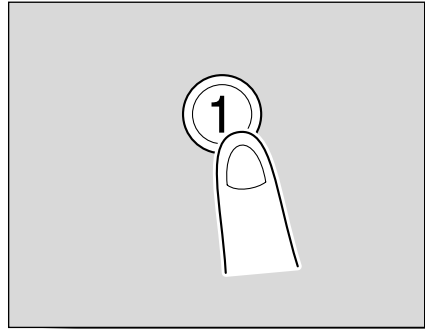

- 3 Touch the button for the desired information or press the key in the keypad for the number to the left of the desired information to display the corresponding Help screen.

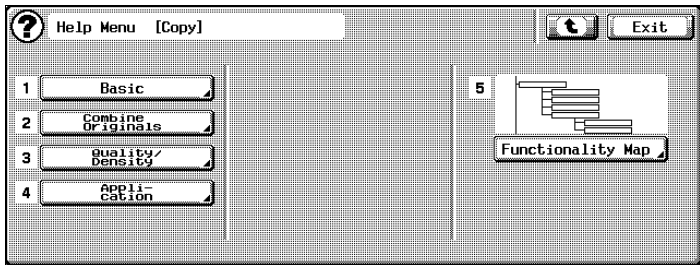

- 4 After checking the Help information, touch [Exit] or press the [Help] key. The Basic screen appears again.

To display the Help screen while specifying a setting

Help can be displayed for the copy settings that are being specified.

- 1 Display the setting screen for the desired copy setting, and then press the [Help] key.

A Help screen containing details of the functions and operations.

? Why is there no Help information for some functions in the Help Menu screen?

→ Depending on the displayed screen, there may be no Help information for some functions.

? Is there more information about the buttons of the Help screens?

→ Refer to “Overview of Help Screens” on page 4-17.

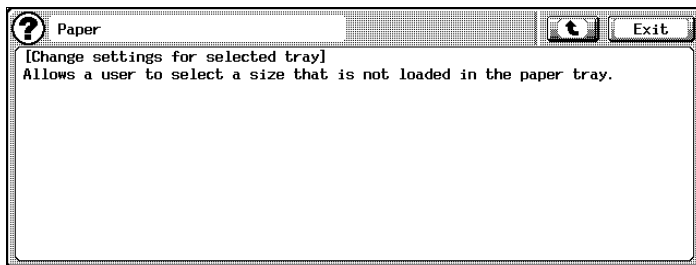

- 2 After checking the Help information, touch [Exit] or press the [Help] key.
 - To display the next screen higher in the menu structure than the displayed Help Menu screen, touch [].

The screen that was displayed before the [Help] key was pressed appears again.

4.7 Specifying control panel settings (Accessibility mode)

This section contains details on the procedures for specifying control panel settings and adjusting the touch panel.

Displaying the Accessibility Setting Screen

- Press the [Accessibility] key.
The Accessibility Setting screen appears.

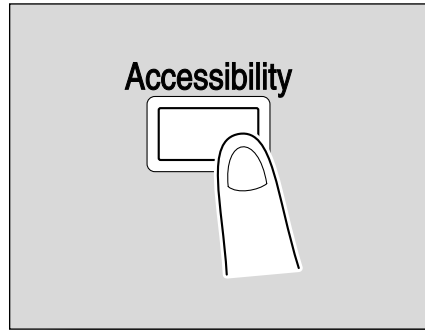

To set the “Key Repeat Start/Interval Time” function

The length of time until the value begins to change after a touch panel button is held down and the length of time for the value to change to the next number can be specified. The factory default setting for “Time To Start” is 0.8 second and the factory default setting for “Interval” is 0.3 second.

- ✓ The settings specified for the “Key Repeat Start/Interval Time” function are only applied in the Enlarge Display mode.

- 1 Display the Accessibility Setting screen. (To display the screen, refer to page 4-23)
- 2 Touch [Key Repeat Start/Interval Time] or press the [1] key in the keypad.

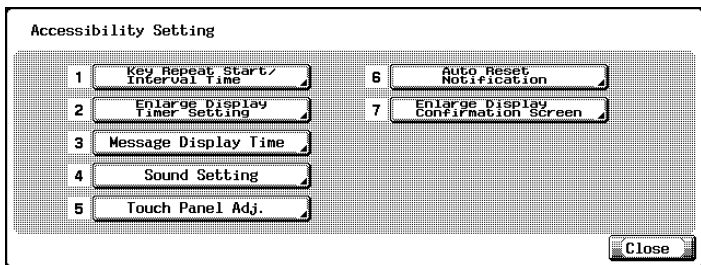

The Key Repeat Start/Interval Time screen appears.

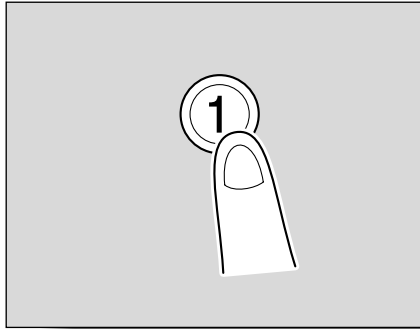

- 3 Touch [+] and [-] to specify the starting time and the interval for the key repeat feature.

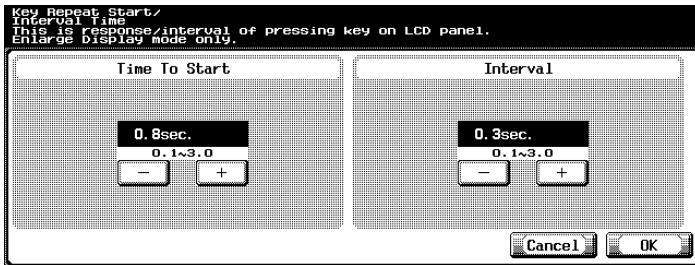

- Both settings can be set between 0.1 and 3.0 seconds in 0.1-second intervals.
- To cancel changes to the settings, touch [Cancel].

- 4 Touch [OK].
The Accessibility Setting screen appears again.
- 5 Touch [Close] or press the [Accessibility] key.
The Basic screen appears again.



Note

The Enlarge Display mode is compatible with basic copy, scanning and fax functions. The function and setting names and the illustrations are displayed at a larger size so that they can be seen more easily. For details on the Enlarge Display mode, refer to the Enlarge Display Operations of the User's Guide.

**Detail**

To return to the Basic screen from the Accessibility Setting screen, press the [Accessibility] key or the [Reset] key.

To set the “Enlarge Display Timer Setting” function

When the automatic panel reset operation is performed, a message requesting confirmation to cancel Enlarge Display mode can be displayed.

In addition, it is possible to specify the length of time that the message requesting confirmation to cancel Enlarge Display mode is displayed.

The factory default setting is “OFF”.

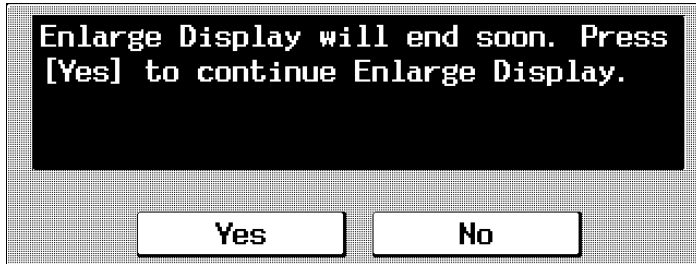

- 1 Display the Accessibility Setting screen. (To display the screen, refer to page 4-23)
- 2 Touch [Enlarge Display Timer Setting] or press the [2] key in the keypad.

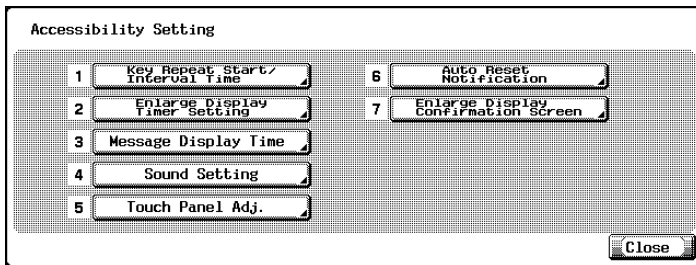

The Enlarge Display Timer Setting screen appears.

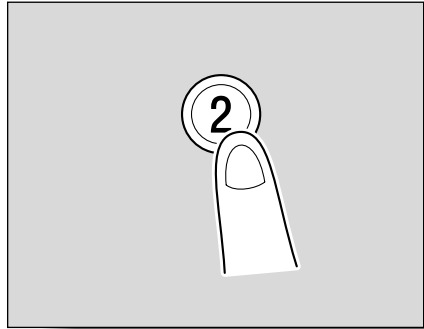

3 Select the desired setting.

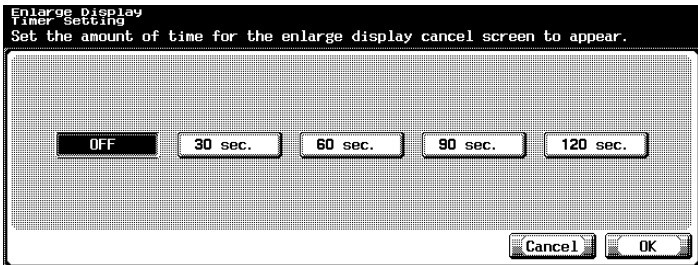

- To not display the message requesting confirmation to cancel Enlarge Display mode, touch [OFF].
- To display the message requesting confirmation to cancel Enlarge Display mode, touch the button ([30 sec.], [60 sec.], [90 sec.] or [120 sec.]) for the length of time that the message is to be displayed.
- To cancel changes to the settings, touch [Cancel].

4 Touch [OK].

The Accessibility Setting screen appears again.

5 Touch [Close] or press the [Accessibility] key.

The Basic screen appears again.



Note

The Enlarge Display mode is compatible with basic copy, scanning and fax functions. The function and setting names and the illustrations are displayed at a larger size so that they can be seen more easily. For details on the Enlarge Display mode, refer to the Enlarge Display Operations of the User's Guide.

To set the “Message Display Time” function

It is possible to specify the length of time for displaying warning messages, which appear, for example, when an incorrect operation is performed.

The factory default setting is “3 sec.”.

- 1 Display the Accessibility Setting screen. (To display the screen, refer to page 4-23)
- 2 Touch [Message Display Time] or press the [3] key in the keypad.

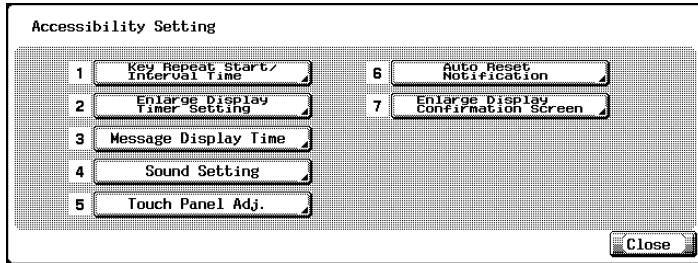

The Message Display Time screen appears.

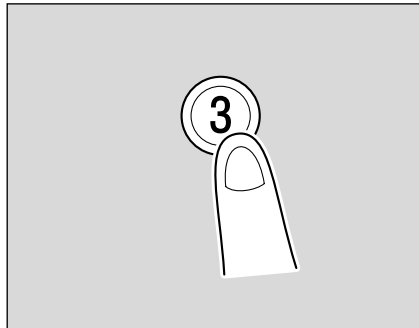

- 3 Select setting for the desired amount of time that messages are displayed.

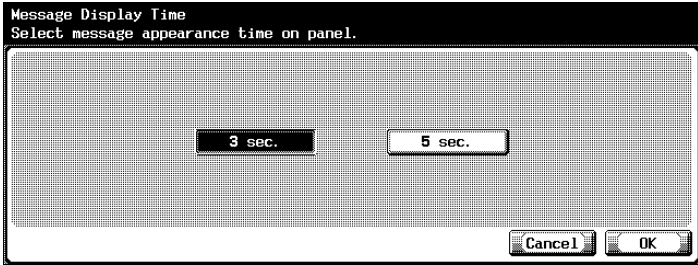

- Select whether messages are displayed for 3 seconds or for 5 seconds.
 - To cancel changes to the settings, touch [Cancel].
- 4 Touch [OK].
The Accessibility Setting screen appears again.
 - 5 Touch [Close] or press the [Accessibility] key.
The Basic screen appears again.

To set the “Sound Setting” function

Specify the sound that is produced when a key is pressed.

In addition, you can set whether or not a sound is produced when a control panel key is pressed or a touch panel button is touched.

The factory default setting for “Accept Sound Setting” is “ON”.

- 1 Display the Accessibility Setting screen. (To display the screen, refer to page 4-23)
- 2 Touch [Sound Setting] or press the [4] key in the keypad.

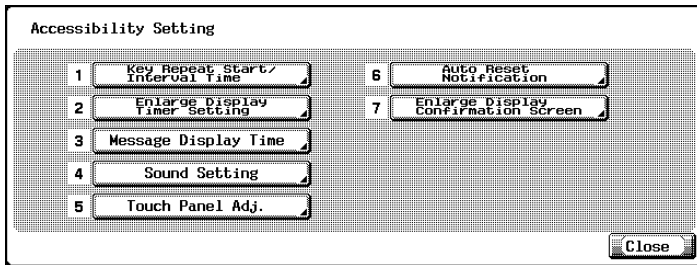

The Sound Setting screen appears.

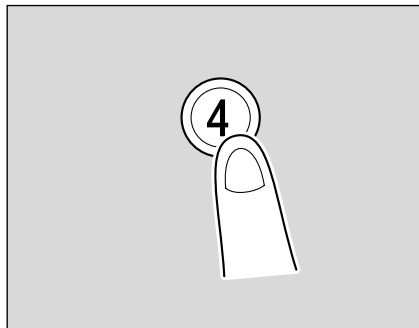

- 3 Touch [Key Accept Sound/Key Refuse Sound] or press the [1] key in the keypad.

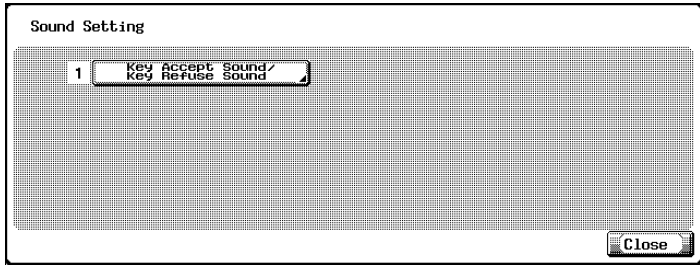

The Key Accept Sound/Key Refuse Sound screen appears.

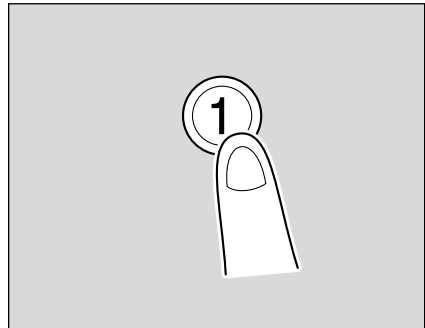

- 4 Specify the setting for “Accept Sound Setting”.
 - To produce a sound, touch [ON]. To not produce a sound, touch [OFF].

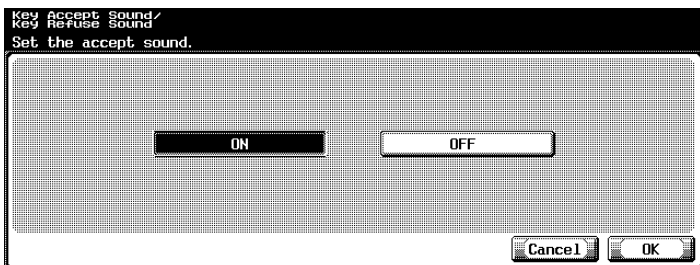

- To cancel changes to the settings, touch [Cancel].

- 5 Touch [OK].
The Sound Setting screen appears again.

- 6 Touch [Close].
The Accessibility Setting screen appears again.
- 7 Touch [Close] or press the [Accessibility] key.
The Basic screen appears again.

To set the “Touch Panel Adj.” function

If the touch panel buttons do not respond correctly, the position of buttons in the touch panel may not be correctly aligned with the position of the actual touch sensor and may need to be adjusted.

- 1 Display the Accessibility Setting screen. (To display the screen, refer to page 4-23)
- 2 Touch [Touch Panel Adj.] or press the [5] key in the keypad.

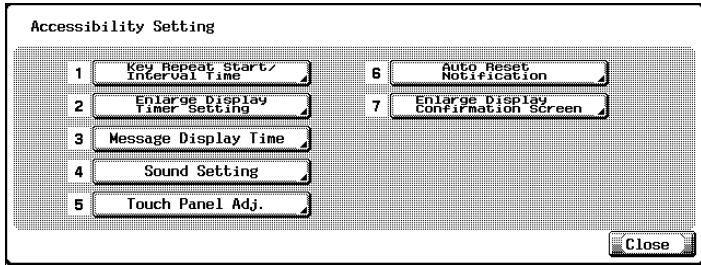



The Touch Panel Adjustment screen appears.

? Why does the machine not respond when [Touch Panel Adj.] is touched?

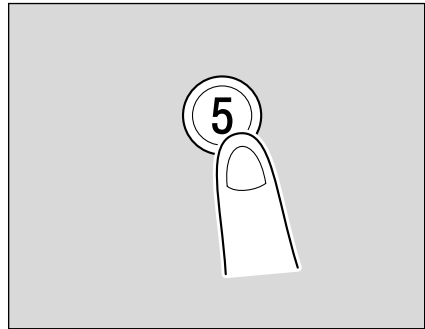

The touch sensors are not aligned on the touch panel.

→ Press the [5] key in the keypad.

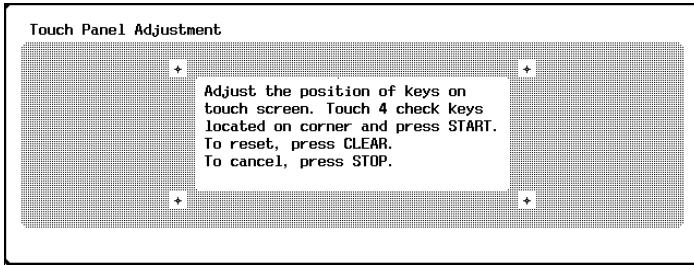

- 3 Touch the four check points (), making sure that a sound is produced with each.



- The check points () can be touched in any order.
- To reset the adjustment, press the [C] (clear) key, and then touch the four check points ().

If the check points have been touched correctly, the indicator on the [Start] key lights up in green.

- 4 Press the [Start] key.

The touch panel is adjusted, and the Accessibility Setting screen appears again.

- 5 Touch [Close] or press the [Accessibility] key.

The Basic screen appears again.



Note

If the touch panel cannot be adjusted, contact the technical representative.



Detail

To cancel the touch panel adjustment, press the [Stop] key or the [Reset] key.

To set the “Auto Reset Notification” function

When the automatic panel reset operation is performed, a message can be displayed, requesting confirmation to reset the settings in Enlarge Display mode.

In addition, it is possible to specify when the message is displayed, requesting confirmation to reset the settings in Enlarge Display mode.

The factory default setting is “OFF”.

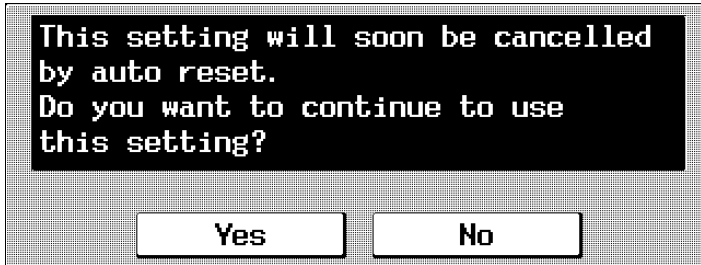

- 1 Display the Accessibility Setting screen. (To display the screen, refer to page 4-23)
- 2 Touch [Auto Reset Notification] or press the [6] key in the keypad.

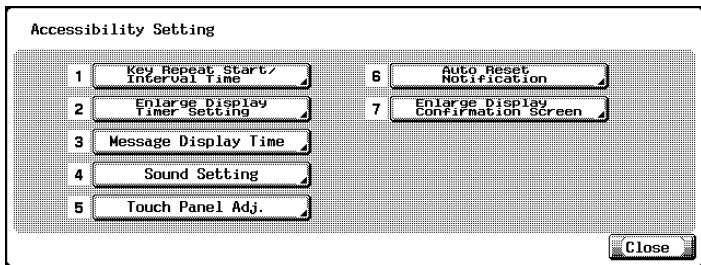

The Auto Reset Notification screen appears.

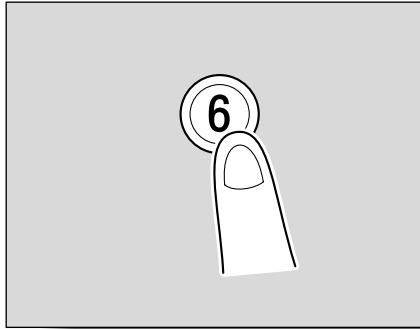

- 3 Touch the button for the desired display time.

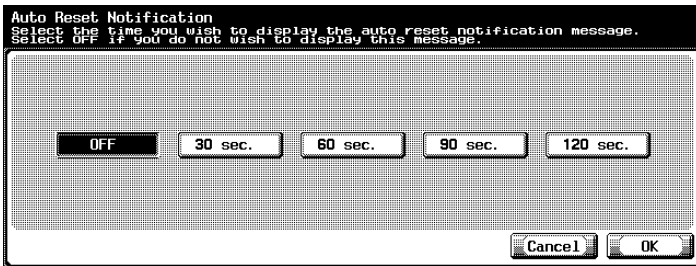

- To not display the message requesting confirmation to reset the settings in Enlarge Display mode, touch [OFF].
- To display the message requesting confirmation to reset the settings in Enlarge Display mode, touch the button ([30 sec.], [60 sec.], [90 sec.] or [120 sec.]) for the length of time that the message is to be displayed.
- To cancel changes to the settings, touch [Cancel].

- 4 Touch [OK].
The Accessibility Setting screen appears again.

- 5 Touch [Close], or press the [Accessibility] key.
The Basic screen appears again.

**Note**

The Enlarge Display mode is compatible with basic copy, scanning and fax functions. With the Enlarge Display mode, text and illustrations are displayed at a larger size so that they can be seen more easily. For details on the Enlarge Display mode, refer to the User's Guide [Enlarge Display Operations].

If the time setting is the same for the automatic panel reset operation and the automatic system reset operation, the display of the message requesting confirmation to cancel Enlarge Display mode is given priority and the message requesting confirmation to reset the settings in Enlarge Display mode is not displayed.

To set the “Enlarge Display Confirmation Screen” function

When the [Enlarge Display] key is pressed to change the display of the screen, a message can be displayed, requesting confirmation to reset the settings to their defaults.

The factory default setting is “No”.

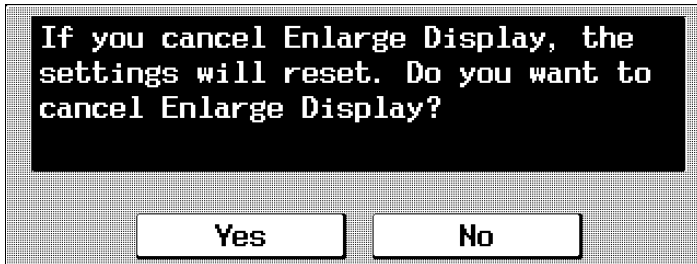

- 1 Display the Accessibility Setting screen. (To display the screen, refer to page 4-23)
- 2 Touch [Enlarge Display Confirmation Screen] or press the [7] key in the keypad.

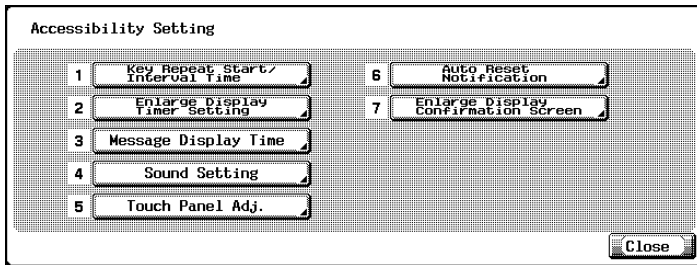

The Enlarge Display Confirmation Screen appears.

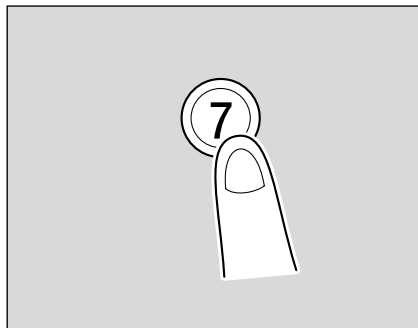

- 3 Select whether or not the message is displayed.

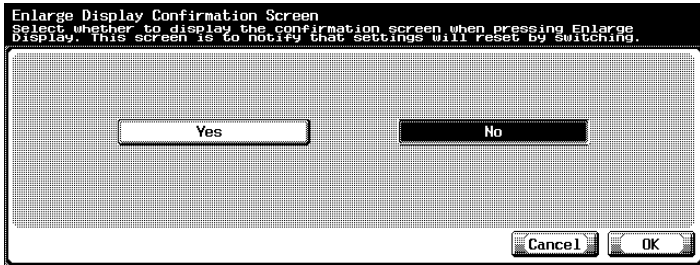

- To cancel changes to the settings, touch [Cancel].

- 4 Touch [OK].
The Accessibility Setting screen appears again.
- 5 Touch [Close], or press the [Accessibility] key.
The Basic screen appears again.

**Note**

The Enlarge Display mode is compatible with basic copy, scanning and fax functions. With the Enlarge Display mode, text and illustrations are displayed at a larger size so that they can be seen more easily. For details on the Enlarge Display mode, refer to the User's Guide [Enlarge Display Operations].

If [No] is touched in the message requesting confirmation to enter Enlarge Display mode, the screens are not changed.



Troubleshooting

5 Troubleshooting

5.1 When the message “malfunction detected.” appears (call technical representative)

If a malfunction that cannot be corrected by the user occurred, the message “Malfunction detected. Please call your Technical Representative.” appears. (call technical representative screen)

The phone number and fax number for the usual technical representative appears in the center of the call technical representative screen.

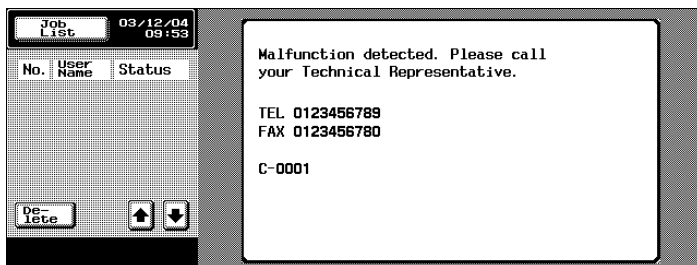

Display in Enlarge Display mode

If a malfunction occurs, the screen shown below appears.



Touch  to display the message shown in the following illustration.

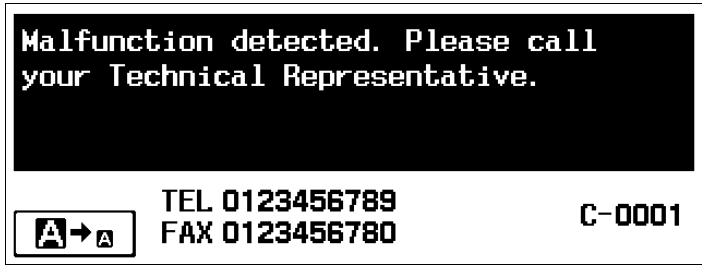

To call the technical representative

- 1 Write down the malfunction code (for example, C-0001) in the call technical representative screen.
- 2 Press the [Power] (auxiliary power) button to turn off the control panel.

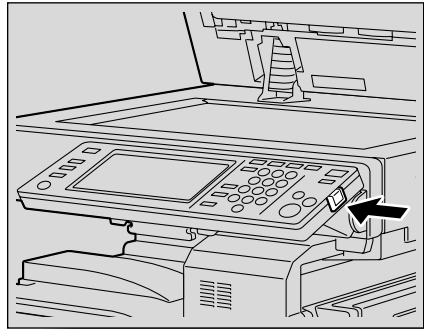

- 3 Use the main power switch to turn off the machine.

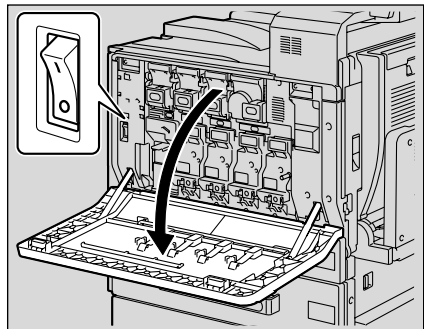

- 4 Unplug the machine.
- 5 Contact the technical representative, and inform them of the malfunction code.

**Reminder**

Since the machine may be damaged, contact the technical representative according to the procedure described above as soon as the call technical representative screen appears.

5.2 When the message “Misfeed detected.” appears

If a misfeed occurs during copying or printing, the message “Misfeed detected.” appears and the location of the misfeed is indicated in the screen. (misfeed screen)

At this time, copying and printing cannot continue until the misfeed is adequately cleared.

Location of Paper misfeed

A flashing “○” indicates the location of the paper misfeed. In addition, a lit “○” indicates areas where paper may have been misfed and that should be checked.

Example: Screen when a paper misfeed occurs in a paper tray

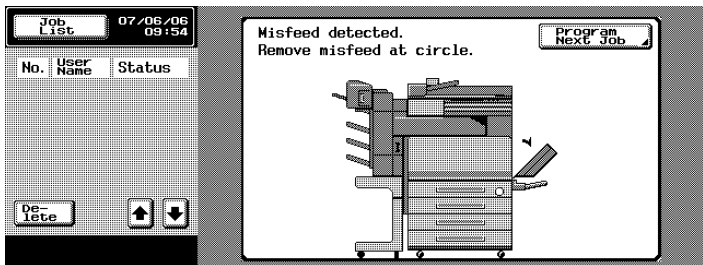

Note

The procedure for clearing a misfed paper differs depending on where the misfeed occurs. Determine the misfeed location by looking at the illustration displayed with the error message, and then clear the misfeed according to the appropriate procedure.

Display in Enlarge Display mode

If a paper misfeed occurs, the screen shown below appears.

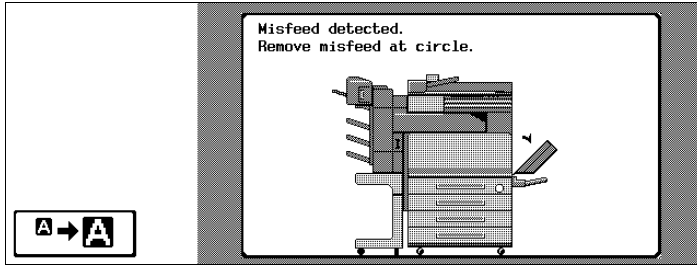

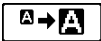
Touch  to display the message shown in the following illustration.

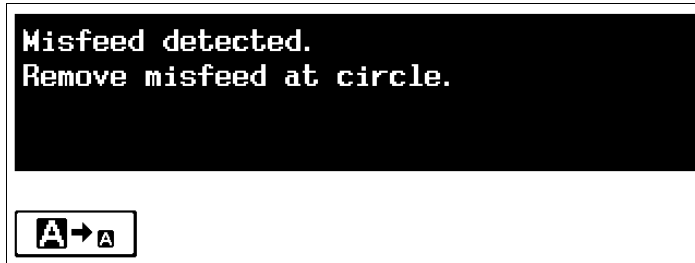

Paper misfeed indications

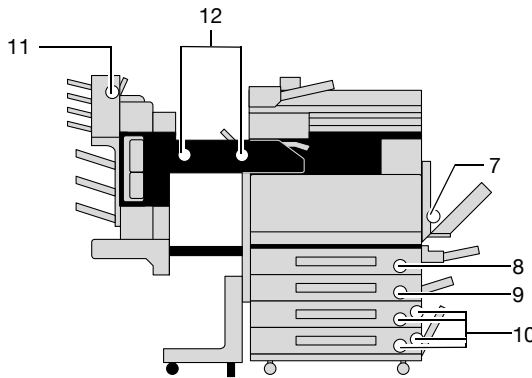
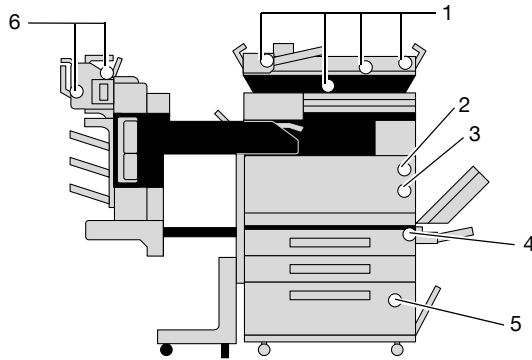

No.	Description
1	A paper misfeed in the ADF (p. 5-28)
2	A paper misfeed in the fusing unit (p. 5-19)
3	A paper misfeed in the main unit (p. 5-16)
4	A paper misfeed in the bypass tray (p. 5-9)
5	A paper misfeed in the LCT (p. 5-14)
6	A paper misfeed in the saddle stitcher (p. 5-38)
7	A paper misfeed in the automatic duplex unit (p. 5-10)
8	A paper misfeed in the 1st tray (p. 5-11)
9	A paper misfeed in the 2nd tray (p. 5-12)
10	A paper misfeed in the 3rd or 4th tray (p. 5-13)
11	A paper misfeed in the mailbin (p. 5-36)
12	A paper misfeed in finisher FS-514 (p. 5-32)

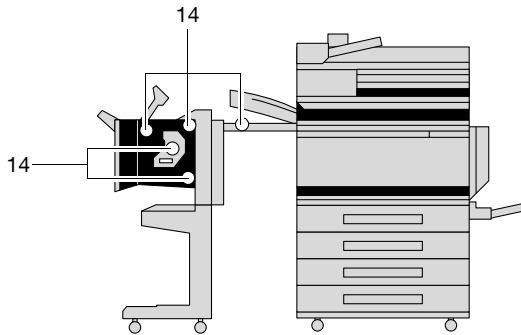
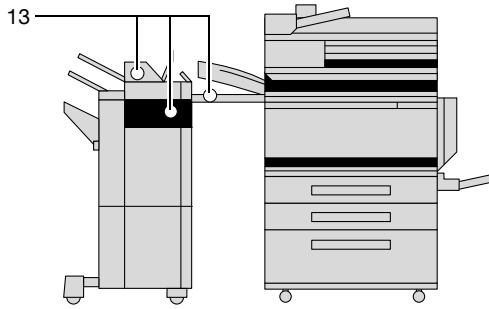

No.	Description
13	A paper misfeed in finisher FS-501/job separator JS-601 (p. 5-40)
14	A paper misfeed in finisher FS-603 (p. 5-45)

To clear a paper misfeed in the bypass tray

- 1 Remove all paper from the bypass tray.

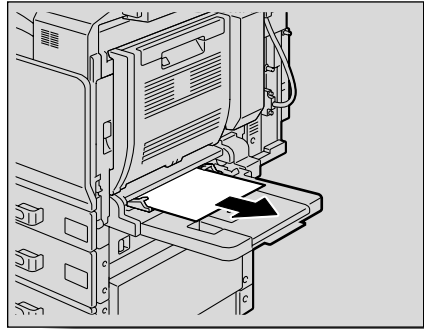

- 2 If the misfed paper cannot be removed, open the upper right-side door, and then carefully pull out any misfed paper.

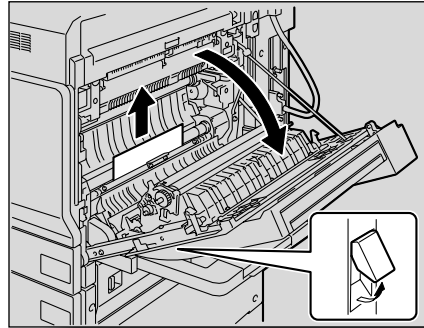

- 3 Close the upper right-side door.



Detail

For details on the positions of paper misfeeds, refer to "Paper misfeed indications" on page 5-7.

To clear a paper misfeed in the automatic duplex unit

- 1 Open the automatic duplex unit door.

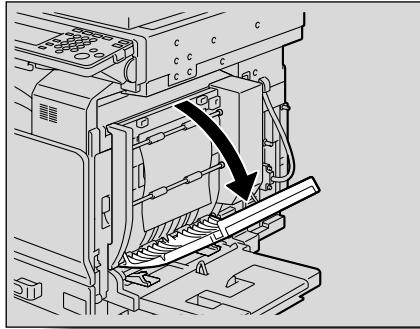

- 2 Carefully pull out any misfed paper.

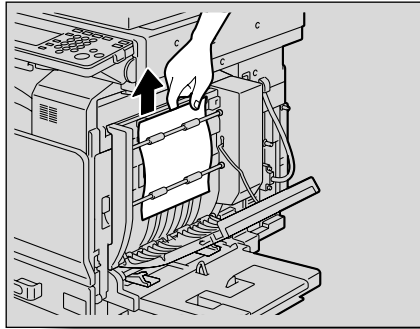

- 3 Close the automatic duplex unit door.



Detail

For details on the positions of paper misfeeds, refer to “Paper misfeed indications” on page 5-7.

To clear a paper misfeed in the 1st tray

- 1 Pull up the upper right-side door release lever, and then open the upper right-side door.

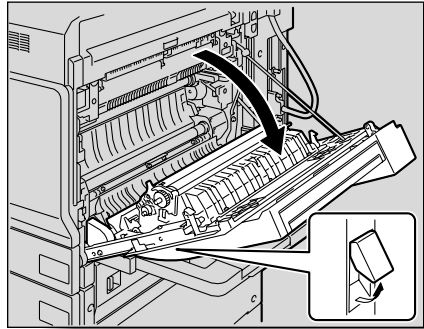

- 2 Carefully pull out any misfed paper.

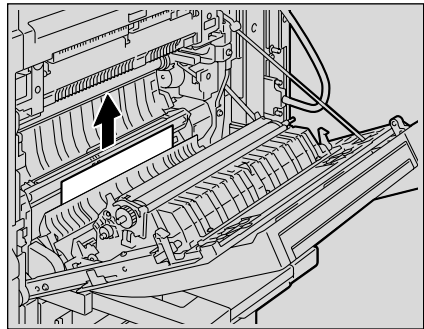

- 3 Close the upper right-side door.
- 4 Pull out the 1st tray, and then remove any misfed paper.
- 5 Close the 1st tray.



Reminder

Be careful not to touch the surface of the paper take-up roller with your hands.



Detail

For details on the positions of paper misfeeds, refer to "Paper misfeed indications" on page 5-7.

To clear a paper misfeed in the 2nd tray

- 1 Pull up the center right-side door release lever, and then open the center right-side door.

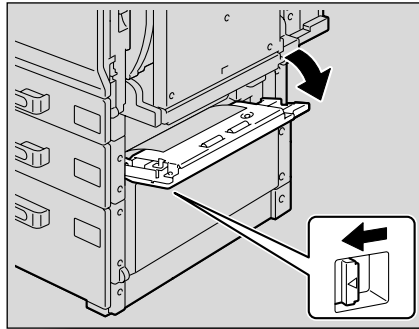

- 2 Carefully pull out any misfed paper.

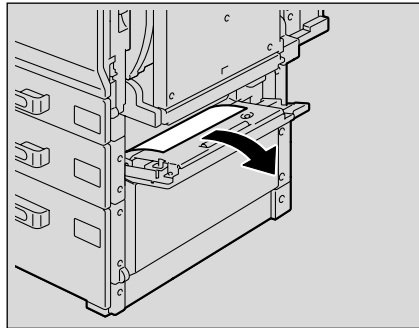

- 3 Close the center right-side door.
- 4 Pull out the 2nd tray, and then remove any misfed paper.
- 5 Close the 2nd tray.

**Reminder**

Be careful not to touch the film with your hands.

To clear a paper misfeed in a paper tray (3rd or 4th tray)

- 1 Pull up the lower right-side door release lever, and then open the lower right-side door.

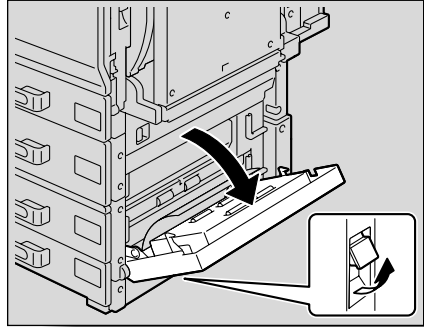

- 2 Carefully pull out any misfed paper.

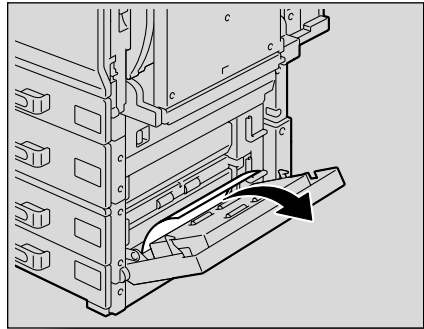

- 3 Close the lower right-side door.
- 4 Pull out the paper tray, and then remove any misfed paper.
- 5 Close the paper tray.



Reminder

Be careful not to touch the film.



Detail

For details on the positions of paper misfeeds, refer to “Paper misfeed indications” on page 5-7.

To clear a paper misfeed in the LCT

- 1 Pull up the lower right-side door release lever, and then open the lower right-side door.

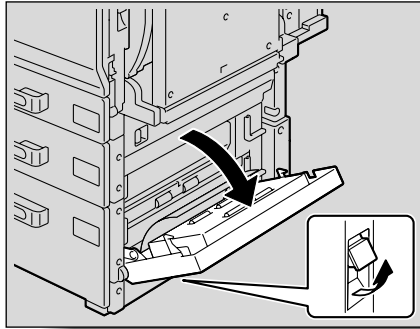

- 2 Carefully pull out any misfed paper.

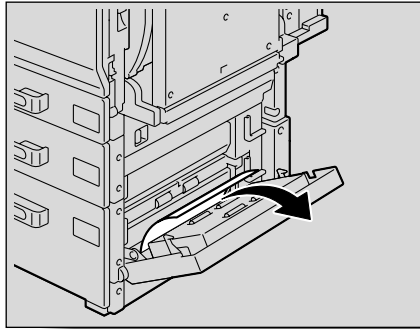

- 3 Close the lower right-side door.
- 4 Press the tray release button, pull out the LCT, and then remove any misfed paper.
- 5 Close the LCT.



...

Reminder

Be careful not to touch the film.

**Detail**

For details on the positions of paper misfeeds, refer to "Paper misfeed indications" on page 5-7.

To clear a paper misfeed in the right-side door

- 1 Pull out the paper tray being used, and then remove any paper remaining in the tray.

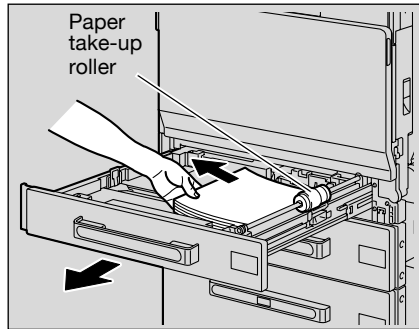

- 2 Load the paper into the paper tray again, and then close the tray.
- 3 Pull up the upper right-side door release lever, and then open the upper right-side door.

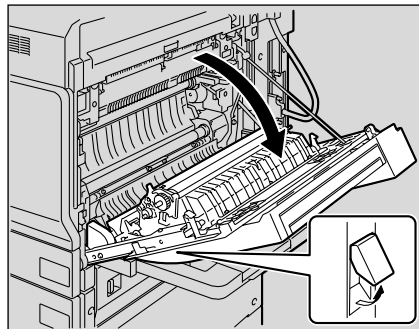

- 4 Open inside cover M1.

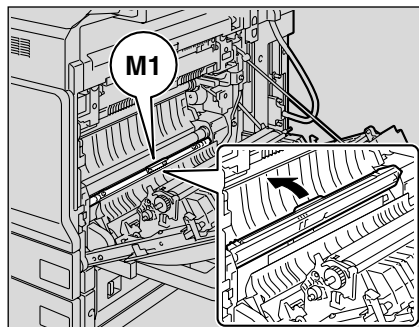

- 5 Pull out any paper caught in the timing roller section.

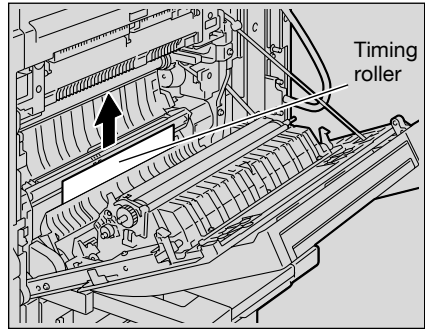

⚠ CAUTION

The area around the fusing unit is extremely hot.



→Touching anything other than the indicated levers and dials may result in burns. If you get burnt, immediately cool the skin under cold water, and then seek professional medical attention.

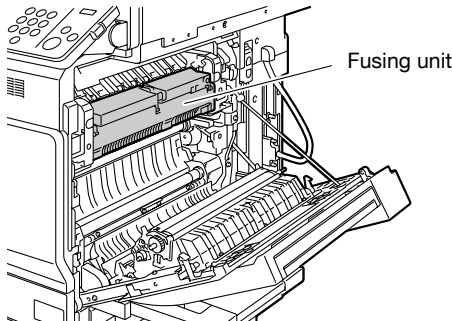

**Reminder**

If the paper is misfed as described below, contact your technical representative.

The paper is wrapped around the timing roller.

The paper is folded or shredded by the timing roller.

Be careful not to touch the surface of the paper take-up roller (in the 1st tray) or the film (in the 2nd, 3rd and 4th trays and in the LCT) with your hands.

Decreased copy quality may result if the surface of the image transfer belt or the image transfer roller is touched. Be careful not to touch the surface of the image transfer belt or the image transfer roller.

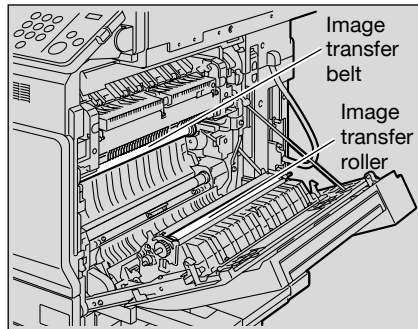
**Detail**

For details on the positions of paper misfeeds, refer to "Paper misfeed indications" on page 5-7.

To clear a paper misfeed in the fusing unit

- 1 Pull up the upper right-side door release lever, and then open the upper right-side door.

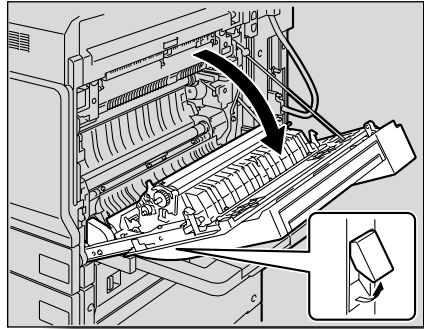

- 2 Push up the fusing unit cover, and then pull out any misfed paper.

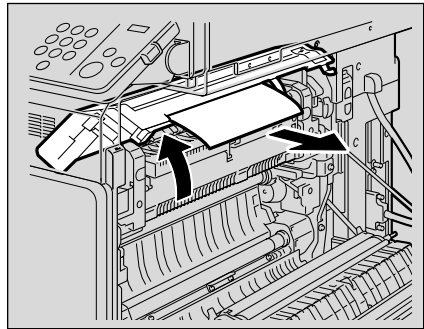

- 3 Push up the M2 release levers. Since the M2 release levers may be difficult to move, push them up forcefully one at a time.

- Do not manually return the M2 release levers to their original positions. They will return to their original positions when the fusing unit cover is closed.

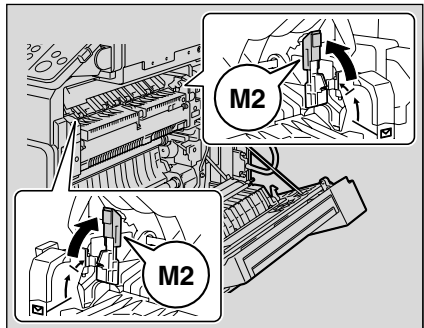

- When returning the M2 release levers to their original positions, do not move them with your hand.

- 4 Pull out any misfed paper.

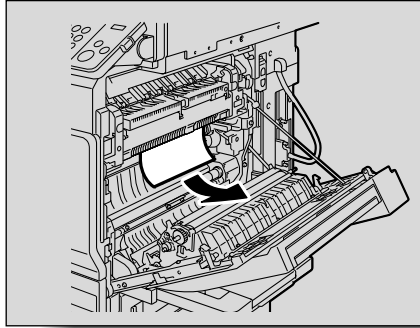

- 5 Pull inside cover M3 toward you to open it, and then pull out any paper caught in the fusing unit.

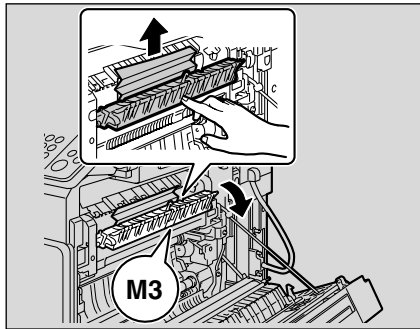

- 6 Close the fusing unit cover.
- When closing the fusing unit cover, also return the M2 release levers to their original positions.

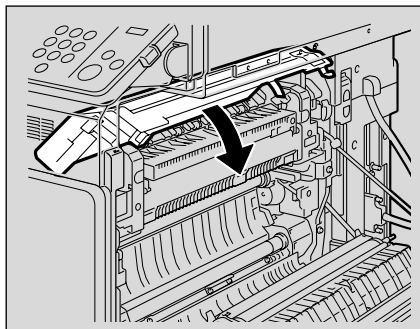

- 7 Close the upper right-side door.

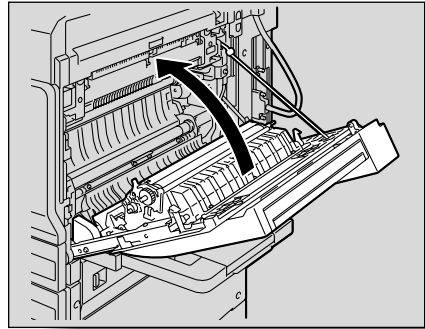

⚠ CAUTION

The area around the fusing unit is extremely hot.



→Touching anything other than the indicated levers and dials may result in burns. If you get burnt, immediately cool the skin under cold water, and then seek professional medical attention.

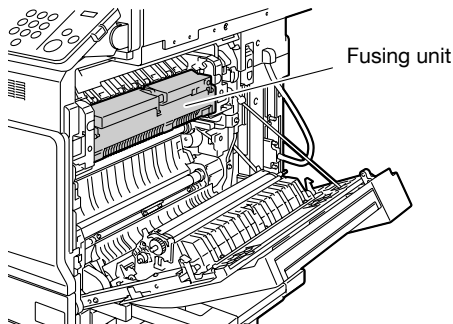

**Reminder**

If the paper is misfed as described below, contact your technical representative.

The paper is wrapped around the roller in the fusing unit.

The paper is folded or shredded by the roller in the fusing unit.

The paper that was removed tore and partly remains in the fusing unit.

Decreased copy quality may result if the surface of the image transfer belt or the image transfer roller is touched. Be careful not to touch the surface of the image transfer belt or the image transfer roller.

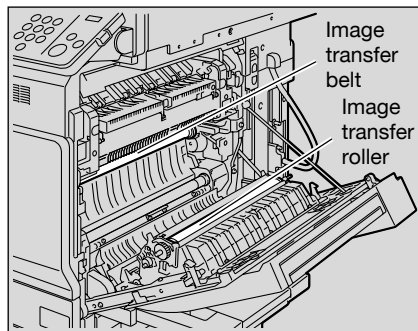
**Detail**

For details on the positions of paper misfeeds, refer to "Paper misfeed indications" on page 5-7.

To clear a banner paper misfeed

- 1 Pull up the upper right-side door release lever, and then open the upper right-side door.

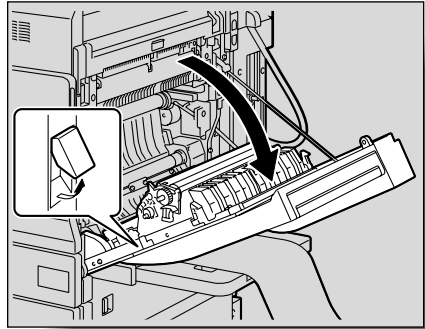

- If the end of the paper cannot be seen or cannot be grabbed, pull out the paper in the direction of the arrow.

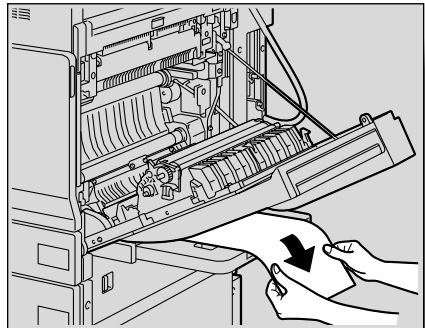

- 2 Open inside cover M1.

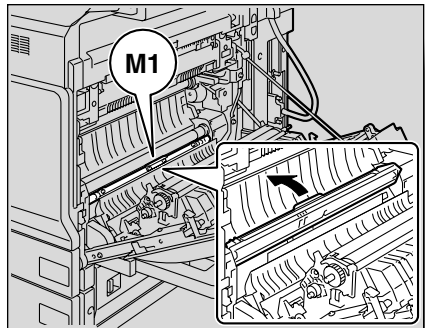

- 3 Pull out any paper caught in the timing roller section.

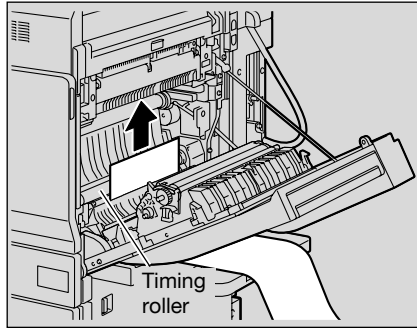

- 4 Push up the M2 release levers. Since the M2 release levers may be difficult to move, push them up forcefully one at a time.

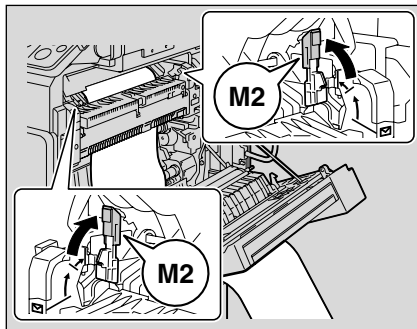

- Do not manually return the M2 release levers to their original positions. They will return to their original positions when the fusing unit cover is closed.
- When returning the M2 release levers to their original positions, do not move them with your hand.

- 5 Push up the fusing unit cover, and then pull out any misfed paper.

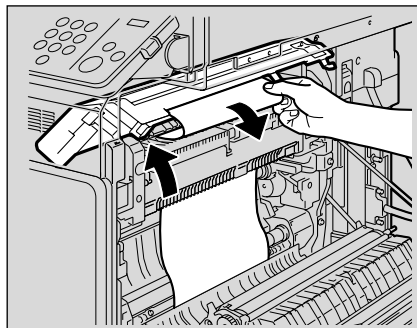

- 6 Pull out any misfed paper.

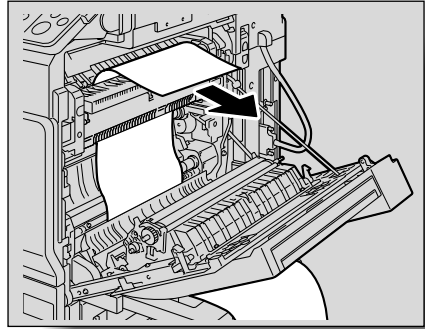

- 7 Pull inside cover M3 toward you to open it, and then pull out any paper caught in the fusing unit.

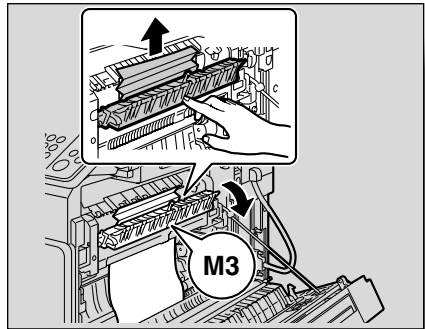

- 8 Close the fusing unit cover.
 - When closing the fusing unit cover, also return the M2 release levers to their original positions.

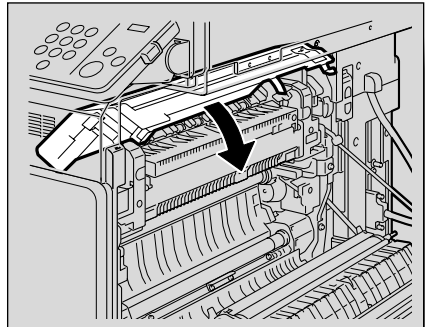

- 9 Close the upper right-side door.

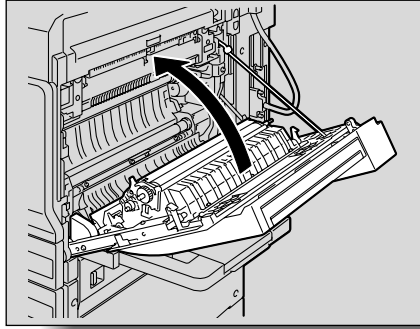

CAUTION

The area around the fusing unit is extremely hot.



→Touching anything other than the indicated levers and dials may result in burns. If you get burnt, immediately cool the skin under cold water, and then seek professional medical attention.

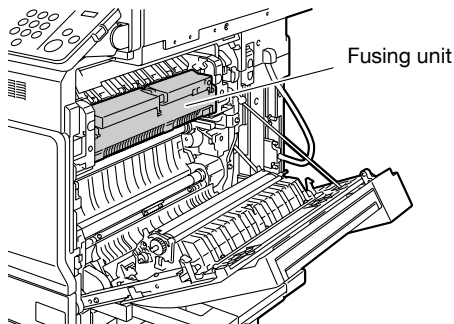



...

Reminder

If the paper is misfed as described below, contact your technical representative.

The paper is wrapped around the roller in the fusing unit.

The paper is folded or shredded by the roller in the fusing unit.

The paper that was removed tore and partly remains in the fusing unit.



...

Reminder

Decreased copy quality may result if the surface of the image transfer belt or the image transfer roller is touched. Be careful not to touch the surface of the image transfer belt or the image transfer roller.

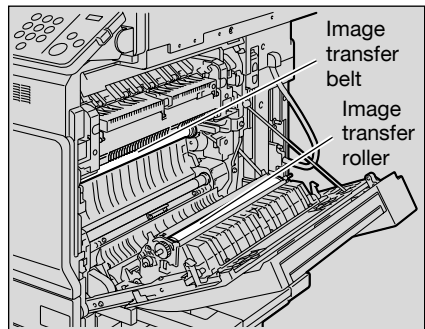

To clear a paper misfeed in the ADF

CAUTION

Precaution when lowering the document exit tray and the document feed tray.

- While lowering the document exit tray and the document feed tray, do not press on the document exit tray support or the document feed tray support, otherwise your hand may be pinched by the trays.

- 1 Open the misfeed-clearing cover on the left side of the ADF, and then carefully pull out any documents from the document feed tray.

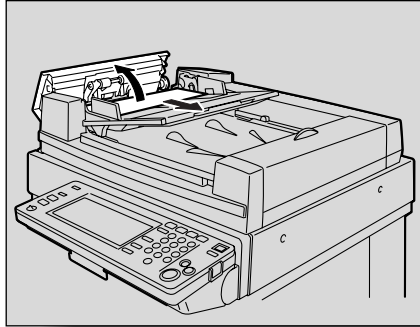

- 2 Open the misfeed-clearing cover on the right side of the ADF. Turn the dial counter-clockwise to feed out any misfed documents, and then carefully pull out the documents.

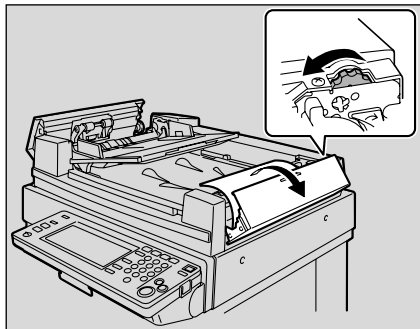

- 3 Push down on the guide. Turn the dial to feed out any misfed documents, and then carefully pull out the documents.

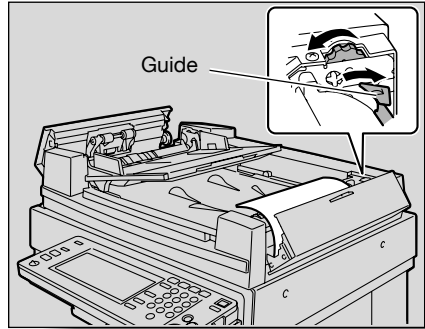

- 4 Carefully open the document exit tray and the document feed tray as far as possible.
 - Make sure that the trays remain open with the document exit tray support and the document feed tray support locked into place.

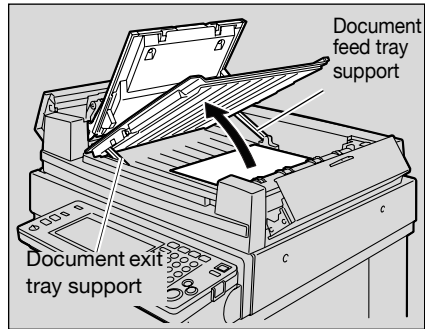

- 5 Turn the dial to feed out any misfed documents, and then carefully pull out the documents.

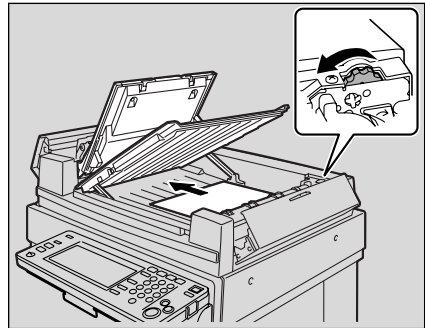

- 6 Lower the document exit tray and the document feed tray.

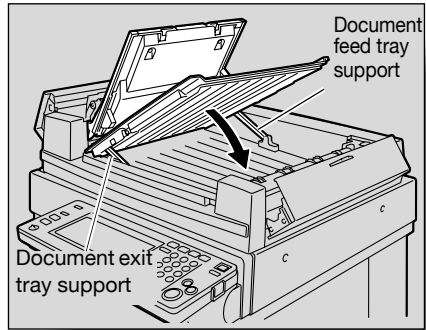

- 7 Open the ADF, and then carefully pull out any misfed documents.

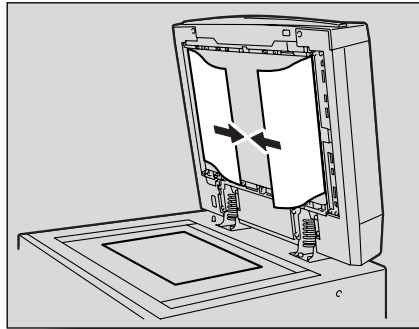

- 8 Remove any documents on the original glass, and then close the ADF.

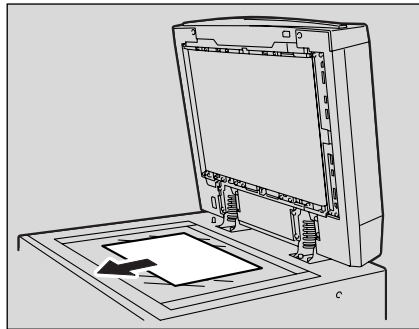

- 9 Close the left-side and right-side misfeed-clearing covers.

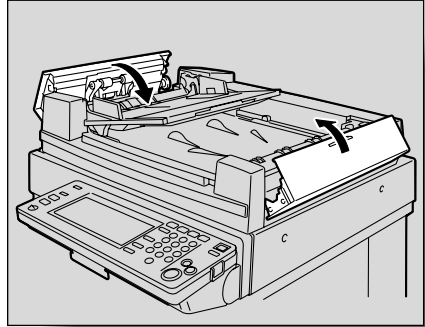

- 10 Reload the documents according to the instructions that appear on the touch panel.

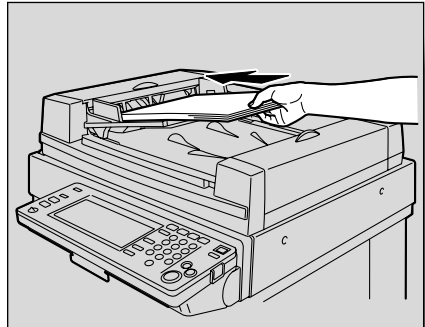

Detail

For details on the positions of paper misfeeds, refer to “Paper misfeed indications” on page 5-7.

To clear a paper misfeed in the finisher FS-514

- 1 Pull the finisher release lever 1 to unlock the finisher.

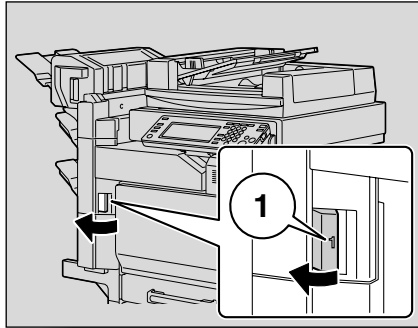

- 2 Grab the finisher at "2", and then slide the finisher away from the main unit.

- To move the finisher away from the main unit, be sure to grab it at "2". Do not grab the mailbins or saddle stitcher to move the finisher, otherwise they may be damaged.

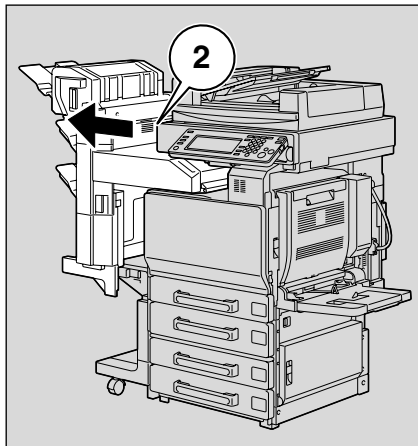

- 3 Open the front door.

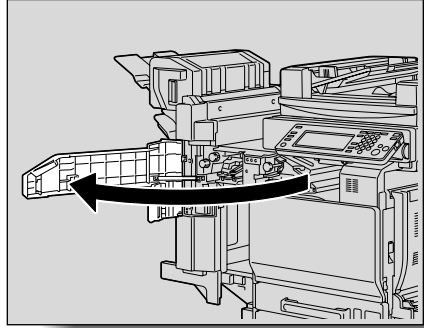

- 4 Raise lever FN1, turn dial FN2, and then pull out any paper.

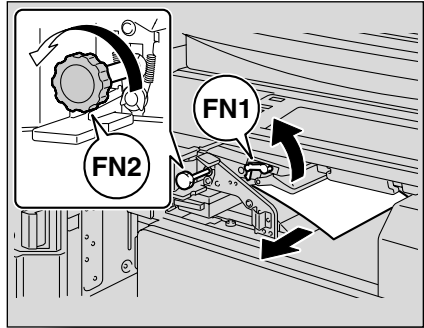

- 5 Lower guide FN3, and then pull out any paper.

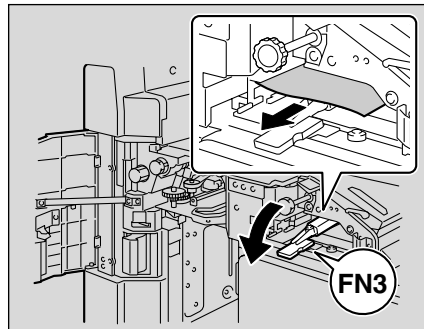

- If the punch kit is installed, pull out the hole-punch waste container FN3.1.

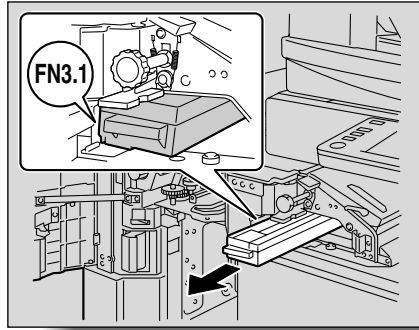

- 6** Return guide FN3 to its original position.
- If the punch kit is installed, insert hole-punch waste container FN3.1 in its original position.

- 7** Turn dial FN4 to feed the paper, open the transport unit cover, and then pull out any paper.

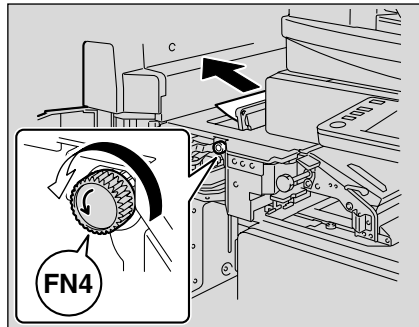

- 8** Turn dial FN5 or dial FN6, and then pull out any paper.

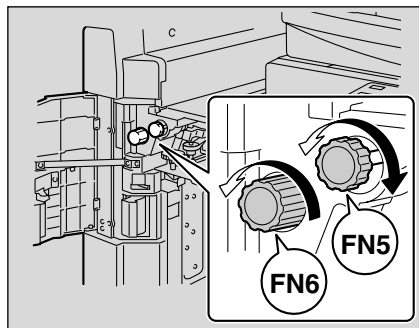

9 Return the finisher to its original position.

- When returning the finisher to its original position, do not grab the handle on the front door, the control panel, the mail-bins, or the saddle stitcher.

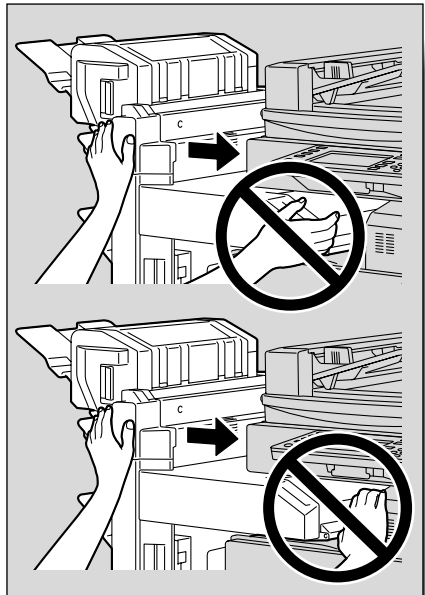
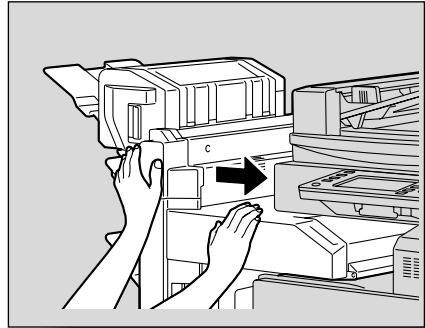

Detail

For details on the positions of paper misfeeds, refer to “Paper misfeed indications” on page 5-7.

To clear a paper misfeed in the mailbin

- 1 Open the front door.

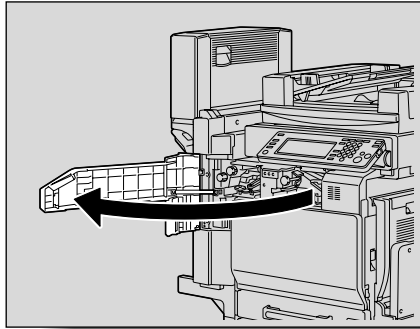

- 2 Turn dial FN5 or dial FN6 to feed out the paper.

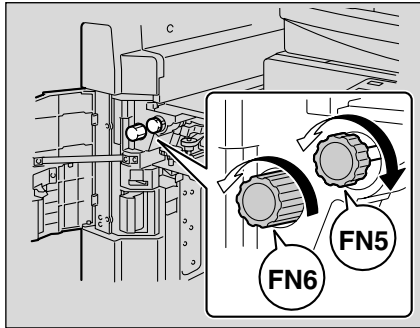

- 3 While pressing down lever FN7, pull out any paper.

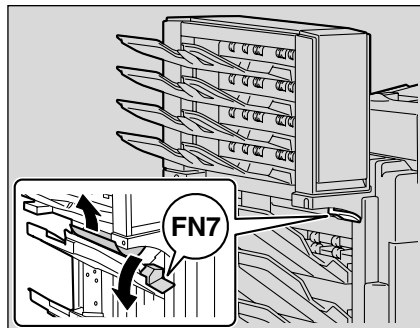

- 4 Pull handle FN8 to open the misfeed-clearing door.

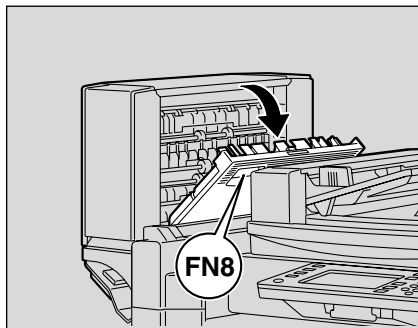

- 5 Pull out any paper in the mailbin.

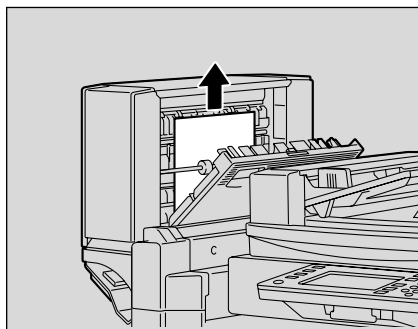

- 6 Close the misfeed-clearing door.

- 7 Close the front door.



Detail

For details on the positions of paper misfeeds, refer to "Paper misfeed indications" on page 5-7.

To clear a paper misfeed in the saddle stitcher

- 1 Open the front door.

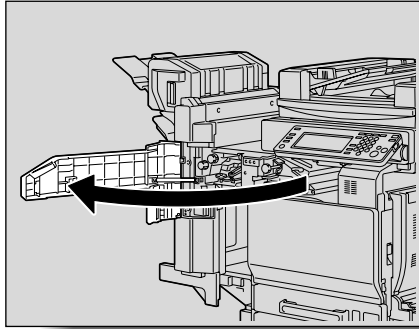

- 2 Turn dial FN5 or dial FN6 to feed out the paper.

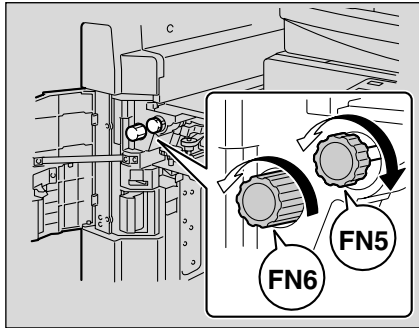

- 3 Remove all paper from the finishing tray.

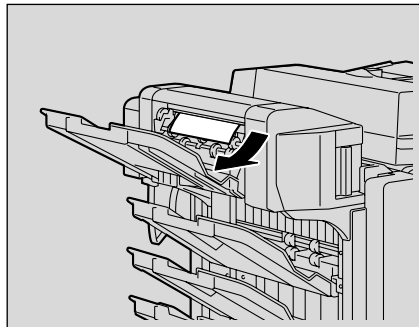

- 4 Open the misfeed-clearing door, and then pull out any paper.

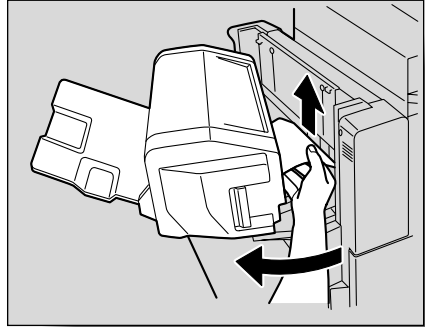

- 5 Close the misfeed-clearing door.
- 6 Close the front door.

**Detail**

For details on the positions of paper misfeeds, refer to “Paper misfeed indications” on page 5-7.

To clear a paper misfeed in finisher FS-501

- 1 Slide the finisher away from the machine.

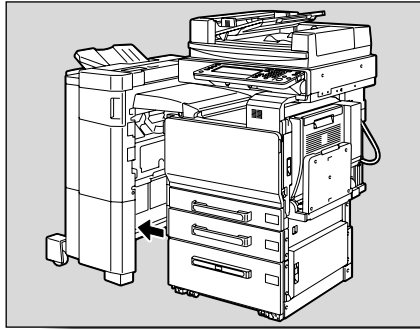

- 2 Open the horizontal transport unit cover, and then remove any misfed paper.

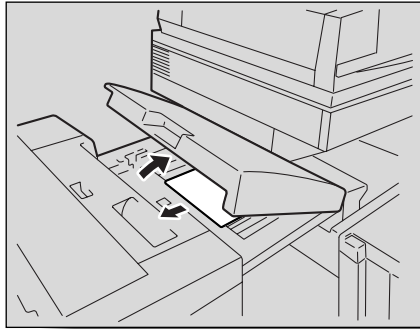

- 3 Close the horizontal transport unit cover.

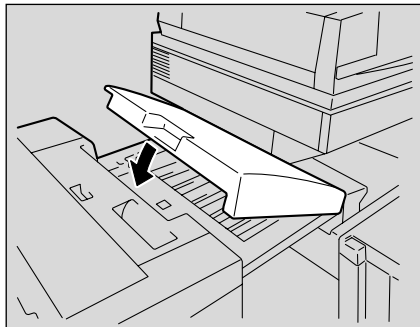

- 4 Open front door FN4.

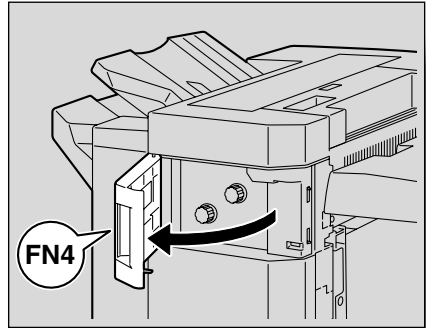

- 5 Turn misfeed-clearing dials FN5 clockwise at the same time.

? What should be done if the paper can be seen from the exit tray?

→ Turn misfeed-clearing dials FN5 counterclockwise at the same time to feed out any misfed paper.

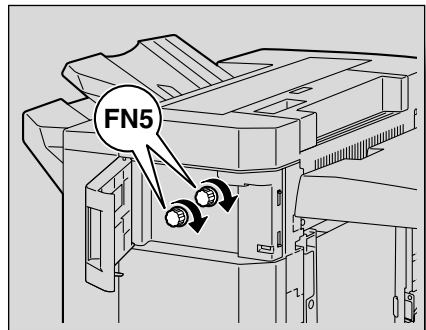

- 6 Close front door FN4.

- 7 While holding misfeed-clearing guide FN7 open, pull out any misfed paper.

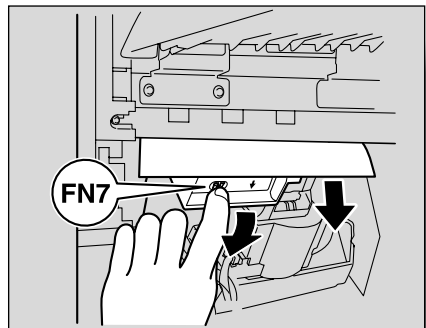

- 8 Open upper cover FN1.

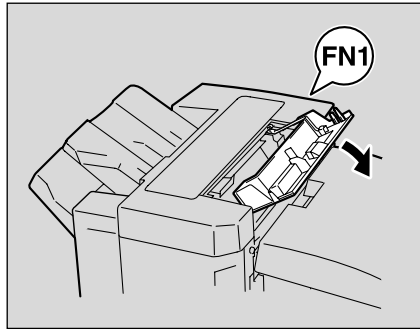

- 9 Open misfeed-clearing guide FN2, and then pull out any misfed paper.

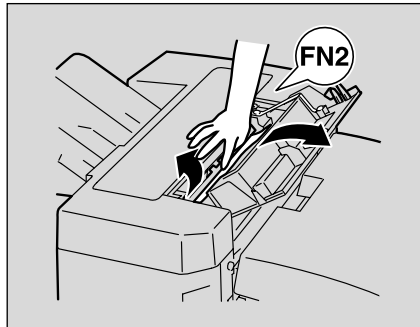

- 10 While holding misfeed-clearing guide FN3 open, pull out any misfed paper.

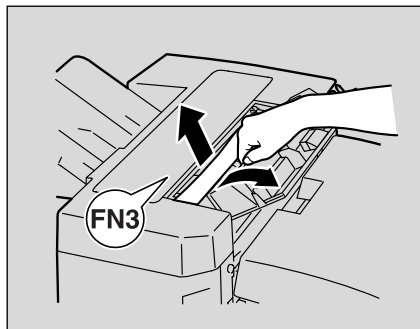

- 11 Close upper cover FN1.

- 12** If job separator JS-601 is installed:
 Open the job separator cover.
- If job separator JS-601 is not installed, skip to step 15.

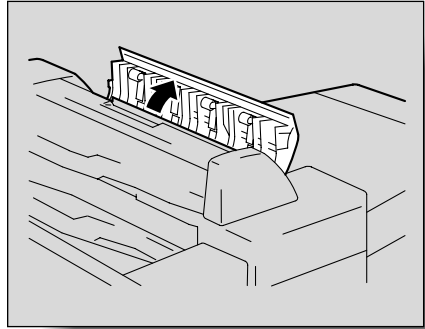

- 13** Remove any misfed paper.

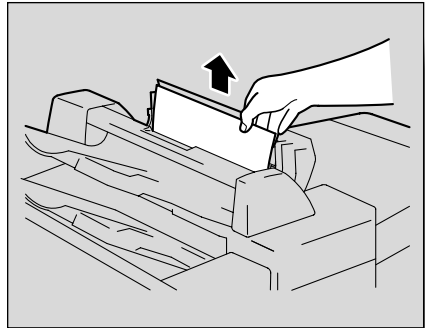

- 14** Close the job separator cover.

- 15** While holding misfeed-clearing guide FN6 open, pull out any misfed paper.

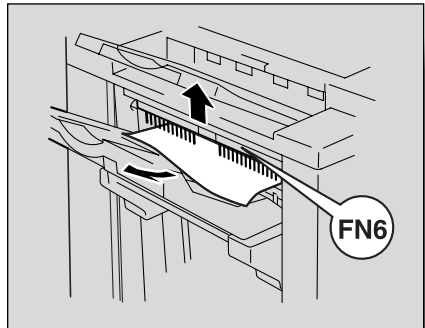

- 16** Slide the finisher back against the machine.



CAUTION

Metallic parts on the inside of the upper cover are very hot.



→Touching any part other than the paper may result in burns.



Detail

For details on the positions of paper misfeeds, refer to “Paper misfeed indications” on page 5-7.

To clear a paper misfeed in finisher FS-603

- 1 Slide the finisher away from the machine.

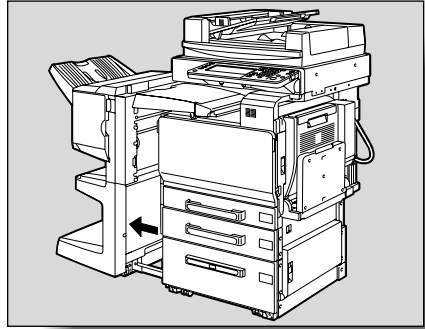

- 2 Open the horizontal transport unit cover, and then remove any misfed paper.

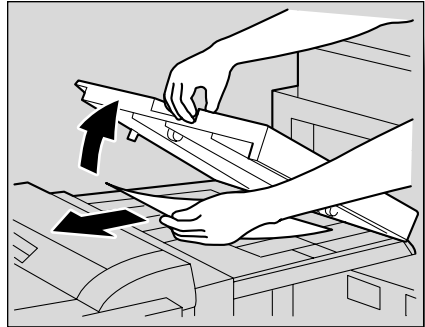

- 3 Close the horizontal transport unit cover.
- 4 Open the front door of the finisher.

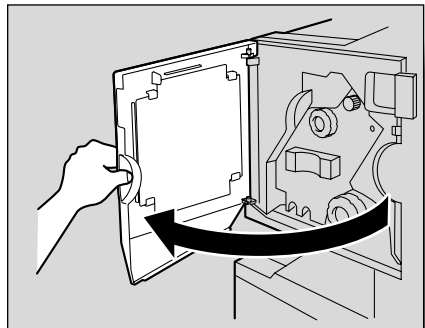

- 5 Turn misfeed-clearing dial 1 clockwise until the removal indicator is completely blue.

? What should be done if the misfeed-clearing dial 1 is turned too far?

- Turn the misfeed-clearing dial 1 counterclockwise to finely adjust it.

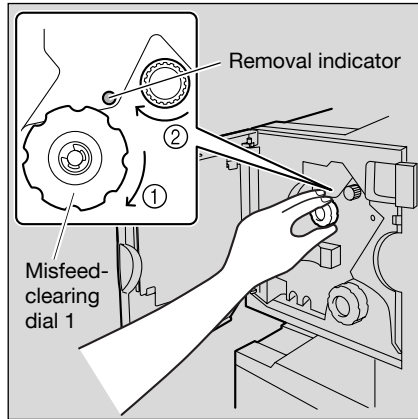

- 6 Open the upper door of the finisher, and then pull out any paper in the feed section.

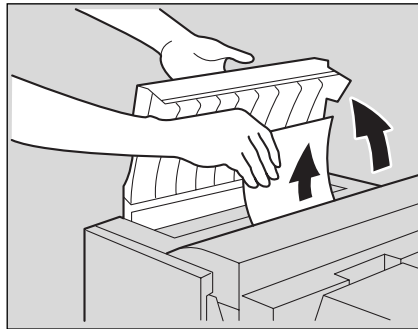

- 7 Close the upper door.
- 8 Remove all paper fed into the exit tray 1.

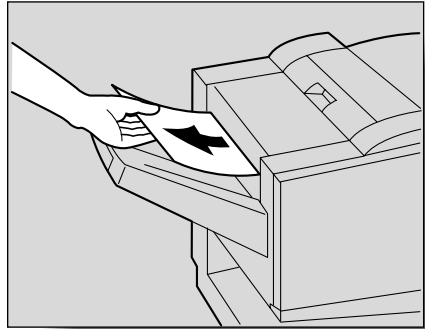

- 9 Open the misfeed-clearing guide for the finisher, and then remove any misfed paper.

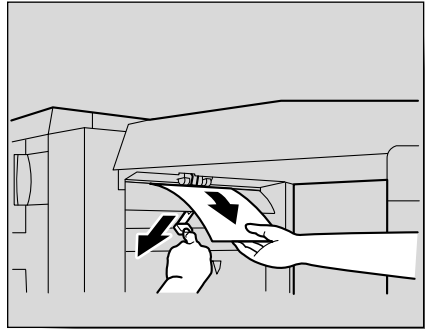

- 10 Open the right-side door, and then pull out any misfed paper in the transport section.

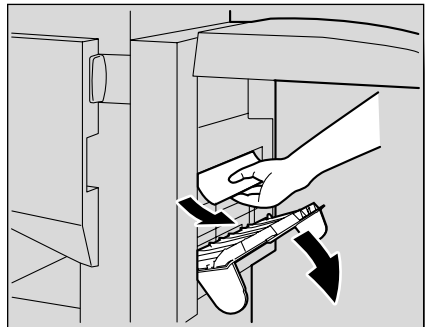

- 11** If the paper could not be removed in step 10, turn the misfeed-clearing dial in the folding section clockwise.

Feed the paper into the exit tray 2, and then pull it out.

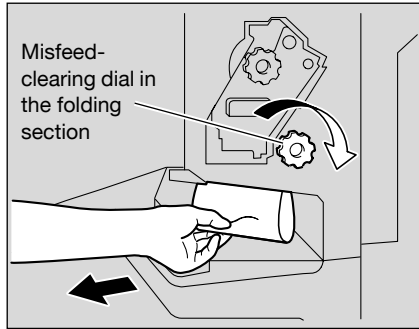

- 12** Close the front door of the finisher.

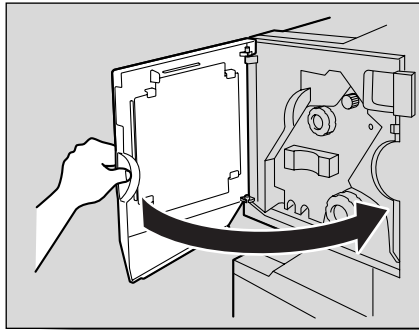

- 13** Slide the finisher back against the machine.



Reminder

If the message "Misfeed detected." appears, be sure to open the front door, turn the misfeed-clearing dial until the removal indicator is completely blue, and then remove the paper. If the paper is pulled out with too much force, the finisher may be damaged.

Do not pull paper remaining in the transfer unit out with too much force, otherwise the folding unit may be damaged.

Be careful that your fingers are not pinched when the front door is closed.

For details on the positions of paper misfeeds, refer to "Paper misfeed indications" on page 5-7.

5.3 When the message “Replenish paper.” appears

If a tray has run out of paper while copying or after printing, the message “Replenish paper.” appears.

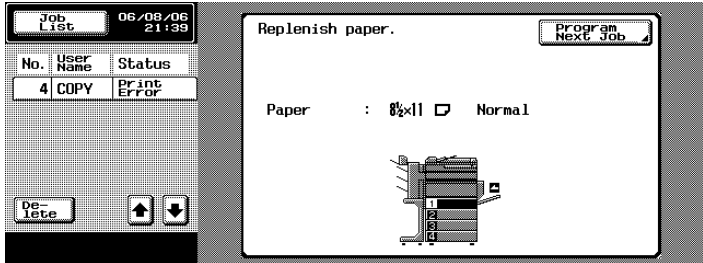

To replenish paper

- Check which paper tray appears highlighted in the touch panel, and then load it with paper.



Detail

For details on loading paper into the paper trays, refer to “Loading paper into the 1st tray” on page 2-47, “Loading paper into the 2nd, 3rd or 4th tray” on page 2-53, “Loading paper into the LCT” on page 2-55, and “Loading paper into the bypass tray” on page 2-58.

5.4 When the message "... Not enough remaining memory." appears

This machine uses the memory to produce copies.

When the amount of memory available is limited while copy operations are being performed, the message "Not enough memory to continue the job." or "The job has been deleted. Not enough remaining memory." appears.

Continue the operation according to the corresponding instructions.

Memory becomes full while scanning

This message appears when the memory becomes full and scanning stops while scanning in Copy mode.

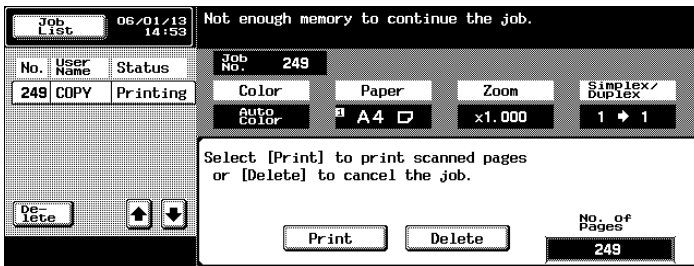

To print all pages that have been scanned, touch [Print].

To delete the job for the scanned pages, touch [Delete].

Display in Enlarge Display mode

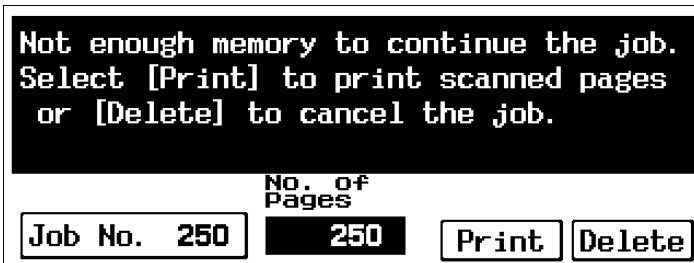

Memory becomes full while queuing a job

This message appears when the memory becomes full and the scanned job was deleted while scanning a document for a job to be queued.

Check the number of pages counted for the document, and then adjust the number of pages in the job to be queued.

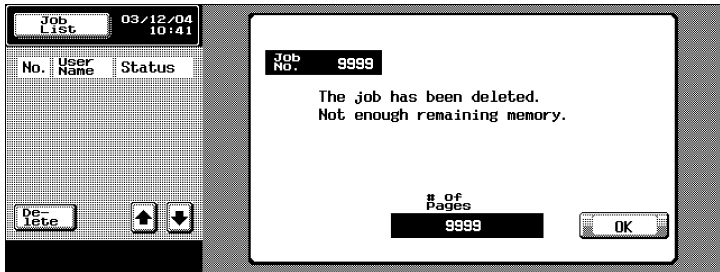

Display in Enlarge Display mode



5.5 When “Please replace following unit(s).” appears

When it is almost time to replace supplies or a part within this machine, the message shown in the following illustration appears, warning about the replacement period.

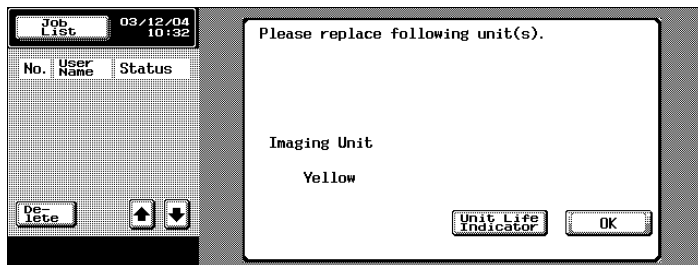

Display in Enlarge Display mode



Detail

When the message appears, replace the specified supplies or part according to your maintenance agreement.

After the message “Please replace following unit(s).”, the message “Need to replace XXXX.” appears and the machine stops operating.

The number of pages that can be printed from the time that the message “Please replace following unit(s).” appears until the time that the message “Need to replace XXXX.” appears differs depending on the printing conditions and the supplies or part.

5.6 When the message “Need to replace XXXX.” appears

When it is time to replace supplies or a part within this machine, the message shown in the following illustration appears, indicating that the part or supplies should be replaced, and the machine stops operating.

As an example, the message indicating that the yellow imaging unit should be replaced (when replaceable by the user) is shown below.



Display in Enlarge Display mode

When the time to replace supplies or a part is reached, a screen similar to the one shown below appears.



Touch  to display the message shown in the following illustration.

**Note**

When the message appears, replace the specified supplies or part according to your maintenance agreement.

**Reminder**

Do not throw away used supplies or parts. Instead, keep them in their boxes to be collected by your technical representative.

5.7 Simple troubleshooting

Main unit

Symptom	Possible Cause	Remedy
The machine does not start up when the main power switch is turned on.	Is no power supplied from the electrical outlet?	Correctly insert the power supply plug into the electrical outlet.
	Has the [Power] (auxiliary power) key been turned on?	Turn on the [Power] (auxiliary power) key.
The machine does not start copying.	Is the right-side door of the machine open?	Securely close the right-side door of the machine.
	Is there no paper that matches the document?	Load paper of the appropriate size into the paper tray.
The printed output is too light.	Is the copy density set too light?	Touch [Dark] in the Density screen to copy at the desired copy density. (See p. 3-60.)
	Is the paper damp?	Replace the paper with new paper. (See p. 2-47, p. 2-53, p. 2-55 and p. 2-58.)
The printed output is too dark.	Is the copy density set too dark?	Touch [Light] in the Density screen to copy at the desired copy density. (See p. 3-60.)
	Was the document not pressed close enough against the original glass?	Position the document so that it is pressed closely against the original glass. (See p. 3-9.)
The printed output is blurry.	Is the paper damp?	Replace the paper with new paper. (See p. 2-47, p. 2-53, p. 2-55 and p. 2-58.)
	Was the document not pressed close enough against the original glass?	Position the document so that it is pressed closely against the original glass. (See p. 3-9.)

Symptom	Possible Cause	Remedy
There are dark specks or spots throughout the printed output. There are streaks in the printed output.	Is the original glass dirty?	Wipe the glass with a soft, dry cloth. (See p. 10-3.)
	Is the document transfer belt dirty?	Clean the document transfer belt with a soft cloth dampened with a mild detergent. (See p. 10-4.)
	Was the original document printed on highly translucent material, such as diazo photosensitive paper or overhead projector transparencies?	Place a blank sheet of paper on top of the document. (See p. 3-9.)
	Is a double-sided document being copied?	If a thin double-sided document is being copied, the information on the back side may be reproduced in the copy. Touch [Light] on the Background Removal screen to select a lighter background density. (See p. 3-61.)
	Is the electrostatic charger wire dirty?	Use the charger-cleaning tool to clean the electrostatic charger. (See p. 10-6.)
The image is not aligned properly on the paper.	Is the document incorrectly positioned?	Correctly position the document against the document scales. (See p. 3-9.) Load the document into the ADF, and slide the adjustable document guides to fit the size of the document. (See p. 3-7.)
	Is the document incorrectly positioned in the ADF?	If the document cannot be fed correctly through the ADF, make copies by positioning the document on the original glass. (See p. 3-9.)
	Is the original glass dirty (while using the ADF)?	Wipe the glass with a soft, dry cloth. (See p. 10-3.)
	Are the adjustable document guides incorrectly positioned against the edges of the document?	Slide the document guides against the edges of the document.
	Was curled paper loaded into the paper tray?	Flatten the paper before loading it.
The printed page is curled.	Was paper that curls easily (as with recycled paper) used?	Remove the paper from the paper tray, turn it over, and then load it again. Replace the paper with paper that is not damp.

Symptom	Possible Cause	Remedy
The edge of the printed output is dirty.	Is the document transfer belt dirty?	Clean the document transfer belt with a soft cloth dampened with a mild detergent. (See p. 10-4.)
	Was the selected paper size larger than the document (with a Zoom setting of "×1.000")?	Select a paper size that is the same size as the document. Otherwise, select the "Auto Zoom" setting to enlarge the copy to the selected paper size. (See p. 3-38.)
	Is the orientation of the document different from the orientation of the paper (with a Zoom setting of "×1.000")?	Select a paper size that is the same size as the document. Otherwise, select a paper orientation that is the same as that of the document.
	Was the copy reduced to a size smaller than the paper (with a reduced zoom ratio specified)?	Select a zoom ratio that adjusts the document size to the selected paper size. (See p. 3-38.) Otherwise, select the "Auto Zoom" setting to reduce the copy to the selected paper size. (See p. 3-38.)
Even though the paper misfeed was cleared, copies cannot be produced.	Are there paper misfeeds at other locations?	Check the touch panel for other paper misfeed indications, and then remove any misfed paper at all other locations. (See "Paper misfeed indications" on page 5-7.)
Printing with the "2→1" or "2→2" Simplex/Duplex settings are not possible.	Have settings been selected that cannot be combined?	Check the combinations of the selected settings.
Copying is not possible even though the password is entered on a machine with user authentication/account track set.	Did the message "Your account has reached its maximum color-copy (black-copy) allowance." appear?	Contact your administrator.

ADF

Symptom	Possible Cause	Remedy
The document is not fed.	Is the ADF slightly open?	Securely close the ADF.
	Is the document one that does not meet the specifications?	Check that the document is correctly placed on the original glass.
	Is the document correctly loaded?	Position the document correctly. (See p. 3-7.)

Finisher

Symptom	Possible Cause	Remedy
The finisher cannot be used.	Is no power supplied to the connector?	Check that the cord is correctly inserted into the connector.
The pages cannot be stapled.	Have the staples run out?	Replace the staple cartridge. (See p. 9-10.)
The staple is incorrectly positioned by 90°.	Are the staples positioned as specified?	Select the desired position for the staples. (See p. 3-72.)
The pages that were fed out were not uniformly loaded and the punched holes or staples are incorrectly positioned.	Is the paper curled?	Remove the paper from the paper tray, turn it over, and then load it again.
	Is there a gap between the lateral guides in the paper tray and the side of the paper?	Slide the lateral guides in the paper tray against the side of the paper so that there is no gap.
Even though a Punch setting was selected, holes are not punched. (when punch kit is installed on finisher)	Did the message "Remove punch scraps." appear?	Empty the hole-punch waste container.

If any message other than those listed above appears, perform the operation described in the message.

If the problem is not corrected after the described operation is performed, contact your technical representative.

5.8 Main messages and their remedies

Message	Cause	Remedy
Original left on glass.	The document was left on the original glass.	Remove the document from the original glass.
Matching paper size is not available. Select paper size.	Paper of a suitable size is not loaded in a paper tray.	Either select a different copy size or load paper of a suitable size.
Place paper in Bypass Tray.	Paper of a suitable size is not loaded in the bypass tray.	Load paper of the appropriate size into the bypass tray.
Original size cannot be detected. Select paper size.	① The document is not positioned correctly. ② A document with a non-standard size or with a size too small to be detected is loaded.	① Position the document correctly. ② Select the correct paper size.
Image will not fit on selected paper size. Place the originals different direction.	The image does not fit in the paper.	Load the document turned 90°.
This mode is not available with XXX.	Functions that cannot be used together are selected.	Make copies using only one of the functions.
Output Tray has reached its maximum capacity. Please remove all pages from → tray.	Since the maximum amount of copies for the indicated finisher exit tray has been exceeded, the machine is unable to make copies.	Remove all copies from the indicated tray.
Input User Name and Password to login and press the Access key.	User authentication settings have been specified. Copies cannot be made unless a user name and its correct password are entered.	Type in your user name and password. (See "Controlling each user's use of this machine (user authentication)" on page 2-40.)
Input Account Name and Password to login and press the Access key.	Account track settings have been specified. Copies cannot be made unless an account name and its correct password are entered.	Type in your account name and password. (See "Controlling each account's use of this machine (account track)" on page 2-43.)
Your account has reached its maximum color-copy (black-copy) allowance.	The limit on the number of copies that can be made has been reached.	Contact your administrator.
Close → Section properly.	Since a machine door or cover is open or an option is not installed correctly, the machine is unable to make copies.	Make sure that all doors and covers are closed and that all options are installed correctly.

Message	Cause	Remedy
Please insert Fusing Unit and close all doors.	The fusing unit is not installed correctly.	Reinstall the supplies or parts, or contact your technical representative.
Please install toner cartridge, and close all doors.	The indicated toner cartridge is not installed correctly.	
Please insert Waste Toner Box and close all doors.	The waste-toner box is not installed correctly.	
Please insert Image Transfer Belt Unit and close all doors.	The image transfer belt unit is not installed correctly.	
Replenish paper.	The indicated tray has run out of paper.	Load paper into the indicated tray. (See "Loading paper into the 1st tray" on page 2-47, "Loading paper into the 2nd, 3rd or 4th tray" on page 2-53, "Loading paper into the LCT" on page 2-55, and "Loading paper into the bypass tray" on page 2-58.)
Toner cartridge (X) needs to be replaced soon.	The toner for the indicated color is about to run out.	Prepare to replace the toner cartridge according to your maintenance agreement.
There is no Toner.	Since the toner for the indicated color has run out, the machine is unable to make copies.	Replace the toner cartridge according to your maintenance agreement.
Stapler empty. Replace Staple Cartridge or cancel Staple mode.	The staples have run out.	Replace the staple cartridge. See "Replacing the staples" on page 9-10.
Misfeed detected.	Since a paper misfeed occurred, the machine is unable to make copies.	Clear the paper misfeed. (See "When the message "Misfeed detected." appears" on page 5-5.)
Reinsert the following # of originals.	After clearing a paper misfeed, it is necessary to reload certain pages of the document that have already been fed through the ADF.	Load the indicated document pages into the ADF.
Malfunction detected. Please call your Technical Representative.	The machine malfunctioned and is unable to make copies.	Inform your technical representative of the code displayed on the touch panel.
Now Downloading Program Data from Firmware server.	<ul style="list-style-type: none"> ① CS Remote Care was activated by the technical representative. ② Internet ISW is being downloaded. 	Do not turn off the machine with the [Power] (auxiliary power) key while this message is displayed. After turning off the machine with the [Power] (auxiliary power) key, turn off the main power switch, and then contact the technical representative.

Message	Cause	Remedy
Cannot be accessed due to unauthorized access. Please contact your Administrator.	The authentication information has become invalid since the authentication attempts have failed the specified number of times.	Contact the administrator of the machine.
The Administrator Password is not valid due to unauthorized access.	The administrator password has become invalid since the authentication attempts have failed the specified number of times.	Turn the machine off, then on again. Turn off the main power switch, and then wait about 10 seconds before turning it on again.

If any message other than those listed above appears, perform the operation described in the message.

6









Specifications





6 Specifications

6.1 Specifications

bizhub C252

Specifications	
Type	Desktop/freestanding scanner/printer
Document holder	Stationary (mirror scanning)
Photoconductor	OPC
Luminous source	White inert gas fluorescent lamp
Copying system	Dry-type electrophotographic method
Developing system	HMT developing method (HMT-OR)
Fusing system	Roller fixing
Resolution	Scanning: 600 dpi; Printing: 600 dpi × 600 dpi equivalent
Document	Types: Sheets, books (spreads), three-dimensional objects Size: Maximum 11 × 17 in (A3 in) Weight: 4-1/2 lb (three-dimensional objects)
Paper	Plain paper (16 to 24 lb)**, thick paper 1 (24-1/4 to 40 lb)*, thick paper 2 (40-1/4 to 55-1/2 lb)*, thick paper 3 (55-3/4 to 68 lb)*, overhead projector transparencies*, letterheads, colored paper, envelopes*, label sheets*, banner paper (33-3/4 to 42-1/2 lb) * Can only be fed through the 1st tray or the bypass tray ** Can only be fed through the bypass tray.
Copy sizes	1st tray: 11 × 17 in to 5-1/2 × 8-1/2 in, 4 × 6 in, A3 in to A5 in, B6 in, 12-1/4 × 18 in (A3 wide), 8 × 13 in ¹ Width: 3-1/2 to 12-1/4; Length: 5-1/2 to 18 2nd tray: 11 × 17 in to 8-1/2 × 11 in, A3 in to B5 in Bypass tray: 11 × 17 in to 5-1/2 × 8-1/2 in, 4 × 6 in, Banner paper, A3 in to B6 in, 12-1/4 × 18 in (A3 Wide), 8 × 13 in ¹ Width: 3-1/2 to 12-1/4; Length: 5-1/2 to 47-1/4

Specifications	
Paper tray capacity	1st tray: Plain paper: 250 sheets Thick paper 1/2/3, overhead projector transparencies, label sheets, envelopes: 20 sheets or less 2nd tray: Plain paper: 500 sheets Bypass tray: Plain paper: 100 sheets Thick paper 1/2/3, overhead projector transparencies, label sheets: 20 sheets or less Envelopes: 10 sheets or less Banner paper: 1 sheet
Copy exit tray capacity	Plain paper: 350 sheets; Thick paper: 20 sheets; Overhead projector transparencies: 1 sheet
Warm-up time	Less than 110 seconds (at room temperature (73.4°F))
Image loss width	Leading edge: 3/16; Trailing edge: 3/16 ³ ; Rear edge: 1/8 ⁴ ; Front edge: 1/8 ⁴
First copy	Full color: 11.7 seconds or less Black: 8.4 seconds or less
Print speed	Full color/black: 13 ppm (11 × 17 ) , 14 ppm (8-1/2 × 14 ) , 25 ppm (8-1/2 × 11 ) , 16 ppm (8-1/2 × 11 ) , 25 ppm (7-1/4 × 10-1/2 ) , 14 ppm (7-1/4 × 10-1/2 ) , 25 ppm (5-1/2 × 8-1/2 ) , 19 ppm (5-1/2 × 8-1/2 ) (using the 1st tray)
Magnification ratios	×1.0 (full size): ×1.000 ± 1.0% or less Enlarge: ×1.214, ×1.294, ×1.545, ×2.000 Reduce: ×0.785, ×0.733, ×0.647, ×0.500 Minimal (×0.930)* Zoom: ×0.250 to ×4.000 (in 0.001 increments) Stored zoom ratios: 3 * "Minimal" zoom ratio (×0.900 to × 0.999)
Multiple copies	1 to 999 sheets
Density control	Copy density: Manual (9 levels); Background density: Automatic and manual (9 levels)
Power requirements	120 to 127 V, 13.2 A, 60 Hz
Power consumption	Less than 1,500 W
Dimensions	25-1/2 (W) × 29-3/4 (D) × 30-1/4 (H)
Space requirements ^{*2}	68-1/2 (W) × 45-1/4 (D)
Memory (available hard disk space)	512 MB (40 GB)
Weight	Approx. 209-1/4 lb

*1 There are five Foolscap sizes: 220 mm × 330 mm, 8-1/2 × 13 , 8-1/4 × 13 , 8-1/8 × 13-1/4  and 8 × 13 . Any one of these sizes can be selected. For details, contact the technical representative.

*2 The indicated space requirements represent the space required to pull away the finisher and to open the upper right-side door, front door and the paper drawers.









*3 1/8 only when receiving faxes





*4 3/16 only when printing

In order to incorporate improvements, these product specifications are subject to change without notice.

Option specifications

Automatic duplex unit AD-503

Specifications	
Paper types	Plain paper (17 to 24 lb), thick paper 1 (24-1/4 to 40 lb), thick paper 2 (40-1/4 to 55-1/2 lb), thick paper 3 (55-3/4 to 68 lb)
Paper sizes	11 × 17  to 5-1/2 × 8-1/2  , A3  to A5  , 12 × 18  (A3 Wide), 8 × 13  *, 8K  , 16K  Width: 5-1/2 to 12-1/4; Length: 5-3/4 to 18
Power requirements	Supplied from main unit
Power consumption	Less than 17 W
Dimensions	4-1/4 (W) × 17-1/4 (D) × 13-1/2 (H)
Weight	Approx. 6-1/2 lb

* There are five Foolscap sizes: 220 mm × 330 mm , 8-1/2 × 13 , 8-1/4 × 13 , 8-1/8 × 13-1/4  and 8 × 13 . Any one of these sizes can be selected. For details, contact the technical representative.

Automatic document feeder DF-601



Specifications	
Document feed methods	Plain paper: Single-sided and double-sided documents Thick paper: Single-sided documents (34-1/4 to 55-3/4 lb) “Mixed Original” function: Combination of single-sided and double-sided documents
Document types	Single-sided: Plain paper (9-1/4 to 55-3/4 lb) Double-sided or mixed: Plain paper (13-1/4 to 29-1/4 lb)
Document sizes	Single-sided/double-sided documents: 11 × 17  to 5-1/2 × 8-1/2  Mixed document sizes: Refer to Table 1.
Capacity of document feeder	Single-sided/double-sided documents: Maximum 100 sheets (21-1/4 lb) Thick originals: Maximum 38 sheets (55-3/4 lb) Mixed document sizes: Maximum 100 sheets (21-1/4 lb)
Power requirements	Supplied from main unit
Power consumption	Less than 60 W
Dimensions	23 (W) × 20-1/2 (D) × 5-1/4 (H)
Weight	Approx. 30-3/4 lb





Table 1: Possible combinations for mixed document sizes

Maximum Document Width → ↓ Document Size	11 x 17 ☐	8-1/2 x 11 ☐	8-1/2 x 14 ☐	8-1/2 x 11 ☐	5-1/2 x 8-1/2 ☐	5-1/2 x 8-1/2 ☐
11 x 17 ☐	○	○	—	—	—	—
8-1/2 x 11 ☐	○	○	—	—	—	—
8-1/2 x 14 ☐	○	○	○	○	○	—
8-1/2 x 11 ☐	○	○	○	○	○	—
5-1/2 x 8-1/2 ☐	—	—	○	○	○	—
5-1/2 x 8-1/2 ☐	—	—	—	—	—	○





○: Possible

—: Not possible

Paper feed cabinet PC-103

Specifications	
Paper types	Plain paper (16 to 24 lb)
Paper sizes	11 × 17  to 5-1/2 × 8-1/2  , A3  to B5 
Tray paper capacity	3rd tray: 500 sheets (21-1/4 lb)
Power requirements	Supplied from main unit
Power consumption	Less than 15 W
Dimensions	22-1/2 (W) × 21-1/2 (D) × 10-1/4 (H)
Weight	Approx. 52-3/4 lb
Unit structure	1 paper tray













Paper feed cabinet PC-203

Specifications	
Paper types	Plain paper (16 to 24 lb)
Paper sizes	11 × 17  to 5-1/2 × 8-1/2  , A3  to B5 
Tray paper capacity	Upper tray (3rd tray): 500 sheets (21-1/4 lb) Lower tray (4th tray): 500 sheets (21-1/4 lb)
Power requirements	Supplied from main unit
Power consumption	Less than 15 W
Dimensions	22-1/2 (W) × 21-1/2 (D) × 10-1/4 (H)
Weight	Approx. 61-3/4 lb
Unit structure	2 paper trays





Paper feed cabinet PC-403

Specifications	
Paper types	Plain paper (16 to 24 lb)
Paper sizes	8-1/2 × 11 
Tray paper capacity	2,500 sheets (21-1/4 lb)
Power requirements	Supplied from main unit
Power consumption	Less than 45 W
Dimensions	22-1/2 (W) × 21-1/2 (D) × 10-1/4 (H)
Weight	Approx. 61-3/4 lb



Finisher FS-514

Specifications	
Finishing trays	Finishing tray 1, finishing tray 2
Feed settings	“Sort”, “Group”, “Sort”/“Offset”, “Group”/“Offset”, and “Sort” and Staple
Paper types	Finishing tray 1, finishing tray 2: Plain paper (13-1/4 to 24 lb) Thick paper (24-1/4 to 68 lb), overhead projector transparencies, postcards, envelopes, label sheets, letterheads Punch settings: Plain paper (13-1/4 to 55-1/2 lb) Staple settings: Plain paper (13-1/4 to 24 lb), thick paper (24-1/4 to 32 lb)* *“Cover Mode” function: Thick paper (24-1/4 to 55-1/2 lb)
Paper sizes	11 × 17  , 8-1/2 × 11  , 5-1/2 × 8-1/2  , 12-1/4 × 18  (A3 Wide )
Paper capacity	Output tray 1: Plain paper (13-1/4 to 24 lb): 200 sheets Thick paper (24-1/4 to 68 lb), overhead projector transparencies, postcards, envelopes, or label sheets, letterheads: 20 sheets Output tray 2: Plain paper (13-1/4 to 24 lb): 1,000 sheets of 8-1/2 × 11  or smaller, or 500 sheets of 8-1/2 × 14  or larger Thick paper (24-1/4 to 68 lb), overhead projector transparencies, postcards, envelopes, or label sheets, letterheads: 20 sheets
Amount of shift	1-1/4
Staple settings	Paper sizes (no. of bound pages): 11 × 17  to 8-1/2 × 11  (2 to 50 sheets)
Punch settings	Paper sizes: 2-hole: 11 × 17  to 8-1/2 × 11  3-hole: 11 × 17  , 8-1/2 × 11  Number of punched holes: 2, 3
Power requirements	Supplied from main unit
Power consumption	Less than 66 W
Dimensions	13-3/4 (W) × 18-1/2 (D) × 22-1/2 (H) When the tray is pulled out: 17-1/4 (W)
Weight	73-1/4 lb
Consumables	Staples SK-602 (containing 5,000 staples) × 1

Punch kit PK-510

Specifications	
Punched holes	2, 3
Paper types	Plain paper (13-1/4 to 55-1/2 lb)
Paper sizes	2-hole: 11 × 17  to 8-1/2 × 11  3-hole: 11 × 17  , 8-1/2 × 11 
Power requirements	Supplied from finisher
Dimensions	4-1/2 (W) × 18-1/4 (D) × 4-1/4 (H)
Weight	Approx. 4-1/4 lb

Saddle stitcher SD-503

Specifications	
Number of bins	1 bin
Paper types	Plain paper (13-1/4 to 24 lb), thick paper (24-1/4 to 55-1/2 lb)
Paper sizes	11 × 17  , 8-1/2 × 11 
Paper capacity	Plain paper (13-1/4 to 24 lb): Maximum 200 sheets or 20 sets
Staple settings	Number of bound pages: 2 to 15 sheets
Dimensions	17-1/2 (W) × 8 (D) × 18-3/4 (H) When the tray is pulled out: 22-3/4 (W) × 11 (D)
Weight	16-1/4 lb
Consumables	MS-2C cartridge (for 2,000) × 1
Power requirements	Supplied from finisher

















Output tray OT-601

Specifications	
Number of bins	1 bin
Paper capacity	Plain paper (13-1/4 to 24 lb): Maximum 200 sheets Thick paper (24-1/4 to 68 lb), postcards, envelopes, overhead projector transparencies, or label sheets, letterheads: Maximum 20 sheets
Dimensions	11 (W) × 14-1/2 (D) × 2-1/4 (H)
Weight	1-1/2 lb

Mailbin kit MT-501





Specifications	
Number of bins	4 bins
Paper types	Plain paper (13-1/4 to 24 lb)
Paper sizes	8-1/2 × 11 □, 5-1/2 × 8-1/2 □
Paper capacity	Maximum 125 sheets per bin
Dimensions	13-1/2 (W) × 20 (D) × 15-1/4 (H)
Weight	Approx. 17-1/2 lb (unit weight)
Power requirements	Supplied from finisher

Finisher FS-603









Specifications	
Exit trays	Exit tray 1, exit tray 2
Settings	Normal settings: "Group", "Sort", "Offset/Group", "Offset/Sort", "Offset/Staple", and "Saddle Staple"
Paper types	Exit tray 1: "Group/Sort" setting: Plain paper (16 to 24 lb), thick paper 1 (24-1/4 to 40 lb), thick paper 2 (40-1/4 to 55-1/2 lb), thick paper 3 (55-3/4 to 68 lb), envelopes, overhead projector transparencies, label sheets "Offset/Sort" setting, "Offset/Group" setting: Plain paper (16 to 24 lb) Staple: Plain paper (16 to 24 lb) Exit tray 2: Plain paper (16 to 24 lb)
Paper sizes	Exit tray 1: "Group" setting: 11 × 17  to 5-1/2 × 8-1/2  , 12-1/4 × 18  (A3 Wide) "Sort" setting: 11 × 17  to 5-1/2 × 8-1/2  "Staple" setting: 11 × 17  to 8-1/2 × 11  Exit tray 2: 11 × 17  , 8-1/2 × 11 
Paper capacity	Exit tray 1: Plain paper (16 to 24 lb): 1,000 sheets of 8-1/2 × 11  -size paper or smaller, or 500 sheets of 8-1/2 × 14  -size paper or larger Thick paper 1 (24-1/4 to 40 lb), thick paper 2 (40-1/4 to 55-1/2 lb), thick paper 3 (55-3/4 to 68 lb), envelopes, overhead projector transparencies, label sheets: 20 sheets Exit tray 2: 10 copies (6 to 15 bound pages)* 20 copies (2 to 5 bound pages)
Amount of shift	13/16
Staple settings	Exit tray 1: Paper sizes (no. of bound pages): 8-1/2 × 11  ,  (2 to 50 pages), 11 × 17  , 8-1/2 × 14  (2 to 25 pages) Exit tray 2: Paper sizes (no. of bound pages): 11 × 17  , 8-1/2 × 11  (2 to 15 pages)
Power requirements	Supplied from main unit
Power consumption	Less than 65 W
Dimensions	23-1/4 (W) × 23-3/4 (D) × 38-3/4 (H)
Weight	Approx. 92-1/2 lb (including the horizontal transport unit)
Consumables	Staples MS-5D (5,000 staples for stapling 50 sheets) × 1

* The number of pages that can be bound together differs depending on the paper weight. If 17 lb paper is used, 6 to 15 pages can be bound together. If 21-1/4 lb paper is used, 6 to 10 pages can be bound together.

Punch kit PK-501



Specifications	
Number of punched holes	2, 3
Paper types	Plain paper (16 to 14 lb), thick paper 1 (24-1/4 to 40 lb), thick paper 2 (40-1/4 to 55-1/2 lb)
Paper sizes	2-hole: 11 × 17  to 8-1/2 × 11  3-hole: 11 × 17  8-1/2 × 11 
Power requirements	Supplied from finisher
Dimensions	3-1/2 (W) × 22 (D) × 6-3/4 (H)
Weight	Approx. 6-1/2 lb

Finisher FS-501

Specifications	
Exit trays	Exit tray 1, exit tray 2
Settings	"Sort", "Group", "Offset/Sort", "Offset/Group", and Staple settings
Paper types	Exit tray 1: "Group" setting: Plain paper (16 to 24 lb), thick paper 1 (24-1/4 to 40 lb), thick paper 2 (40-1/4 to 55-1/2 lb), thick paper 3 (55-3/4 to 68 lb), overhead projector transparencies, postcards, envelopes, label sheets Exit tray 2: "Sort", "Group", "Offset/Sort", "Offset/Group" settings: Plain paper (16 to 24 lb), thick paper 1 (24-1/4 to 40 lb), thick paper 2 (40-1/4 to 55-1/2 lb) Staple settings: Plain paper (16 to 24 lb)
Paper sizes	Exit tray 1: 11 × 17  to 5-1/2 × 8-1/2  12-1/4 × 18 (A3 wide) Exit tray 2: 11 × 17  to 7-1/4 × 10-1/2  12-1/4 × 18 (A3 wide)
Paper capacity	Exit tray 1: Plain paper (16 to 24 lb): 250 sheets Thick paper 1/2/3 (24-1/4 to 68 lb), overhead projector transparencies, envelopes, label sheets, postcards: 20 sheets Exit tray 2: Plain paper (21-1/4 lb): 1,000 sheets of 8-1/2 × 11  or smaller, or 500 sheets of 8-1/2 × 14  or larger
Amount of shift	1-3/16
Staple settings	Paper sizes (no. of bound pages): 11 × 17  to 7-1/4 × 10-1/2  (2 to 30 sheets)
Power requirements	Supplied from main unit
Power consumption	Less than 63 W
Dimensions	21-1/4 (W) × 25 (D) × 38-1/2 (H)
Weight	Approx. 83-3/4 lb (including the horizontal transport unit)

Specifications	
Consumables	Staples MS-3C (3,000 staples for stapling 30 sheets) × 1

Job separator JS-601

Specifications	
Exit trays	Exit tray 3:
Paper types	Plain paper (16 to 24 lb)
Paper sizes	11 × 17  to 5-1/2 × 8-1/2 
Paper capacity	100 sheets
Dimensions	13-1/2 (W) × 20-3/4 (D) × 5-3/4 (H)
Weight	Approx. 4-1/2 lb



Copy paper/original documents

7 Copy paper/original documents

7.1 Copy paper

Use paper that meets the following specifications.













































Possible paper sizes

































Non-standard-sized paper:





Paper Source	Paper Width	Paper Length
Bypass tray*	3-1/2 in. to 12-1/4 in.	5-1/2 in. to 47-1/4 in.
1st tray	3-1/2 in. to 12-1/4 in.	5-1/2 in. to 18 in.
2nd tray	—	—
Single/Double paper feed cabinets		
LCT		
Double-sided copies	5-1/2 in. to 12-1/4 in.	5-3/4 in. to 18 in.

* Banner paper
 Paper width: 8-1/4 in. to 11-3/4 in.
 Paper length: 18 in. to 47-1/4 in.

Standard-sized paper:

Paper Source	Paper Size
Bypass tray	11 × 17  to 5-1/2 × 8-1/2  , 4 × 6  , 8 × 13  ¹ , 12-1/4 × 18  (A3 Wide), A3  to B6 
1st tray	11 × 17  to 5-1/2 × 8-1/2  , 4 × 6  , 8 × 13  ¹ , 12-1/4 × 18  (A3 Wide), A3  to A5  , B6 
2nd tray	11 × 17  to 8-1/2 × 11  , A3  to B5 
Single/Double paper feed cabinets	11 × 17  to 5-1/2 × 8-1/2  , A3  to B5 
LCT	8-1/2 × 11 
Double-sided copies	11 × 17  to 5-1/2 × 8-1/2  , 8-1/2 × 13  ¹ , 12-1/4 × 18  (A3 Wide), A3  to A5 
Finisher FS-514	Finishing tray 1, 2 and optional Output Tray
Output Tray OT-601	11 × 17  , 8-1/2 × 11  , 5-1/2 × 8-1/2  , 12-1/4 × 18  (A3 wide ) “Group”/“Sort” settings: 11 × 17  to 8-1/2 × 11  Staple settings: 11 × 17  to 8-1/2 × 11  Punch settings ² : 2-hole: 11 × 17  to 8-1/2 × 11  3-hole: 11 × 17  , 8-1/2 × 11 
Saddle Stitcher SD-503	Fold & staple: 11 × 17  , 8-1/2 × 11 



Paper Source	Paper Size
Mailbin Kit MT-501	8-1/2 × 11  , 5-1/2 × 8-1/2 
Finisher FS-603	Exit tray 1: “Group” setting: 11 × 17  to 5-1/2 × 8-1/2   , 12-1/4 × 18  (A3 Wide) “Sort” setting: 11 × 17  to 5-1/2 × 8-1/2  “Staple” setting: 11 × 17  to 8-1/2 × 11   Exit tray 2: 11 × 17  , 8-1/2 × 11 
Finisher FS-501	Exit tray 1: “Group”/“Sort” setting: 11 × 17  to 5-1/2 × 8-1/2   , 12-1/4 × 18  (A3 Wide) Exit tray 2: “Offset/Group” setting, “Offset/Sort” setting: 11 × 17  to 7-1/4 × 10-1/2   , 12-1/4 × 18  (A3 Wide) “Staple” setting: 11 × 17  to 7-1/4 × 10-1/2  
Job separator JS-601	11 × 17  to 5-1/2 × 8-1/2 
Copy exit tray (standard)	11 × 17  to 5-1/2 × 8-1/2   , 12-1/4 × 18  (A3 Wide), A3  to B6  , A6  ,

*1 There are five Foolscap sizes: 220 × 330 mm, 8-1/2 × 13 , 8-1/4 × 13 , 8-1/8 × 13-1/4  and 8 × 13 . Any one of these sizes can be selected. For details, contact the technical representative.

*2 Can be used when optional punch kit is installed on finisher.







Paper types and paper capacities







Paper Type	Plain Paper	Thick Paper 1	Thick Paper 2	Thick Paper 3
Weight (lb)	16 lb to 24 lb	24-1/4 lb to 40 lb	40-1/4 lb to 55-1/2 lb	55-3/4 lb to 68 lb
Paper Source, Etc.				
Bypass tray	100 sheets	20 sheets or less	20 sheets or less	20 sheets or less
1st tray	250 sheets	20 sheets or less	20 sheets or less	20 sheets or less
2nd tray	500 sheets	—	—	—
Single/Double paper feed cabinets	500 sheets/ 1,000 sheets	—	—	—
LCT	2,500 sheets	—	—	—
Double-sided copies	○	○	○	○

Paper Type	Overhead Projector Transparencies	Postcards	Envelopes	Label Sheets	Banner Paper
Paper Source, Etc.					33-3/4 lb to 42-1/2 lb
Bypass tray	20 sheets or less (8-1/2 × 11  only)	20 sheets or less	20 envelopes or less	20 sheets or less	1 sheet
1st tray	20 sheets or less (8-1/2 × 11  only)	20 sheets or less	10 envelopes or less	20 sheets or less	—
2nd tray	—	—	—	—	—
Single/Double paper feed cabinets	—	—	—	—	—
LCT	—	—	—	—	—
Double-sided copies	—	—	—	—	—

Special paper

Paper other than plain paper, such as overhead projector transparencies and colored paper, is called special paper. Be sure to select a special paper setting for paper trays loaded with media such as overhead projector transparencies and colored paper in order to prevent operating errors.

Paper Type		Icon	Description
Plain Paper	Single Side Only		Select this setting when paper that should not be used with double-sided copying (for example, when one side has already been printed on) is loaded as plain paper with a weight of 16 lb to 24 lb. A paper tray with this setting is given priority when the "Auto Paper Select" setting is specified. A paper tray with this setting is not automatically selected during double-sided copying.
	Special Paper		Select this setting when special paper, for example, high-quality paper, is loaded as plain paper with a weight of 16 lb to 24 lb. A paper tray with this setting is not automatically selected when the "Auto Paper Select" setting is specified or when the paper trays are switched automatically.
	Letterhead		Select this setting when paper already printed with a company name or preset text is loaded as plain paper with a weight of 16 lb to 24 lb. A paper tray with this setting is not automatically selected when the "Auto Paper Select" setting is specified or when the paper trays are switched automatically.
	Colored Paper		Select this setting when colored paper is loaded as plain paper with a weight of 16 lb to 24 lb. A paper tray with this setting is not automatically selected when the "Auto Paper Select" setting is specified or when the paper trays are switched automatically.
OHP			Select this setting when overhead projector transparencies are loaded. A paper tray with this setting is not automatically selected when the "Auto Paper Select" setting is specified or when the paper trays are switched automatically.
Thick 1			Select this setting when the thick paper that is loaded has a weight of 24-1/4 lb to 40 lb. A paper tray with this setting is not automatically selected when the "Auto Paper Select" setting is specified or when the paper trays are switched automatically.
Thick 2			Select this setting when the thick paper that is loaded has a weight of 40-1/4 lb to 55-1/2 lb. A paper tray with this setting is not automatically selected when the "Auto Paper Select" setting is specified or when the paper trays are switched automatically.

Paper Type		Icon	Description
Thick 3			Select this setting when the thick paper that is loaded has a weight of 55-3/4 lb to 68 lb. A paper tray with this setting is not automatically selected when the "Auto Paper Select" setting is specified or when the paper trays are switched automatically.
Envelope			Select this setting when envelopes are loaded. A paper tray with this setting is not automatically selected when the "Auto Paper Select" setting is specified or when the paper trays are switched automatically.
Duplex 2nd- Side	Normal		Select these settings when loading paper that has already been printed on one side. "Duplex 2nd-Side" can be selected only normal, thick 1, thick 2 or thick 3 paper is loaded in the 1st tray or the bypass tray.
	Thick 1		
	Thick 2		
	Thick 3		

Precautions for paper

The following types of paper should not be used, otherwise decreased print quality, paper misfeeds or damage to the machine may occur.

- Overhead projector transparencies that have already been fed through the machine (even if the transparency is still blank)
- Paper that has been printed on by a heat-transfer printer or an inkjet printer
- Paper that is either extremely thick or extremely thin
- Folded, curled, wrinkled, or torn paper
- Paper that has been left unwrapped for a long period of time
- Damp paper, perforated paper, or paper with punched holes
- Extremely smooth or extremely rough paper, or paper with an uneven surface
- Paper that has been treated, such as carbon-backed, heat-sensitive or pressure-sensitive paper
- Paper that has been decorated with foil or embossing
- Paper of a non-standard shape (not rectangular)
- Paper that is bound with glue, staples or paper clips
- Paper with labels attached
- Paper with ribbons, hooks, buttons, etc. attached

Paper storage

Observe the following precautions when storing the paper.

- Store paper in a cool, dark location with little humidity.
- If the paper becomes damp, paper misfeeds may occur.
Paper that has not been loaded should be kept wrapped or placed in a plastic bag and stored in a cool, dark location with little humidity.
- Store the paper laying flat, not standing on its edge. Curled paper may cause paper misfeeds.
- Keep paper out of the reach of children.

Auto tray switch feature

If the selected paper tray runs out of paper while a job is being printed and a different paper tray is loaded with paper meeting the following conditions, the other paper tray is automatically selected so printing can continue. If the optional LCT is installed, a maximum of 3,400 copies (with 8-1/2 × 11  paper) can be made continuously. (The paper tray is automatically switched only if the “Auto Tray Switch ON/OFF” parameter in the Utility mode is set to “Allow”.)

Operating Conditions

- The paper is the same size.
- The paper is positioned in the same orientation.
- The paper is the same type.
- Paper trays that are selected when the paper tray is automatically switched.



Detail

For details on the specifying the paper trays that are selected when the paper tray is automatically switched, refer to “System setting” on page 12-17.

Order for Selecting the Paper trays

As a factory default, when a different paper tray is automatically selected, the next paper tray in the following list is chosen.

2nd tray → 3rd tray → 4th tray → 1st tray



Detail

To change the order in which the paper trays are selected, refer to “System setting” on page 12-17.

7.2 Selecting the paper settings

This section describes the procedures for specifying the size and type of paper loaded in each paper tray.



Detail

For details on loading the paper into the 1st tray, refer to “Loading paper into the 1st tray” on page 2-47.

For details on loading the paper into the bypass tray, refer to “Loading paper into the bypass tray” on page 2-58.

To automatically detect the paper size (“Auto Paper Select” setting)

The size of the paper loaded into the 1st tray and the bypass tray can be detected automatically.

The following procedure describes how to specify the setting for automatically detecting the paper loaded into the 1st tray.

- 1 In the Basic screen, touch [Paper].

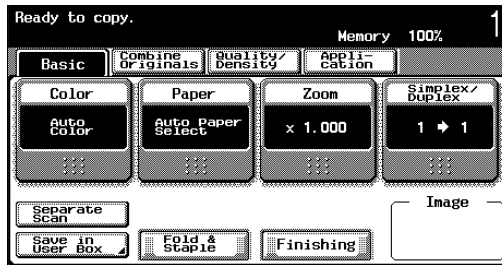

The Paper screen appears.

- 2 Touch the button for the 1st tray.
 - To specify automatic detection for the bypass tray, touch the button for the bypass tray.

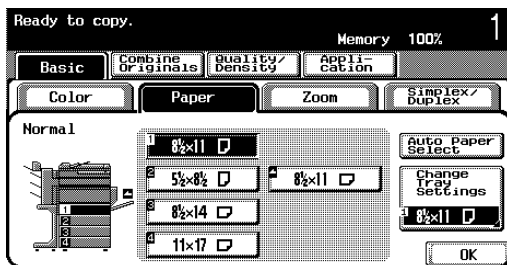

- 3 Touch [Change Tray Settings].
- 4 Touch [Auto Detect].

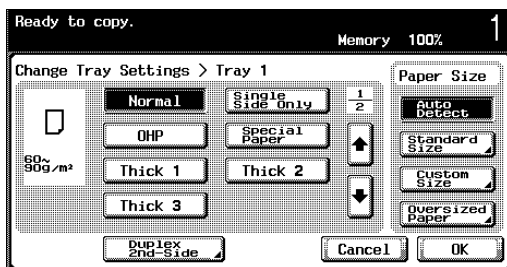

As a default, “Auto Detect” is selected.

- 5 Touch [OK], and then touch [OK] in the next screen that appears. The Basic screen appears again.

To specify a paper size (set size settings)

The paper size for the 1st tray and the bypass tray can be set so that the paper tray can be used with the specified paper size.

This is useful, for example, when the size of the paper that is loaded cannot be automatically detected (such as with postcards or paper in inch sizes).

The following procedure describes how to specify the 4 × 6  setting for the 1st tray.

- 1 In the Basic screen, touch [Paper].

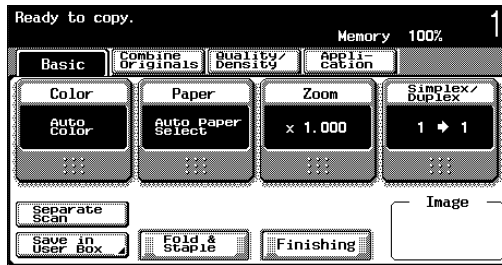

The Paper screen appears.

- 2 Touch the button for the 1st tray.
 - To set the paper size for the bypass tray, touch the button for the bypass tray.

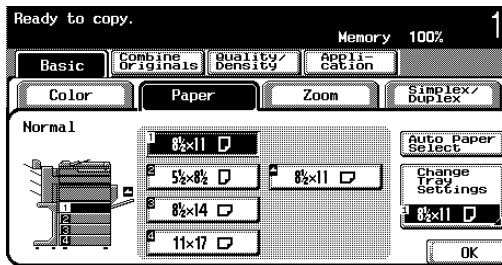

- 3 Touch [Change Tray Settings].

- 4 Touch [Standard Size].

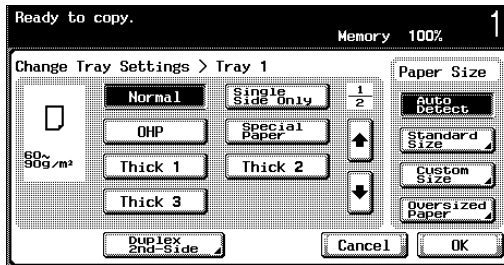

The Standard Size screen appears.

- 5 Touch [] twice, and then touch [4 × 6].

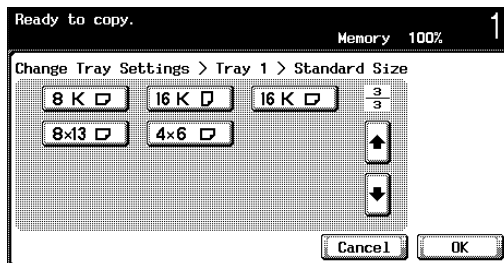

- Touch [] and [] until the button for the desired paper size is displayed.
- If “4 × 6 ” is selected, “Thick 2” is automatically selected. If paper other than postcards is loaded, change the paper type setting. For details on the paper type settings, refer to “To specify a setting for special paper” on page 7-21.

- 6 Touch [OK], and then touch [OK] in the next two screens that appear.

The Basic screen appears again.
The paper size for the 1st tray is set.



Reminder

If paper other than the specified paper size is loaded, a paper misfeed may occur since the paper size is not automatically detected.

To specify a non-standard paper size (Custom Size settings)

Non-standard-sized paper can be loaded into the 1st tray or the bypass tray. If non-standard-sized paper is loaded, it will be necessary to enter the paper size.

The following procedure describes how to specify the size of non-standard paper loaded into the 1st tray.

- 1 In the Basic screen, touch [Paper].

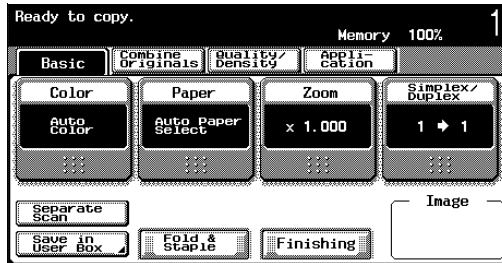

The Paper screen appears.

- 2 Touch the button for the 1st tray.
 - To set the paper size for the bypass tray, touch the button for the bypass tray.

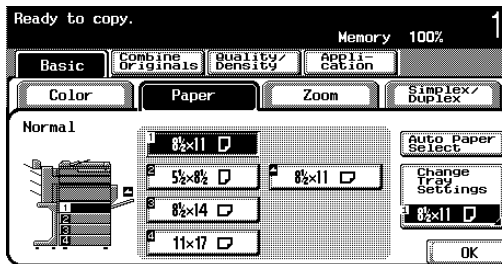

- 3 Touch [Change Tray Settings].

4 Touch [Custom Size].

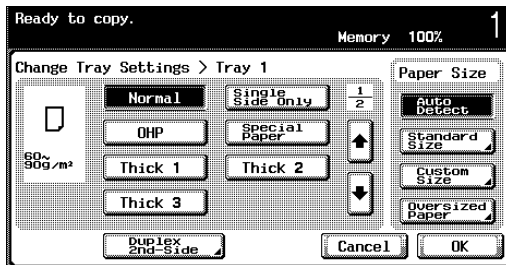

The Custom Size screen appears.

5 Type in the length (X) and width (Y) of the paper.

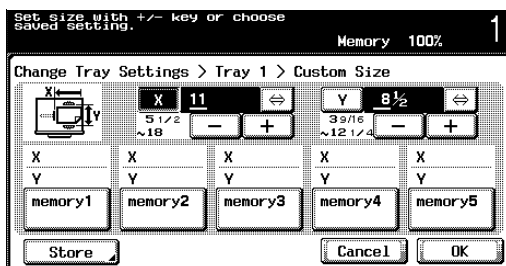

- Make sure that [X] is selected, touch [↔] to switch between the integer and the fraction, and then touch [-] and [+] to type in the length of side X. (5-1/2 in. to 18 in.)
- Make sure that [Y] is selected, touch [↔] to switch between the integer and the fraction, and then touch [-] and [+] to type in the length of side Y. (3-9/16 in. to 12-1/4 in.)
- If a decimal value is displayed in the screen, use the keypad to type in the length. For details on switching between decimal and fraction values, refer to “System setting” on page 12-17.
- If a decimal value is displayed in the screen and the specified value is outside the allowable range, the message “Input Error” appears. Type a value within the allowable range. If the value was incorrectly entered, press the [C] (clear) key to erase the value, and then specify the correct value.

? Can paper sizes be stored?

- Five non-standard paper sizes can be stored.
- To recall a stored paper size, touch the corresponding memory key.
- The names “memory1” through “memory5” can be changed. For details on changing the names, refer to “To store a non-standard paper size (Custom Size settings)” on page 7-15.

→ For details on storing paper sizes, refer to “To store a non-standard paper size (Custom Size settings)” on page 7-15.

- 6 Touch [OK], and then touch [OK] in the next two screens that appear. The Basic screen appears again.

To store a non-standard paper size (Custom Size settings)

Five non-standard paper sizes can be stored.

Storing paper sizes that are used often allows the paper size to be quickly selected, without having to re-enter the setting.

The following procedure describes how to store a non-standard paper size for the 1st tray.

- 1 In the Basic screen, touch [Paper].

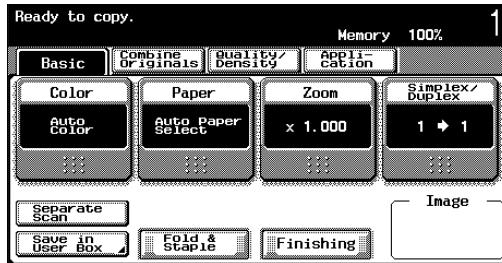

The Paper screen appears.

- 2 Touch the button for the 1st tray.
 - To specify a setting for special paper for the bypass tray, touch the button for the bypass tray.

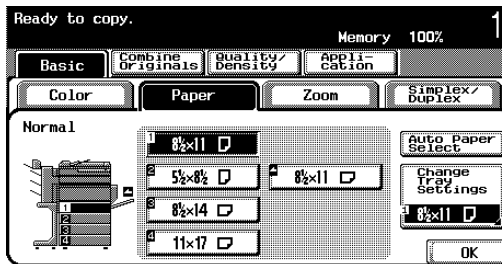

- 3 Touch [Change Tray Settings].

4 Touch [Custom Size].

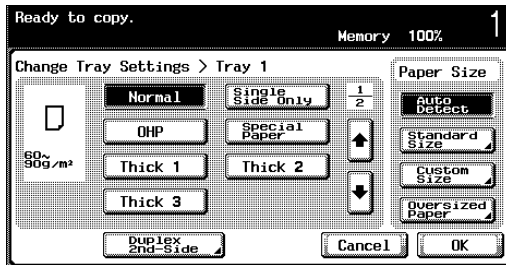

5 Specify the X and Y sides of the paper, and then touch [Store].

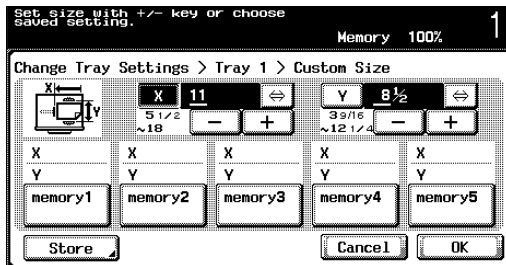

- Make sure that [X] is selected, touch [↔] to switch between the integer and the fraction, and then touch [-] and [+] to type in the length of side X. (5-1/2 in. to 18 in.)
- Make sure that [Y] is selected, touch [↔] to switch between the integer and the fraction, and then touch [-] and [+] to type in the length of side Y. (3-9/16 in. to 12-1/4 in.)
- Check the illustration in the screen for the sides that are considered X and Y.
- If a decimal value is displayed in the screen, use the keypad to type in the length. For details on switching between decimal and fraction values, refer to "System setting" on page 12-17.
- If a decimal value is displayed in the screen and the specified value is outside the allowable range, the message "Input Error" appears. Type a value within the allowable range. If the value was incorrectly entered, press the [C] (clear) key to erase the value, and then specify the correct value.

- 6 Touch the memory key where the paper size is to be stored.

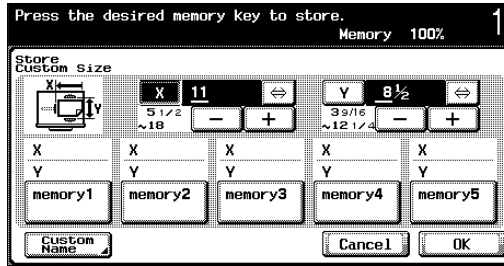

- To change the name of a memory key, touch [Custom Name], and then touch the key to be renamed.

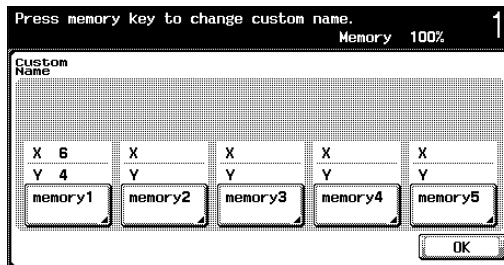

Using the keyboard that appears, type in the name of the key, touch [OK], and then touch [OK] again.

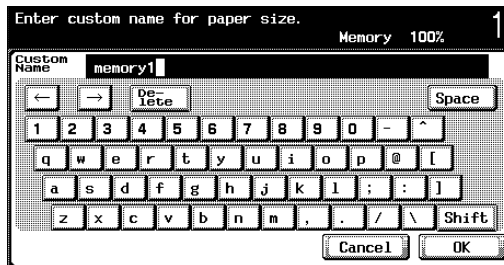

- For details on typing in text, refer to “Entering text” on page 13-2.

- 7 Touch [OK], and then touch [OK] in the next four screens that appear. The Basic screen appears again.

To specify a setting for oversized paper (Oversized Paper settings)

Oversized paper can be loaded into the 1st tray or the bypass tray.

Oversized paper is a size larger than the standard size and allows copies of standard-sized documents to be printed so that there is no loss at the edges. For example, if 11 × 17 Wide paper is used, an area up to 12-1/4 × 18 in. can be printed, allowing the entire area of an 11 × 17-size document to be printed.

If oversized paper is loaded, it will be necessary to enter the paper size.

The following procedure describes how to specify the setting for oversized paper loaded into the 1st tray.

- 1 In the Basic screen, touch [Paper].

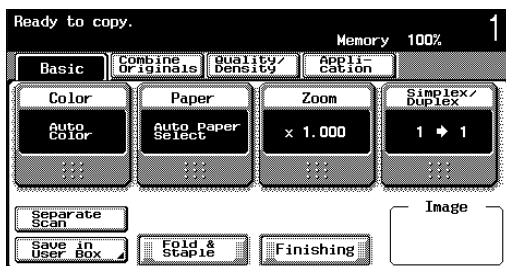

The Paper screen appears.

- 2 Touch the button for the 1st tray.
 - To set the paper size for the bypass tray, touch the button for the bypass tray.

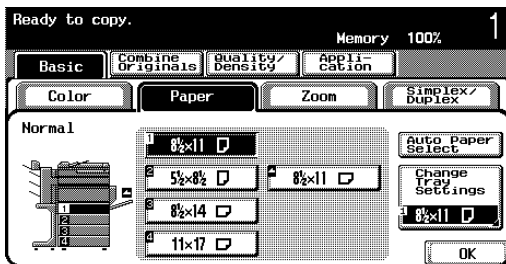

- 3 Touch [Change Tray Settings].

4 Touch [Oversized Paper].

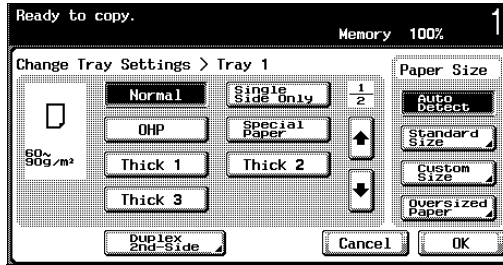

The Oversized Paper screen appears.

5 Select the size of the paper to be loaded.

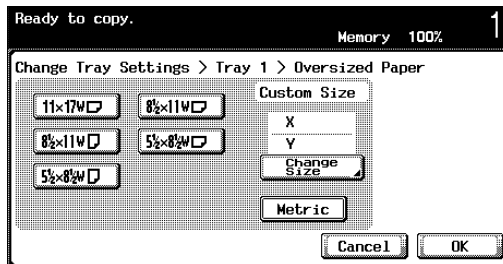

- To select a paper size in centimeters, touch [Metric]. The list of paper sizes in centimeters appears.



6 To change the size, touch [Change Size].

The Change Size screen for oversized paper appears.

7 Specify the X and Y sides of the paper, and then touch [OK].

- Touch [X] or [Y], touch [↔] to switch between the integer and the fraction, and then touch [-] and [+] to specify the size of the paper.
- If a decimal value is displayed in the screen, use the keypad to type in the setting. For details on switching between decimal and fraction values, refer to “System setting” on page 12-17.
- To specify a paper size of 12 × 18 , touch [12 × 18 ].

- If a decimal value is displayed in the screen and the specified value is outside the allowable range, the message "Input Error" appears. Type a value within the allowable range. If the value was incorrectly entered, press the [C] (clear) key to erase the value, and then specify the correct value.

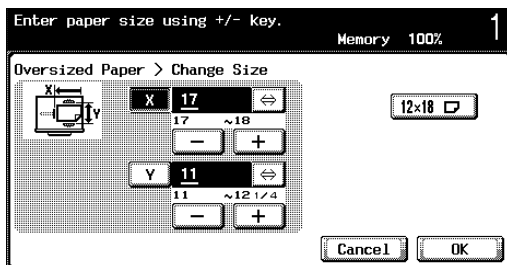

- 8 Touch [OK], and then touch [OK] in the next two screens that appear. The Basic screen appears again.



Note

The selected size button is programmed with the entered paper size, so that the paper size is available to be selected again without having to be typed in. In addition, the size can be changed.

To specify a setting for special paper

If a setting for special paper, such as overhead projector transparencies and other special paper, is selected for a paper tray, that tray is not selected automatically with the “Auto Paper Select” setting or the ATS feature. However, a paper tray set to “Single Side Only” is given priority when the “Auto Paper Select” setting is specified or when the paper trays are switched automatically.

The following procedure describes how to specify the setting for oversized paper loaded into the 1st tray.

- 1 In the Basic screen, touch [Paper].

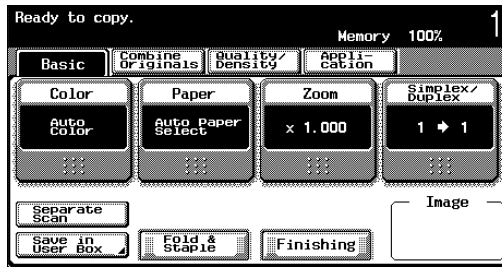

The Paper screen appears.

- 2 Touch the button for the 1st tray.
 - To set the paper size for the bypass tray, touch the button for the bypass tray.

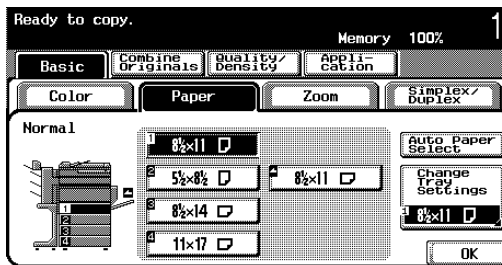

- 3 Touch [Change Tray Settings].

- 4 Specify the appropriate setting for the type of special paper loaded.
 - Touch the button for the desired special paper.

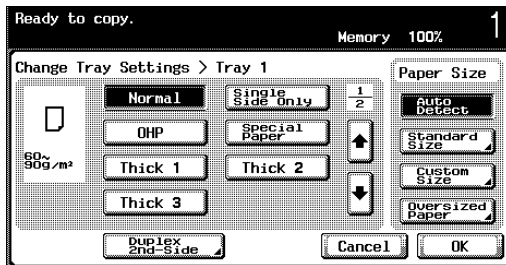

- ? What types of paper can be loaded in the paper tray?
- There are limits on the types of paper that can be loaded in a paper tray. For details on the type of paper that can be loaded, refer to “Specifications” on page 6-2, “Paper feed cabinet PC-103” on page 6-7.
- If postcards were loaded, select “Thick 2”.

- 5 Touch [OK], and then touch [OK] in the next screen that appears. The Basic screen appears again.



Reminder

If overhead projector transparencies or thick paper is loaded into the paper tray, be sure to select the corresponding paper type, otherwise a paper misfeed may occur.

To print double-sided copies manually

If the optional automatic duplex unit is not installed or if the document to be copied cannot be fed through the automatic duplex unit, touch [Duplex 2nd-Side] to print double-sided copies.

The following procedure describes how to specify the setting for paper already printed on one side and loaded into the 1st tray.

- 1 In the Basic screen, touch [Paper].

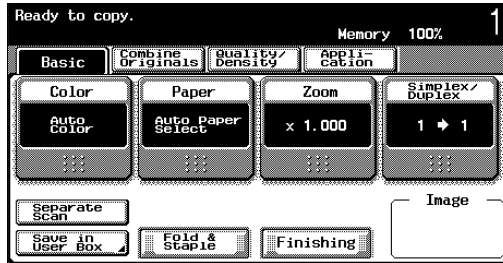

The Paper screen appears.

- 2 Touch the button for the 1st tray.
 - A paper tray set to “Duplex 2nd-Side” is not selected when the “Auto Paper Select” setting is selected.
 - To specify a setting for special paper for the bypass tray, touch the button for the bypass tray.

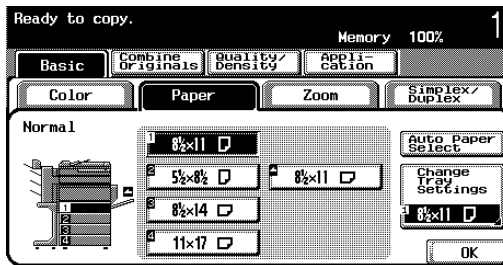

- 3 Touch [Change Tray Settings].

- 4 Touch [Duplex 2nd-Side].

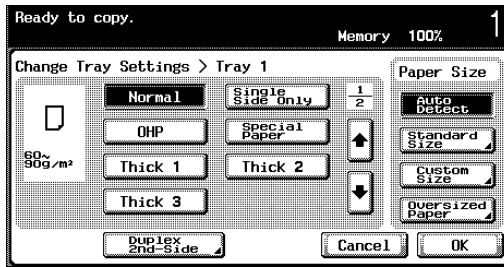

- 5 Select the setting for the type of used paper that is loaded.

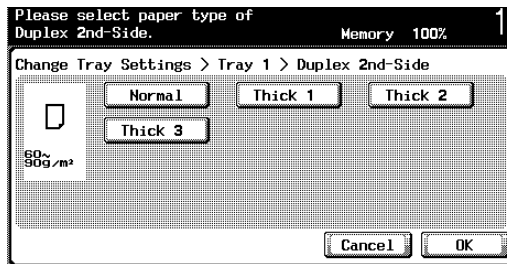

- 6 Touch [OK], and then touch [OK] in the next two screens that appear. The Basic screen appears again.

7.3 Original documents

When making copies, load the document into the ADF or position it on the original glass.

To copy documents that cannot be loaded into the ADF, position them on the original glass.





Documents that can be loaded into the ADF

There are three methods for using the ADF.

- Normal method
- For documents of mixed sizes
- For documents on thick paper

There are limits on the types of documents that can be loaded with each method.

Normal method

	Single-Sided Documents	Double-Sided Documents
Document paper type/ Weight	Plain Paper: 9-1/4 lb to 34 lb	Plain Paper: 13-1/4 lb to 29-1/4 lb
Document size	11 × 17  to 5-1/2 × 8-1/2  A3  to B6 	
Paper capacity	100 sheets (21-1/4 lb paper)	

For documents of mixed sizes

	Single-Sided Documents	Double-Sided Documents
Document paper type/ Weight	Plain Paper: 13-1/4 lb to 29-1/4 lb	
Document size	Refer to "Mixed originals paper sizes".	
Paper capacity	100 sheets (21-1/4 lb paper)	

Mixed originals paper sizes

The following chart shows the possible combinations of standard-sized paper that can be used with the “Mixed Original” setting.

Maximum Document Width ^{*1} → ↓ Document Size ^{*2}	11 × 17 ☐	8-1/2 × 11 ☐	8-1/2 × 14 ☐	8-1/2 × 11 ☐	5-1/2 × 8-1/2 ☐	5-1/2 × 8-1/2 ☐
11 × 17 ☐	○	○	—	—	—	—
8-1/2 × 11 ☐	○	○	—	—	—	—
8-1/2 × 14 ☐	○	○	○	○	○	—
8-1/2 × 11 ☐	○	○	○	○	○	—
5-1/2 × 8-1/2 ☐	—	—	○	○	○	—
5-1/2 × 8-1/2 ☐	—	—	—	—	—	○

○: Possible

—: Not possible

**Detail**

^{*1}Indicates the width of the widest document size of the mixed originals (width of the adjustable document guides of the ADF)

^{*2}Indicates document sizes that can be specified together with the maximum document width

For documents on thick paper

	Single-Sided Documents
Document paper type/Weight	Thick paper: 34-1/4 to 55-3/4
Document size	11 × 17 ☐ to 5-1/2 × 8-1/2 ☐/☐ A3 ☐ to B6 ☐
Paper capacity	38 sheets (55-3/4 paper)

Precautions for loading documents into the ADF

The following types of documents should not be loaded into the ADF, otherwise paper misfeeds or damage to the document may occur.

- Wrinkled, folded, curled, or torn documents
- Highly translucent or transparent documents, such as overhead transparencies or diazo photosensitive paper
- Coated documents such as carbon-backed paper
- Documents printed on paper thicker than 56-1/4 lb
- Documents printed on paper thicker than 29-1/2 lb during double-sided copying
- Documents that are bound, for example, with staples or paper clips
- Documents that are bound in a book or booklet
- Documents that are bound together with glue
- Document pages that have been cut or contain cutouts
- Label sheets
- Offset printing masters
- Documents with binder holes
- Documents that have just been printed with this machine







Reminder

Before loading folded documents, such as those folded in half or in three, into the ADF, be sure to flatten the pages.

Documents that can be placed on the original glass

To copy documents that cannot be loaded into the ADF, position them on the original glass.

	Original Glass Documents
Document type	Sheets, books (spreads), three-dimensional objects
Document size	11 × 17  to 5-1/2 × 8-1/2  A3  to A5 
Maximum weight	4-1/2 lb

Precautions for positioning documents on the original glass

Observe the following precautions when placing the document on the original glass.

- The size of documents printed on paper in metric sizes (such as A3, B4, A4) cannot be automatically detected. The setting must be specified by the technical representative. For details, contact the technical representative.
- If a document of non-standard paper size is loaded, the “Auto Paper Select” and “Auto Zoom” settings cannot be used since the document size cannot be detected automatically. If a document of non-standard paper size is loaded, select the size of the paper to be copied.
- If highly translucent or transparent documents, such as overhead transparencies or diazo photosensitive paper, are loaded, the document size cannot be detected automatically. Place a blank sheet of paper of the same size over the document.
- Do not place objects exceeding 4-1/2 lb on the original glass, otherwise the original glass may be damaged.
- If a book is placed on the original glass, do not press it down extremely hard, otherwise the original glass may be damaged.



Application functions

8 Application functions

8.1 Inserting paper between overhead projector transparencies (“OHP Interleave” function)

In order to prevent copies printed onto overhead projector transparencies from sticking together as a result of the heat that is produced during copying, paper (interleaf) can be inserted between the transparencies

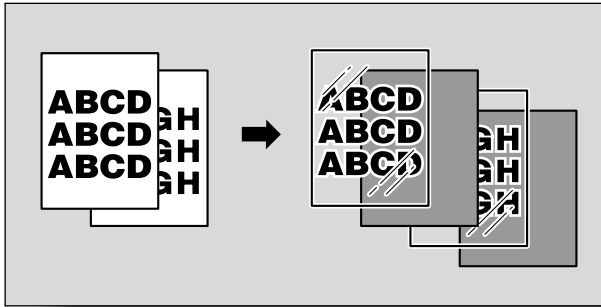

Detail

For details on loading overhead projector transparencies, refer to “Paper types and paper capacities” on page 7-4, “Loading paper into the bypass tray” on page 2-58.

To copy using the “OHP Interleave” function

- ✓ The Finishing setting cannot be changed.
 - ✓ The number of copies is set to “1” and cannot be changed.
- 1 Position the document to be copied.
 - For details on positioning the document, refer to “Feeding the document” on page 3-7.
 - 2 Load overhead projector transparencies into the bypass tray or the 1st tray. Load the interleaf paper into the desired paper tray.
 - Use interleaf paper with the same size as the overhead projector transparencies, and load them in the  orientation.
 - 3 Touch [OHP], and then touch [OK].
 - If the overhead projector transparencies are loaded into the 1st tray, touch [Paper], select the 1st tray, and then touch [Change Tray Settings].

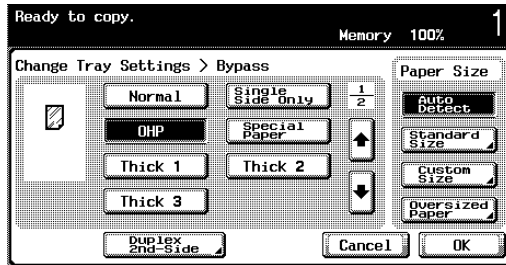

The Paper screen appears.

- 4 Touch [Application], and then touch [Sheet/Cover/Chapter Insert].
 - To cancel all settings for the Application functions, touch [Reset].

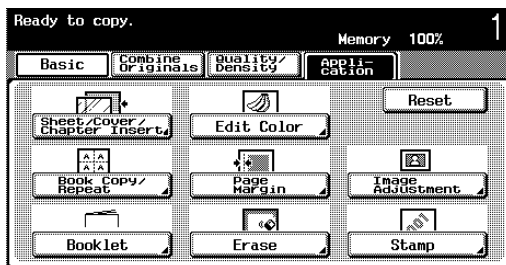

The Sheet/Cover/Chapter Insert screen appears.

- 5 Touch [OHP Interleave].

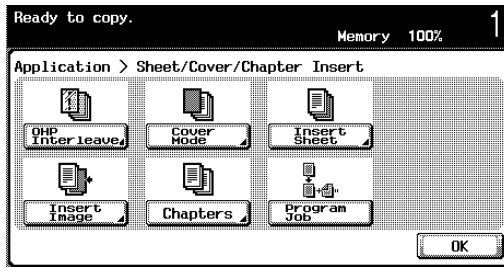

The OHP Interleave screen appears.

- 6 Select the paper tray loaded with the interleaf paper.
- To cancel changes to the settings, touch [Cancel].
 - To cancel the "OHP Interleave" function, touch [OFF].

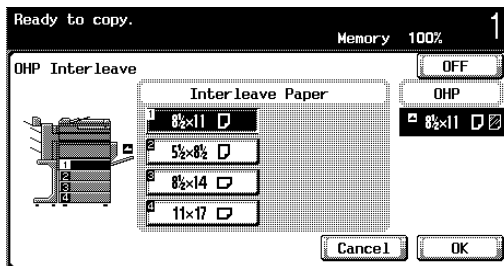

- 7 Touch [OK].
- 8 If necessary, specify any other copy settings.
- 9 Press the [Start] key.

8.2 Adding cover pages (“Cover Mode” function)

Copies can be made using paper different from the cover pages and main body of the document (excluding the cover pages) and cover pages can be added using paper different from the copy.

The following types of cover pages and front and back cover page settings are available.

Setting	Description
Front (Copy)	The first page of the document is copied onto paper for the front cover sheet. With double-sided copying, the second page of the document is copied onto the back of the front cover sheet.
Front (Blank)	Paper for the front cover sheet is added as the first page of the copy. The same operation is performed with double-sided copying.
Back (Copy)	The last page of the document is copied onto paper for the back cover sheet. With double-sided copying, a double-sided copy of the last two pages of the document is printed on paper for the back cover sheet if the document contains an even number of pages.
Back (Blank)	Paper for the back cover sheet is added after the last page of the copy. The same operation is performed with double-sided copying.

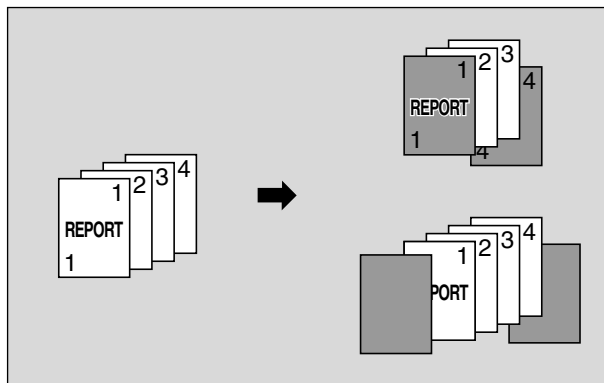

To copy using the “Cover Mode” function

- 1 Position the document to be copied.
 - For details on positioning the document, refer to “Feeding the document” on page 3-7.
 - For a document that exceeds 100 pages, refer to “Scanning the document in separate batches (“Separate Scan” setting)” on page 3-11.
- 2 Load the paper for the cover pages and the paper for the main body of the document into separate paper trays.
 - Use paper with the same size for the cover pages and for the main body of the document, and load them in the same orientation.
- 3 Touch [Application], and then touch [Sheet/Cover/Chapter Insert].
 - For details on loading paper when using thick paper for the cover page, refer to “Paper types and paper capacities” on page 7-4, “Loading paper into the bypass tray” on page 2-58.
 - To cancel all settings for the Application functions, touch [Reset].

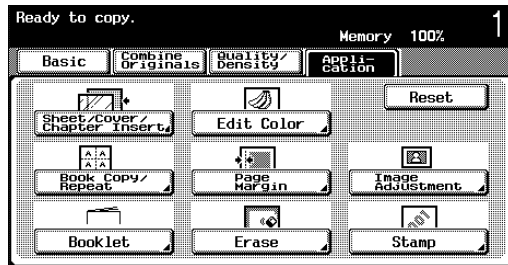

The Sheet/Cover/Chapter Insert screen appears.

- 4 Touch [Cover Mode].

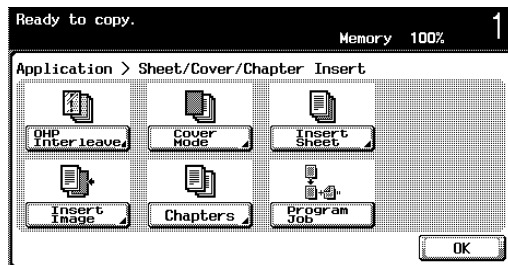

The Cover Mode screen appears.

- 5 Select the desired cover sheet format.
 - The default setting for the paper tray loaded with cover pages can be specified from the Utility mode. For details, refer to “Copier setting” on page 12-22.
 - To cancel changes to the copy settings, touch [Cancel].
 - To cancel the “Cover Mode” function, touch [OFF].

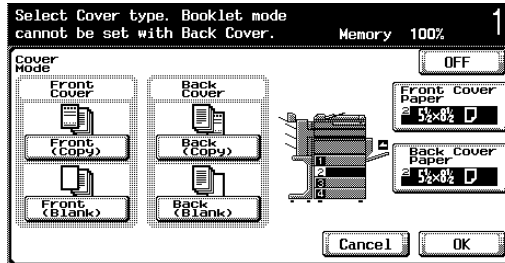

- 6 Depending on the desired setting, touch [Front Cover Paper] or [Back Cover Paper].

The corresponding Cover Paper screen appears.

- 7 Select the paper tray loaded with the paper for the cover pages.

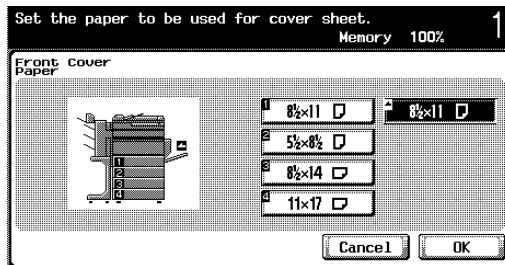

- 8 Touch [OK], and then touch [OK] in the next screen that appears.
- 9 If necessary, specify any other copy settings.
- 10 Using the keypad, type in the desired number of copies.
- 11 Press the [Start] key.

8.3 Inserting different paper into copies (“Insert Sheet” function)

Different paper (such as colored paper) can be inserted for specified pages in the copies.

There are settings (“Copy” and “Blank”) for selecting whether or not the inserted pages are printed. When the settings are combined with single-sided copying or double-sided copying, the copies are printed as shown below.

If “Copy” is set, the document is copied as shown below when the specified paper is inserted for the specified page.

When page 6 is specified

Finishing	Description
Single-sided copies	The specified paper is inserted for the 6th page of the copy, and the 6th page of the document is copied onto it.
Double-sided copies	The back side of the 3rd page of the copy is left blank, the specified paper is inserted for the 4th page of the copy, and a double-sided copy of the 6th and 7th pages of the document are printed onto it.

If “Blank” was set, the specified paper is inserted after the specified page.

When page 5 is specified

Finishing	Description
Single-sided copies	The specified paper is inserted as the 6th page of the copy.
Double-sided copies	The back side of the 3rd page of the copy is left blank, and the specified paper is inserted for the 4th page of the copy.



Detail

The specified paper can be inserted at a maximum of 15 locations within a document of up to 999 pages.

In double-sided documents, one double-sided page is considered to be two pages (one for the front and one for the back).

Double-sided copying is possible only if automatic duplex unit is installed.

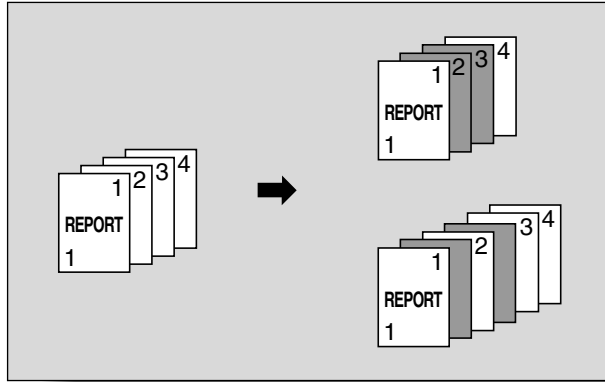

To copy using the “Insert Sheet” function

- 1** Position the document to be copied.
 - For details on positioning the document, refer to “Feeding the document” on page 3-7.
 - For a document that exceeds 100 pages, refer to “Scanning the document in separate batches (“Separate Scan” setting)” on page 3-11.
- 2** Load the paper to be inserted and the paper for the main body of the copy into separate paper trays.
 - Make sure that the paper loaded for the insertion and for the copy have the same size and orientation.
- 3** Touch [Application], and then touch [Sheet/Cover/Chapter Insert].
 - For details on loading paper when using thick paper for the insertions, refer to “Paper types and paper capacities” on page 7-4 and “Loading paper into the bypass tray” on page 2-58.

- To cancel all settings for the Application functions, touch [Reset].

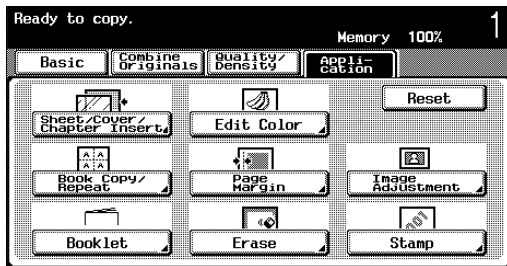

The Sheet/Cover/Chapter Insert screen appears.

- 4 Touch [Insert Sheet].

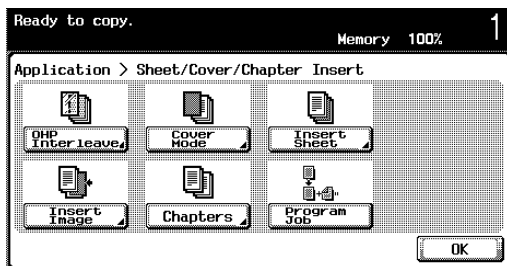

The Insert Sheet screen appears.

- 5 Using the keypad, specify the pages where the paper is to be inserted.
 - When [Select] is touched, the entered page is specified.
 - After the page number is specified, the page numbers are arranged in order, starting with the lowest number.
 - To remove a page number that has been specified, touch [Edit], touch the button for the page to be removed, and then press the [C] (clear) key.
 - If the same page number is entered twice, the same page number is specified, and there is no change to the print result.
 - If the entered page number is greater than the number of pages in the document, paper is not inserted.

- 6 Touch [Insert Paper].
 - To cancel changes to the settings, touch [Cancel].
 - To cancel the “Insert Sheet” function, touch [OFF].

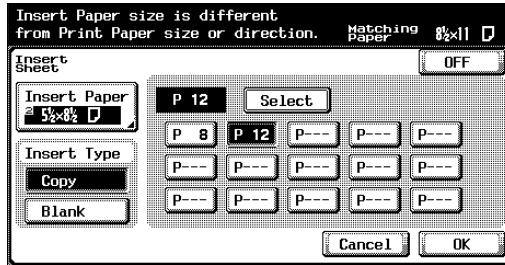

The Insert Paper screen appears.

- 7 Select the paper tray loaded with the paper for the insertion sheets, and then touch [OK].

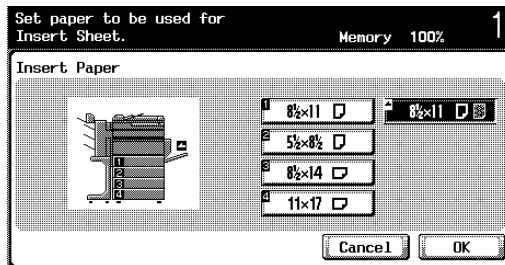

- 8 Touch [Copy] or [Blank] under “Insert Type”.
 - If “Copy” is set, the document is copied with the specified paper inserted for the specified page.
 - If “Blank” is set, the specified paper is inserted after the specified page.
- 9 Touch [OK].
- 10 If necessary, specify any other copy settings.
- 11 Using the keypad, type in the desired number of copies.
- 12 Press the [Start] key.

8.4 Inserting copies of a different document for a specified page (“Insert Image” function)

A multi-page document later scanned from the original glass can be inserted at the specified location in a document first scanned with the ADF. The inserted document is added after the specified pages.



Detail

A separate document can be inserted at a maximum of 15 locations within a document of up to 999 pages.

In double-sided documents, one double-sided page is considered to be two pages (one for the front and one for the back).

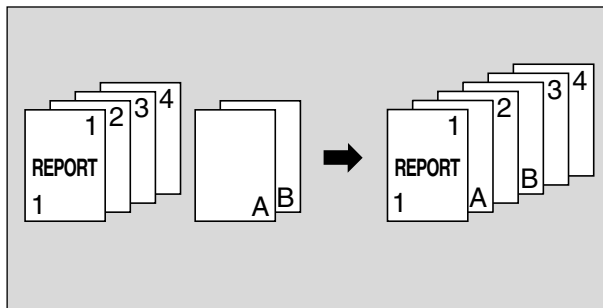

To copy using the “Insert Image” function

- 1 Load the document into the ADF.
 - For details on positioning the document, refer to “Feeding the document” on page 3-7.
 - For a document that exceeds 100 pages, refer to “Scanning the document in separate batches (“Separate Scan” setting)” on page 3-11.

- 2 Touch [Application], and then touch [Sheet/Cover/Chapter Insert].
 - To cancel all settings for the Application functions, touch [Reset].

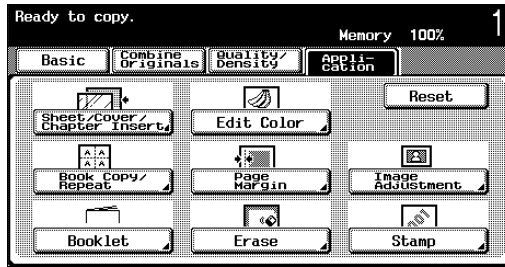

The Sheet/Cover/Chapter Insert screen appears.

- 3 Touch [Insert Image].

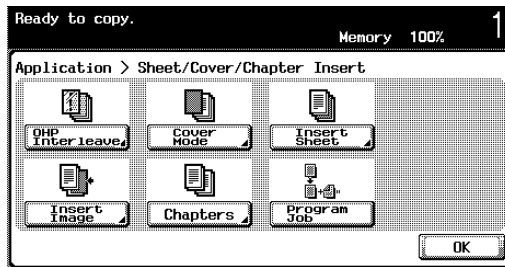

The Insert Image screen appears.

- 4 Using the keypad, specify the pages where the image is to be inserted.
 - To cancel changes to the settings, touch [Cancel].
 - To cancel the "Insert Image" function, touch [OFF].
 - The inserted document is added after the specified page.

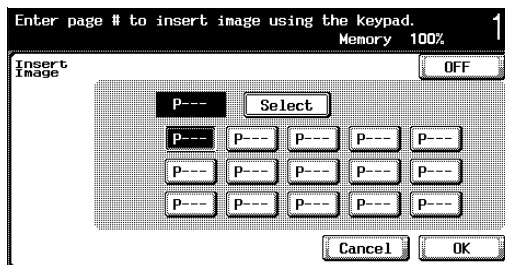

- When [Select] is touched, the entered page is specified.
- After the page number is specified, the page numbers are arranged in order, starting with the lowest number.

- To remove a page number that has been specified, touch [Edit], touch the button for the page to be removed, and then press the [C] (clear) key.
- If the total number of pages in the document to be inserted is greater than the number of pages that are specified, the remaining pages of the insertion document are added at the end of the document.
- If the total number of pages in the document to be inserted is less than the number of pages that are specified, nothing is inserted at the specified locations greater than the total number of pages in the document.
- If the same page number is specified twice, two insertion documents are added at the specified location.
- If the specified page number is greater than the total number of pages in the main document, the corresponding insertion document page is added at the end of the document copy.

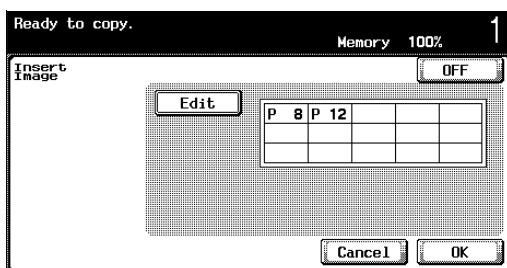

- 5 Touch [OK].
- 6 If necessary, specify any other copy settings.
- 7 Using the keypad, type in the desired number of copies.
- 8 Press the [Start] key.
Scanning begins.



- 9 Place the document to be inserted on the original glass.
 - For details on positioning the document, refer to “Feeding the document” on page 3-7.
- 10 Press the [Start] key.

Scanning begins.
- 11 Touch [Finish].

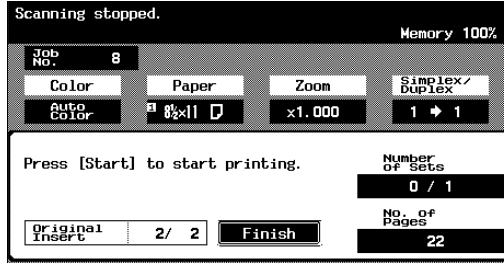

- To insert a multi-page document, repeat steps 9 and 10 until all pages of the insertion document are scanned in the order that they are to be inserted.

- 12 Press the [Start] key.

8.5 Specifying pages to be printed on the front side (“Chapters” function)

When making double-sided copies, the pages specified as the first page of a chapter can be printed on the front side of the paper. If the document was arranged so that the specified page would be printed on the back side of a page, the page is left blank and the specified page is printed on the front side of the next page. In addition, the specified page can be printed on different paper.



Detail

A maximum of 15 pages can be specified to be printed on the front side of the paper within a document of up to 999 pages.

In double-sided documents, one double-sided page is considered to be two pages (one for the front and one for the back).

This function is available only when optional automatic duplex unit is installed.

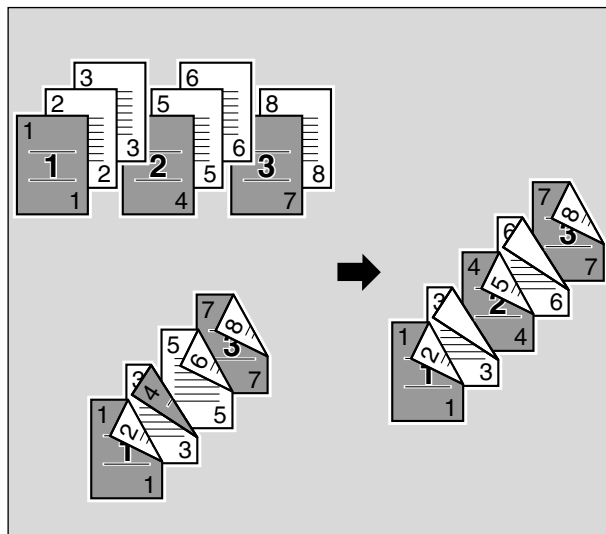

To copy using the “Chapters” function

Make sure that the paper loaded for the first page of the chapter and for the copy have the same size and orientation.

- 1 Position the document to be copied.
 - For details on positioning the document, refer to “Feeding the document” on page 3-7.
 - For a document that exceeds 100 pages, refer to “Scanning the document in separate batches (“Separate Scan” setting)” on page 3-11.
- 2 Touch [Application], and then touch [Sheet/Cover/Chapter Insert].
 - To cancel all settings for the Application functions, touch [Reset].

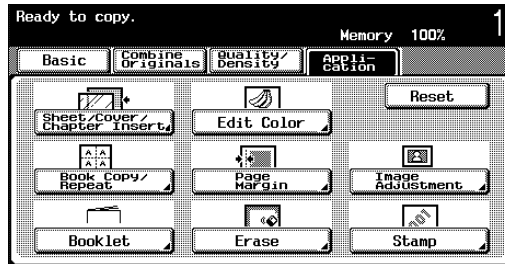

The Sheet/Cover/Chapter Insert screen appears.

- 3 Touch [Chapters].

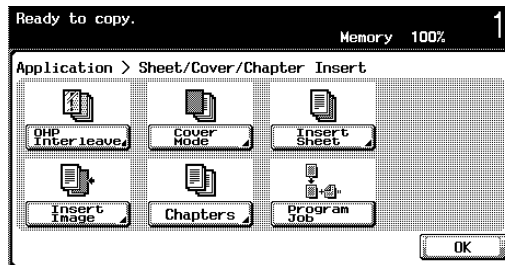

The Chapters (editing) screen appears.

- 4 Using the keypad, specify the first page of the chapters.
 - When [Select] is touched, the entered page is specified.
 - After the page number is specified, the page numbers are arranged in order, starting with the lowest number.

- To remove a page number that has been specified, touch [Edit], touch the button for the page to be removed, and then press the [C] (clear) key.
- Set “Simplex/Duplex” to “1 → 2”.
- If the same page number is entered twice, the same page number is specified, and there is no change to the print result.
- If the specified page number is greater than the number of pages in the document, that page number is ignored.

5 Touch [Copy Insert] or [None] under “Chapter Paper”.

- If “None” is selected, all pages of the copy are printed on the same paper.
- To cancel changes to the settings, touch [Cancel].
- To cancel the “Chapters” function, touch [OFF].

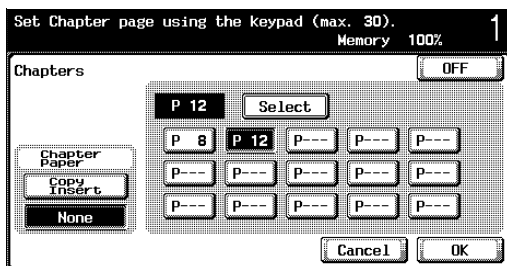

- If “Copy Insert” is selected, [Chapter Paper] appears. Touch [Chapter Paper], select the paper to be used for the first page of the chapter, and then touch [OK].

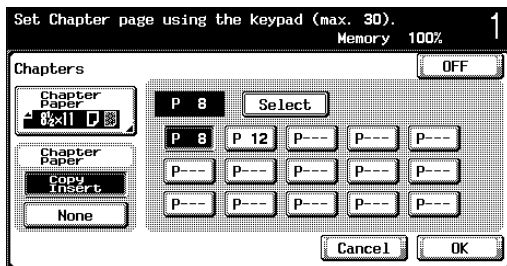

6 Touch [OK].

7 If necessary, specify any other copy settings.

8 Using the keypad, type in the desired number of copies.

9 Press the [Start] key.

8.6 Scanning documents with different settings and printing copies all together (“Program Job” function)

Loaded document pages can be scanned with different settings and their copies can be printed together. Different Zoom or Paper settings can be specified for a part of the document or Finishing settings or the “Set Numbering” function can be set after the entire document is scanned, and then all copies can be printed together.

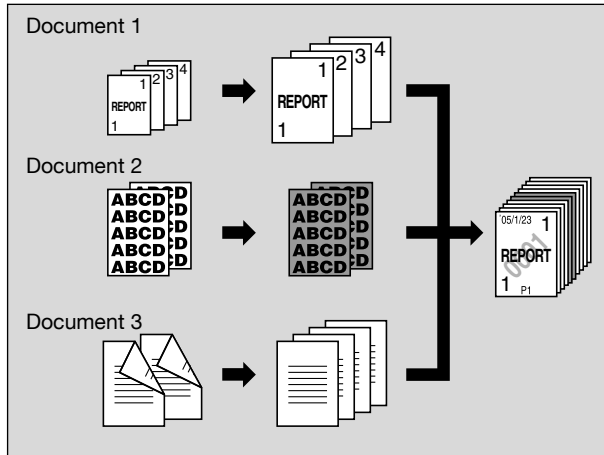

Note

Ten document batches can be set.

To copy using the “Program Job” function

- 1 Position the document to be copied.
 - For details on positioning the document, refer to “Feeding the document” on page 3-7.
 - When saving scanned data in a box, some scanned data may be lost if more than 9,000 pages are saved in the box.
- 2 Touch [Application], and then touch [Sheet/Cover/Chapter Insert].
 - To cancel all settings for the Application functions, touch [Reset].

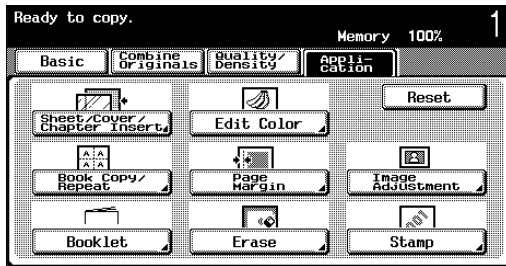

The Sheet/Cover/Chapter Insert screen appears.

- 3 Touch [Program Job], and then touch [OK].

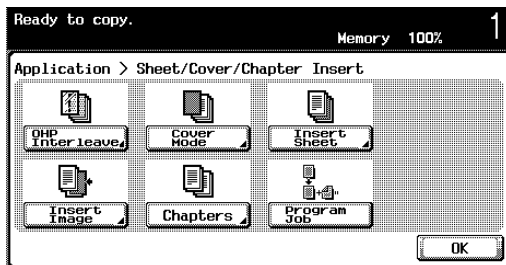

- 4 Select the desired copy settings, and then press the [Start] key.
 - To print a single copy to be checked, touch [Proof Copy] key. Scanning begins.

- 5 Select [Fix], and then touch [OK].

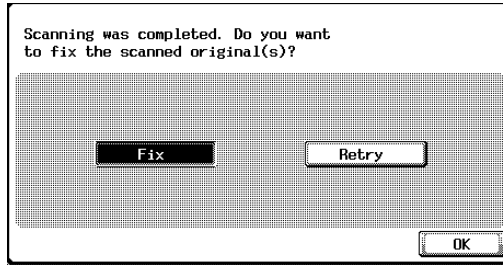

- To change the copy settings, select [Retry], and then touch [Change Setting].
- If the document is placed on the original glass, touch [Finish] in the screen that appears, requesting confirmation that scanning of the document is finished.

- 6 Position the next document batch, and then touch [Change Setting].

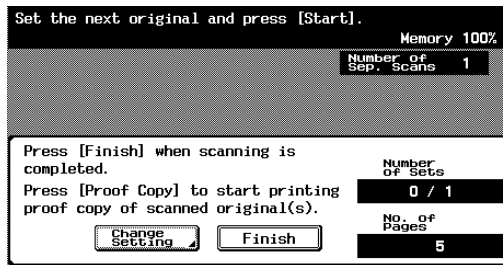

- 7 Select the desired copy settings, and then press the [Start] key.

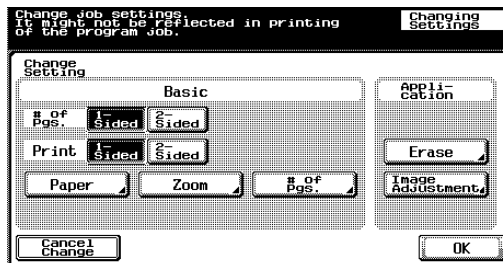

- To print a single copy to be checked, touch [Proof Copy] key.

- Repeat steps 6 and 7 until all document batches have been scanned. The amount of memory available can be checked beside “Memory” in the upper-right corner of the screen. In addition, the number of document batches can be checked beside “Number of Sep. Scans”.
- If not enough space is available in the memory, a message appears. Select whether to delete the last part of the data and scan it again, delete the last part of the data and print, or delete all of the document data.
- To cancel changes to the settings, touch [Cancel Change].

Scanning begins. After scanning is finished, select [Fix], and then touch [OK].

? Is there more information about the settings?

→ Refer to the appropriate section.

8 After all document pages have been scanned, touch [Finish].

A message appears, requesting confirmation that scanning is finished.

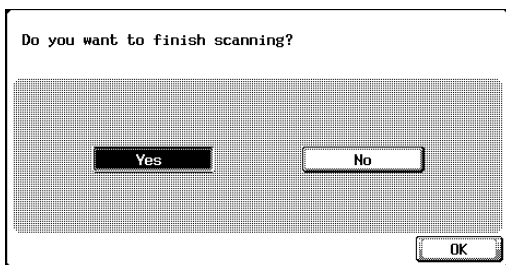

9 Select [Yes], and then touch [OK].

To change the copy settings, select [No], and then touch [Change Setting].

10 Specify any other desired copy settings.

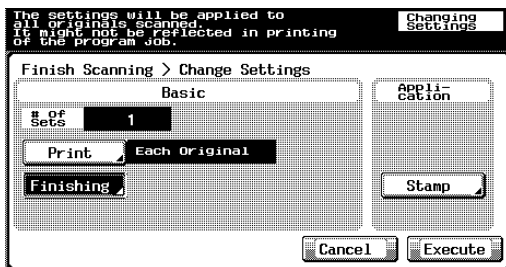

- Touch [Print], and then specify the printing method for the entire scanned document.

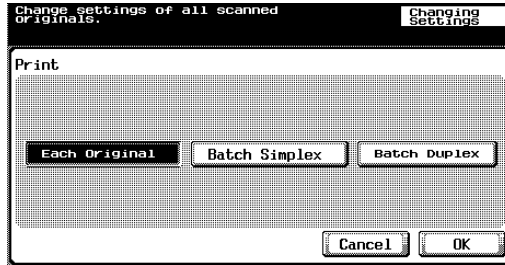

- ? Is there more information about the settings?
→ Refer to the appropriate section.

- 11 Using the keypad, type in the desired number of copies.
- 12 Touch [Execute] or press the [Start] key.
 - If [Cancel] is touched, a message appears, requesting confirmation to delete the data. To stop printing, select [Yes], and then touch [OK].

8.7 Producing separate copies of each page in a page spread (“Book Copy” function)

An open book or catalog can be copied with the left and right pages on separate sheets of paper.

The following copy methods are available, and there are settings for adding just a front cover or both front and back covers.

Setting	Description
Book Spread	Copies of the left and right pages of the page spread are printed on the same page without being separated.
Separation	Separate copies of each page in the page spreads are printed in the document page order. The document is scanned to fit the size of paper that will be used.
Front Cover	The front cover and separate copies of each page in the page spreads are printed in the document page order.
Front and Back Cover	The front cover, separate copies of each page in the page spreads and the back cover are printed in the document page order.

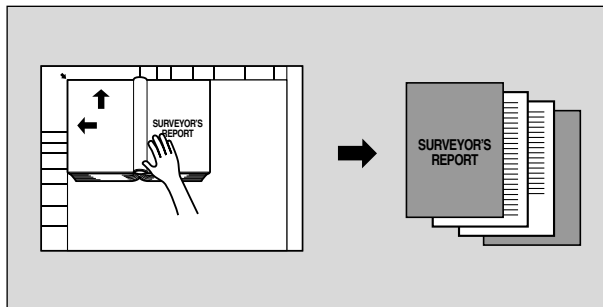

To copy using the “Book Copy” function

✓ Place the document on the original glass.

- 1 Place the pages on the original glass, starting with the first page.
 - For details on positioning the document, refer to “Feeding the document” on page 3-7.
 - To add copies of the covers, load them first.

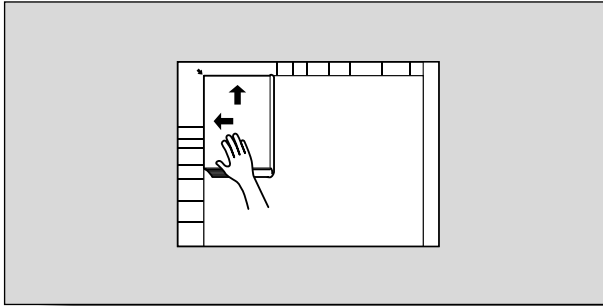

? How are the front and back covers copied?

→ Scan the front cover, then the back cover, and then scan the remainder of the document.

- 2 Load the paper to be used into the desired paper tray.
- 3 Touch [Application], and then touch [Book Copy/Repeat].
 - To cancel all settings for the Application functions, touch [Reset].

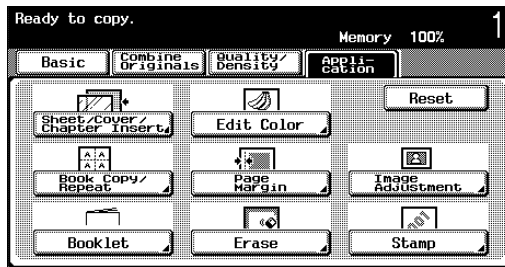

The Book Copy/Repeat screen appears.

4 Touch [Book Copy].

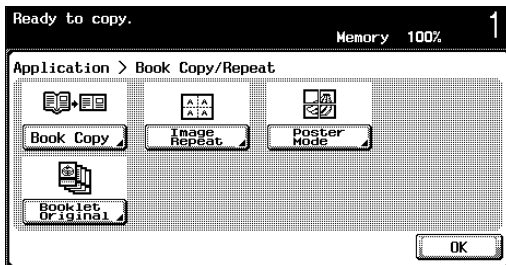

The Book Scanning screen appears.

[Booklet Original] appears if the saddle stitcher is installed on optional finisher FS-514 or optional finisher FS-603 is installed.

5 Touch the button for the desired setting.

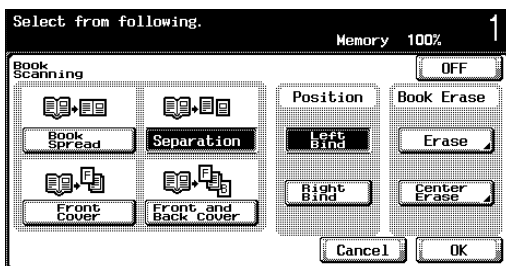

- Touch [↔] to switch between the integer and the fraction, touch [-] and [+] to specify the width to be erased, and then touch [OK].
- If a decimal value is displayed in the screen, use the keypad to type in the setting. For details on switching between decimal and fraction values, refer to “System setting” on page 12-17.
- If a decimal value is displayed in the screen and the specified value is outside the allowable range, the message “Input Error” appears. Type a value within the allowable range. If the value was incorrectly entered, press the [C] (clear) key to erase the value, and then specify the correct value.
- If [Separation], [Front Cover] or [Front and Back Cover] is selected, “Position” appears. Select the binding position of the document.
- If necessary, touch [Erase] or [Center Erase] under “Book Erase”. Select the desired area to be erased, touch [-] and [+] to specify the width to be erased, and then touch [OK].
- If a Book Erase function is specified, touch [Image Adjustment] in the Application screen, touch [Standard Size], and then specify the size of the document.
- To cancel changes to the settings, touch [Cancel].

- To cancel the “Book Copy” function, touch [OFF].

Center Erase screen

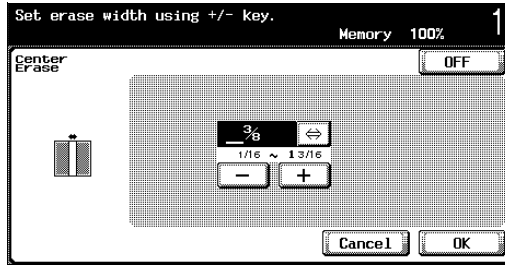

? What do the Book Erase functions do?

→ The shadow of the book binding and the shadow of the book edges can be erased from the copies. The “Erase” and “Center Erase” functions can be used together.

? How are settings specified for the “Erase” function?

→ Refer to “Erasing specified areas of copies (“Erase” function)” on page 8-61. In addition, if the “Erase” function in the Application screen is specified, [Erase] under “Book Erase” will be selected.

6 Touch [OK], and then touch [OK] in the next screen that appears.

7 In the Basic screen, touch [Paper], and then select the paper tray loaded with the paper.

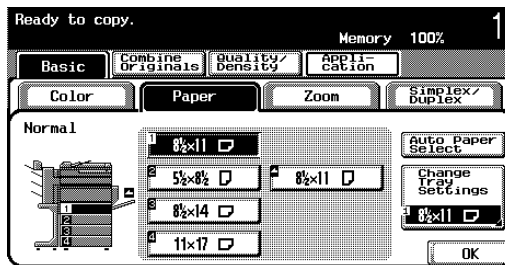

8 If necessary, specify any other copy settings.

9 Using the keypad, type in the desired number of copies.

10 Press the [Start] key.

- For details on scanning the document, refer to “Scanning a multi-page document from the original glass” on page 3-15. Scanning begins.

- ? How are documents with multiple pages scanned?
 → Position the next page and repeat step 10 until all pages of the document are scanned.

11 After all document pages have been scanned, touch [Finish].

- If "Front and Back Cover" was selected, the back cover is scanned after the front cover, and then all page spreads are scanned in order.

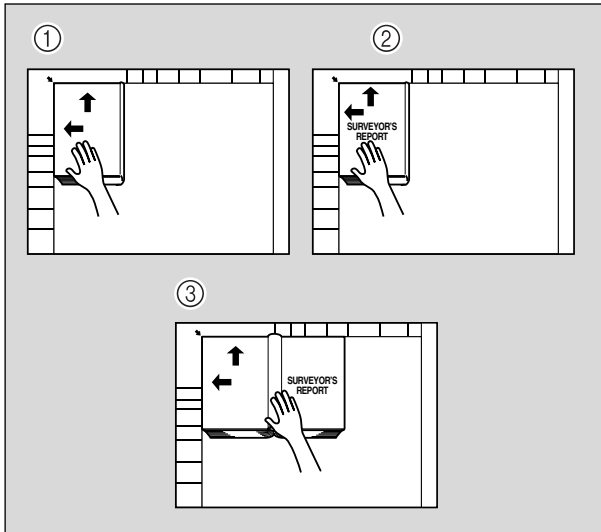

- If "Front Cover" was selected, all page spreads are scanned in order after the front cover.

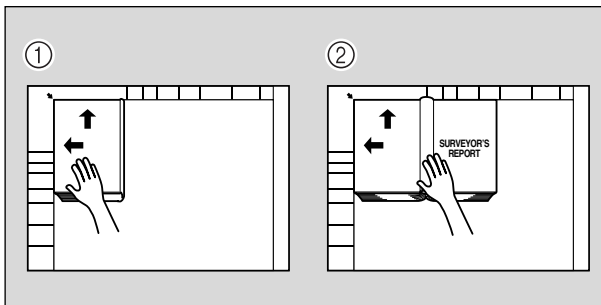

12 Press the [Start] key.

8.8 Copying pamphlets (“Booklet Original” function)

A pamphlet with its staples removed can be copied and bound with staples at the center to create copies of the original pamphlet.

Setting	Description
Center Erase ON	The pages are copied with a 1/2 in. margin at the center of the document (area bound with staples).
Center Erase OFF	Copies are made of the entire page, including the center of the document (area bound with staples).

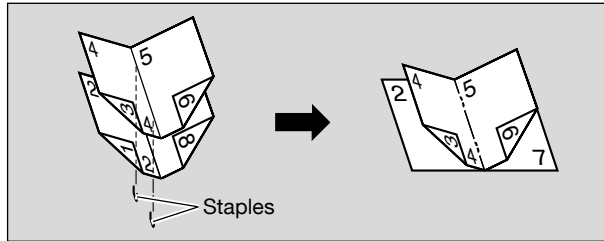

Detail

For details on stapling, refer to “Specifying center binding” on page 3-80.

The number of sheets that can be stapled together is no more than 15 and differs depending on the paper type. For details, refer to “Specifying center binding” on page 3-80.

To copy using the “Booklet Original” function

- ✓ This function is available if the saddle stitcher is installed on optional finisher FS-514 or optional finisher FS-603 is installed.

1 Position the document to be copied.

- Load a booklet with the staples removed.
- For details on positioning the document, refer to “Feeding the document” on page 3-7.
- When using the original glass, position the pages in order, starting with the side that includes the first page, then the side that includes the second page, then the side that includes the third page.

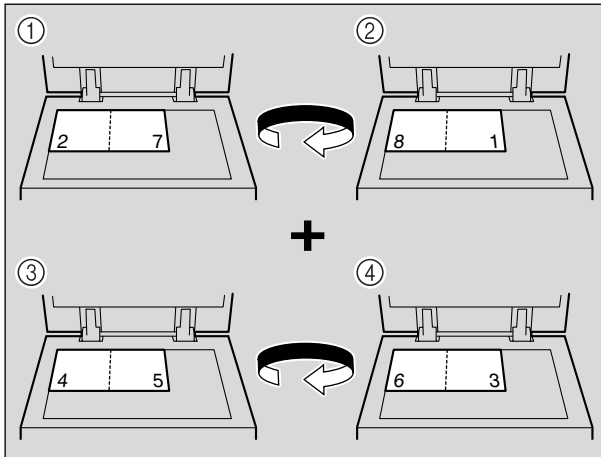

- When using the ADF, load the pages with the side that includes the first page on top.

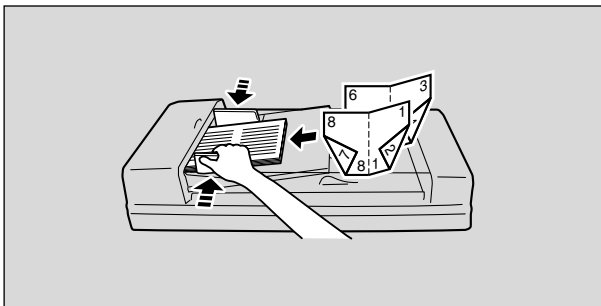

- 2 Touch [Application], and then touch [Book Copy/Repeat].
 - To cancel all settings for the Application functions, touch [Reset].

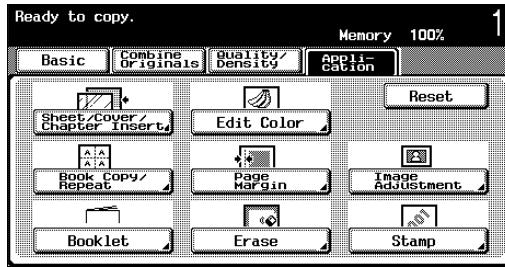

The Book Copy/Repeat screen appears.

- 3 Touch [Booklet Original].

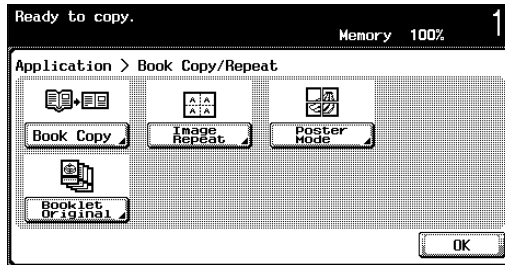

The Booklet Original screen appears.

- 4 Touch either [Center Erase ON] or [Center Erase OFF].

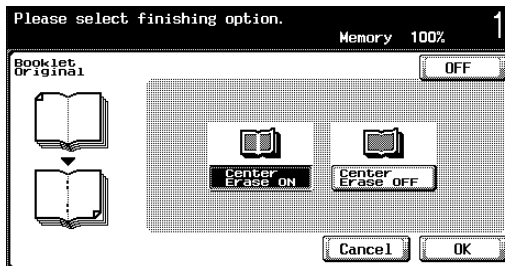

- To cancel changes to the settings, touch [Cancel].
- To cancel the “Booklet Original” function, touch [OFF].

- 5 Touch [OK].
- 6 If necessary, specify any other copy settings.

- 7 Using the keypad, type in the desired number of copies.
- 8 Press the [Start] key.
 - If the document is placed on the original glass, scanning begins. Touch [Finish], and then press the [Start] key to begin printing.
 - For details on scanning the document from the original glass, refer to “Scanning a multi-page document from the original glass” on page 3-15.

8.9 Tiling copy images (“Image Repeat” function)

A single document image can be copied repeatedly onto a single sheet of paper. The copies are produced with the number of repeats automatically adjusted according to the document and paper sizes and the zoom ratio.

The following repeating formats and settings are available.

Setting	Description
With Margin	Multiple copies are printed of the entire image within the specified area. The area around the image appears as a margin.
Without Margin	Multiple copies of the selected area of the image are printed to fill the paper; however, a part of the image may be cut off.

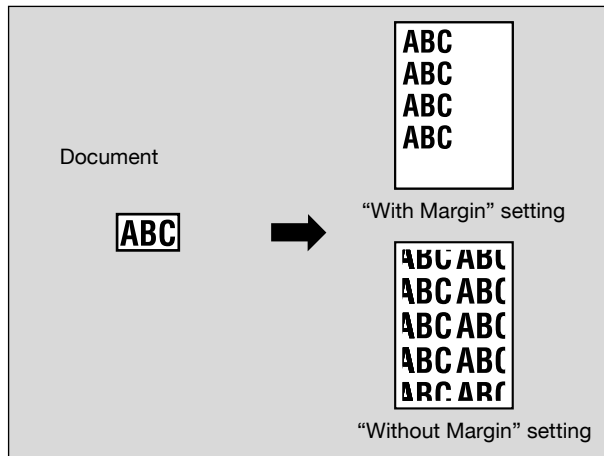

To copy using the “Image Repeat” function

- 1 Position the document to be copied.
 - For details on positioning the document, refer to “Feeding the document” on page 3-7.
- 2 Load the paper to be used into the desired paper tray.
- 3 Touch [Application], and then touch [Book Copy/Repeat].
 - To cancel all settings for the Application functions, touch [Reset].

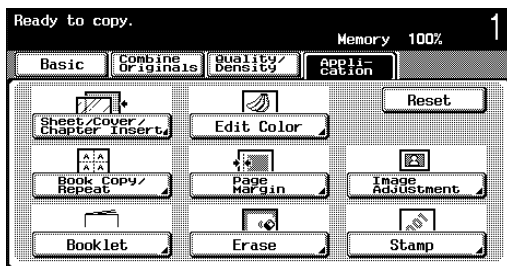

The Book Copy/Repeat screen appears.

- 4 Touch [Image Repeat].

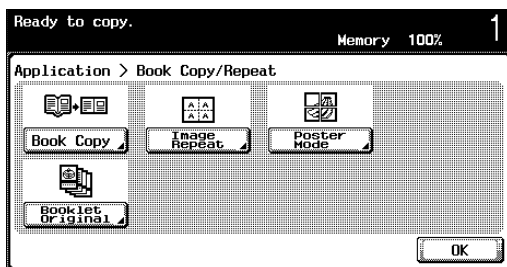

The Image Repeat screen appears.

[Booklet Original] appears if the saddle stitcher is installed on optional finisher FS-514 or optional finisher FS-603 is installed.

- 5 Select the layout method.

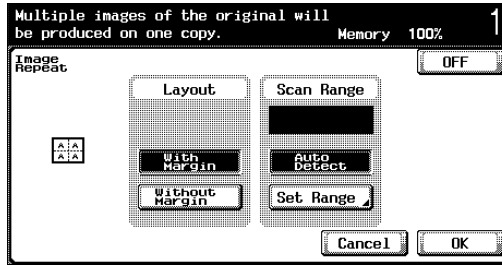

- 6 Check the scanning size under “Scan Range”, touch [OK], and then touch [OK] in the next screen that appears.
- If the document size does not appear under “Scan Range” or to specify the scanning area, touch [Set Range], and then specify the area to be scanned from any of the screens.
 - When the document is loaded into the ADF, the document size is automatically detected when the [Start] key is pressed, so no document size appears under “Scan Range”.
 - To cancel changes to the settings, touch [Cancel].

- To cancel the "Image Repeat" function, touch [OFF].

Standard Size screen

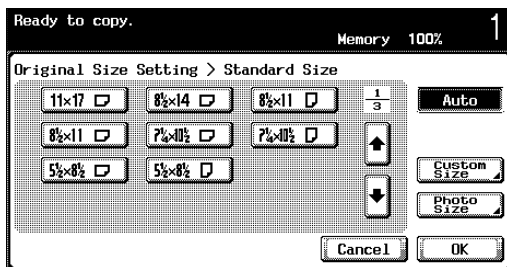

Custom Size screen

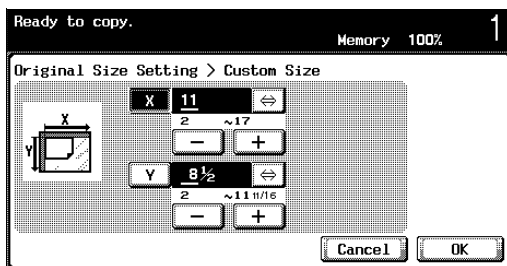
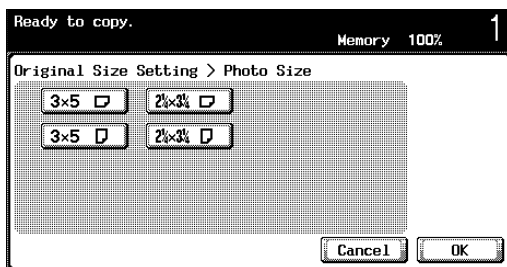

Photo Size screen



- ? Can sizes in metrics be displayed?
- Touch [↕] or [↕] to display a different list of sizes. If [Custom Size] is touched, the Custom Size screen appears. If [Photo Size] is touched, the Photo Size screen appears.

? Can any size be specified?

→ Any size can be specified from the Custom Size screen. Touch [X] or [Y], touch [↔] to switch between the integer and the fraction, and then touch [-] and [+] to specify the dimensions of the scanning area.

If a decimal value is displayed in the screen, press the [C] (clear) key, and then use the keypad to type in the setting. For details on switching between decimal and fraction values, refer to “System setting” on page 12-17.

If a decimal value is displayed in the screen and the specified value is outside the allowable range, the message “Input Error” appears. Type a value within the allowable range. If the value was incorrectly entered, press the [C] (clear) key to erase the value, and then specify the correct value.

- 7 In the Basic screen, touch [Paper], and then select the paper tray loaded with the paper.

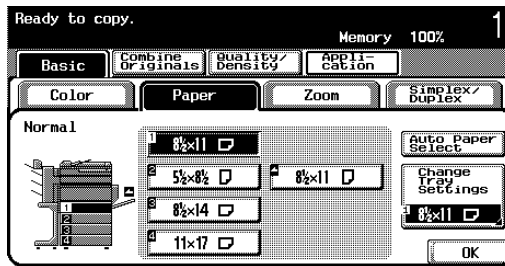

- 8 If necessary, specify any other copy settings.
- 9 Using the keypad, type in the desired number of copies.
- 10 Press the [Start] key.

8.10 Copying an enlarged image on multiple pages (“Poster Mode” function)

A document image can be divided, and each section of the image can be printed enlarged. The finished size can be specified by the image size, zoom ratio or paper size.

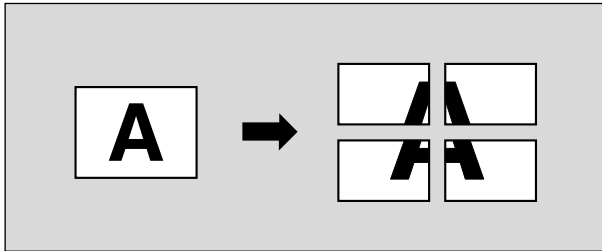

To copy using the “Poster Mode” function

- 1 Position the document onto the original glass.
 - For details on positioning the document, refer to “Feeding the document” on page 3-7.
- 2 Touch [Application], and then touch [Book Copy/Repeat].
 - To cancel all settings for the Application functions, touch [Reset].

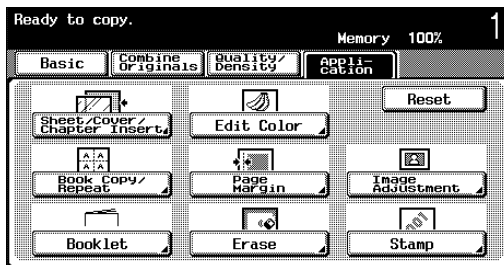

The Book Copy/Repeat screen appears.

3 Touch [Poster Mode].

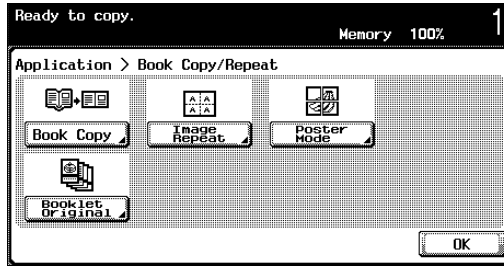

The Poster Mode screen appears.

[Booklet Original] appears if the saddle stitcher is installed on optional finisher FS-514 or optional finisher FS-603 is installed.

4 Touch [Image Size], [Zoom] or [Paper Size] under “Finished Size”.

- The factory default setting for the finished size is “17 × 22”.

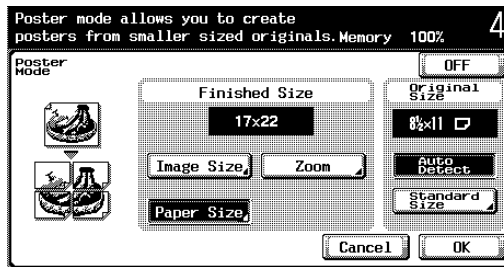

- Touch [Image Size], select the finished image size, and then touch [OK].
- If [Metrics] is touched, a screen containing preset sizes in metrics appears.
- If [Custom Size] is touched, the Custom Size screen appears. Touch [X] or [Y], touch [↔] to switch between the integer and the fraction, and then touch [-] and [+] to specify the desired value.

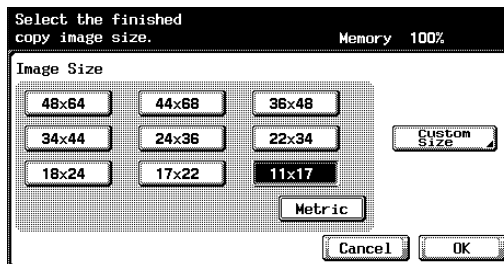

- Touch [Zoom], use the keypad to type in the desired value, and then touch [OK].

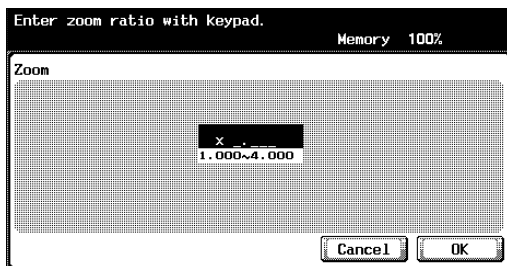

- Touch [Paper Size], select the finished paper size, and then touch [OK].

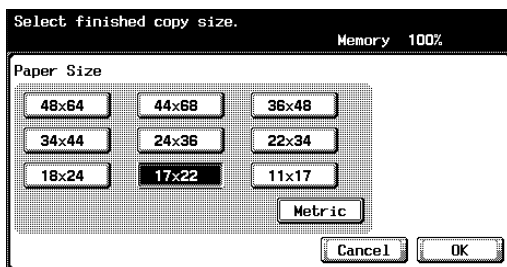

- 5 Check the document size under “Original Size” and then touch [OK]
- If the document size does not appear or to specify the document size, touch [Standard Size] and then specify the document size from any of the screens.
 - When the document is loaded into the ADF, the document size does not appear. If a standard-sized document is loaded, the document size is automatically detected after the [Start] key is pressed. If a non-standard-sized document is loaded, the document size is not detected. Therefore, specify the document size in the Custom Size screen, and then press the [Start] key.

Standard Size screen

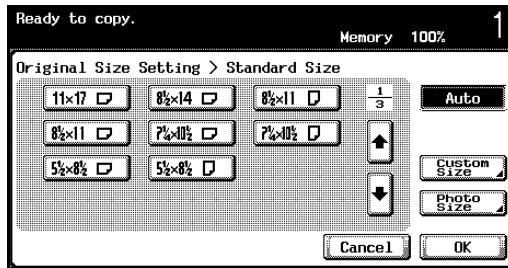

Custom Size screen

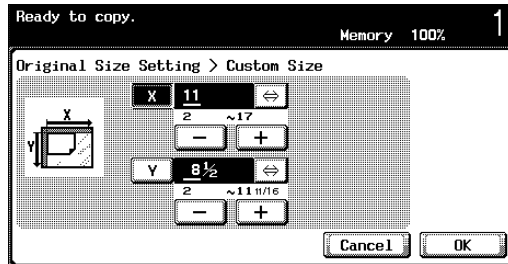
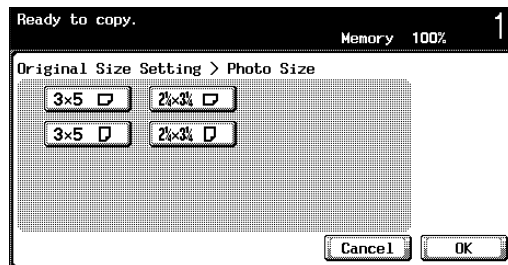



Photo Size screen



? Can sizes in metrics be displayed?
→ Touch [] or [] to display a different list of sizes. If [Custom Size] is touched, the Custom Size screen appears. If [Photo Size] is touched, the Photo Size screen appears.

? Can any size be specified?
→ Any size can be specified from the Custom Size screen. Touch [X] or [Y], touch [↔] to switch between the integer and the fraction, and then touch [-] and [+] to specify the dimensions of the scanning area.

If a decimal value is displayed in the screen, press the [C] (clear) key, and then use the keypad to type in the setting. For details on switching between decimal and fraction values, refer to “System setting” on page 12-17.

If a decimal value is displayed in the screen and the specified value is outside the allowable range, the message “Input Error” appears. Type a value within the allowable range. If the value was incorrectly entered, press the [C] (clear) key to erase the value, and then specify the correct value.

6 If necessary, specify any other copy settings.

The number of copies is set to “1” and cannot be changed.

7 Press the [Start] key.

8.11 Copying with the page layout of a magazine (“Booklet” function)

The page order of the scanned document is automatically arranged to produce double-sided copies in a page layout for center binding, such as for a magazine.

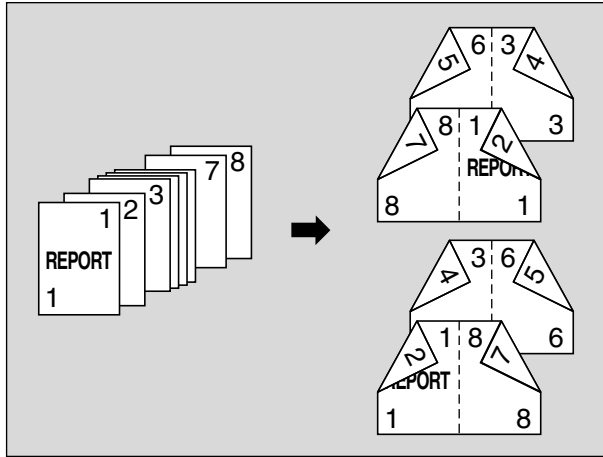

Detail

Generally, a multiple of 4 document pages is required with a single-sided document, and a multiple of 2 document pages is required with a double-sided document. If there are not enough pages, blank pages are automatically added at the end.

For details on stapling, refer to “Specifying center binding” on page 3-80.

For a document that exceeds 100 pages, refer to “Scanning the document in separate batches (“Separate Scan” setting)” on page 3-11.

The binding margin width is automatically specified.

To copy using the “Booklet” function

- ✓ This function is available if the saddle stitcher is installed on optional finisher FS-514 or optional finisher FS-603 is installed.

- 1 Position the document to be copied.
 - For details on positioning the document, refer to “Feeding the document” on page 3-7.
- 2 Touch [Application], and then touch [Booklet].
 - To cancel all settings for the Application functions, touch [Reset].

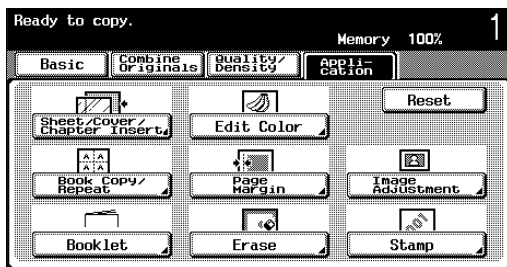

- 3 Touch either [Left Bind] or [Right Bind].
 - If the document contains only pages in the landscape orientation, they will be bound at the top, regardless of which setting is selected.
 - To cancel changes to the settings, touch [Cancel].
 - To cancel the “Booklet” function, touch [OFF].

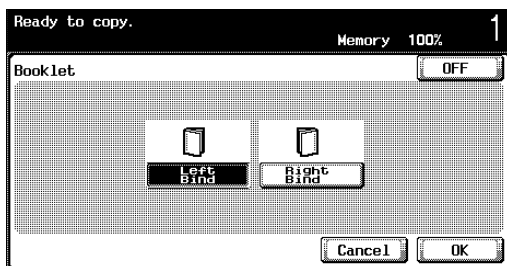

- 4 Touch [OK].
- 5 If necessary, specify any other copy settings.
- 6 Using the keypad, type in the desired number of copies.
- 7 Press the [Start] key.

8.12 Copying with image colors inverted (“Neg-/Pos. Reverse” function)

A document can be copied with the light- and dark-colored areas or the colors (gradations) of the image inverted.

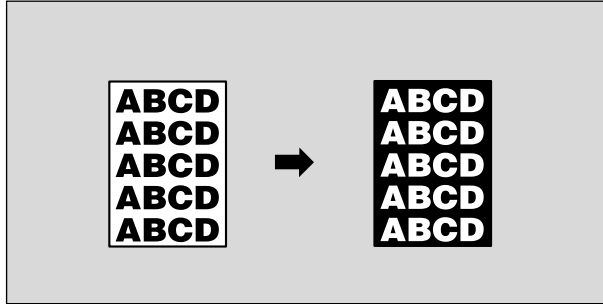

Detail

If the “Single Color” function is set, the colors are inverted with the selected color. If the “Background Color” function is set, the colors, including the selected background color, are inverted.

To copy using the “Neg-/Pos. Reverse” function

- 1 Position the document to be copied.
 - For details on positioning the document, refer to “Feeding the document” on page 3-7.
- 2 Touch [Application], and then touch [Edit Color].
 - To cancel all settings for the Application functions, touch [Reset].

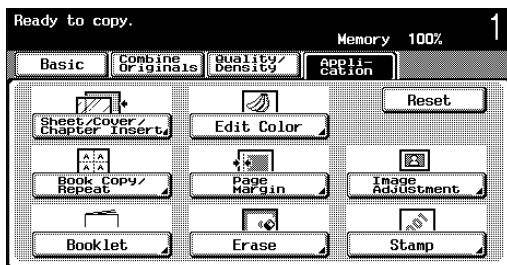

The Edit Color screen appears.

- 3 Touch [Neg-/Pos. Reverse].

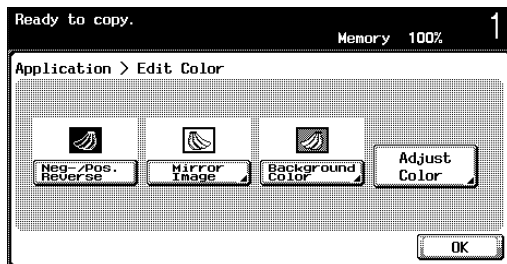

? How is the “Neg-/Pos. Reverse” function canceled?
 → Touch [Neg-/Pos. Reverse] again.

- 4 If necessary, specify any other copy settings.
- 5 Using the keypad, type in the desired number of copies.
- 6 Press the [Start] key.

8.13 Copying in a mirror image (“Mirror Image” function)

A copy can be printed in the mirror image of the original document.

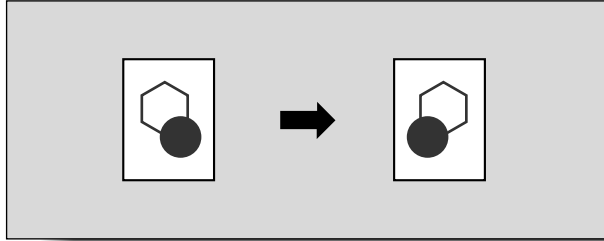

To copy using the “Mirror Image” function

- 1 Position the document to be copied.
 - For details on positioning the document, refer to “Feeding the document” on page 3-7.
- 2 Touch [Application], and then touch [Edit Color].
 - To cancel all settings for the Application functions, touch [Reset].

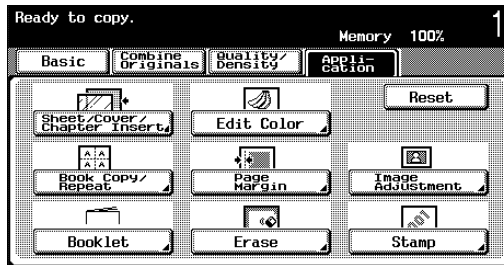

The Edit Color screen appears.

3 Touch [Mirror Image].

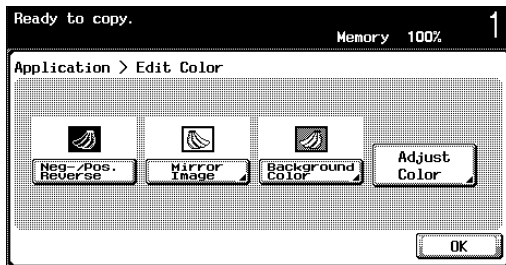

The Mirror Image screen appears.

4 Check the document size under “Original Size”, and then touch [OK].

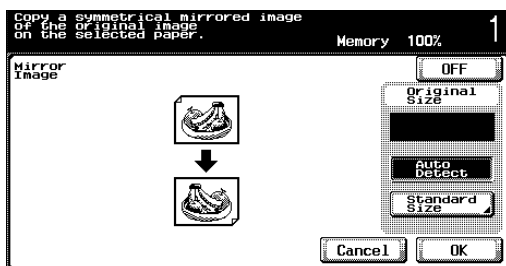

- If the document size does not appear or to specify the document size, touch [Standard Size], and then specify the document size from any of the screens.
- When the document is loaded into the ADF, the document size does not appear. If a standard-sized document is loaded, the document size is automatically detected after the [Start] key is pressed. If a non-standard-sized document is loaded, the document size is not detected. Therefore, specify the document size in the Custom Size screen, and then press the [Start] key.
- To cancel changes to the settings, touch [Cancel].

- To cancel the “Mirror Image” function, touch [OFF].

Standard Size screen

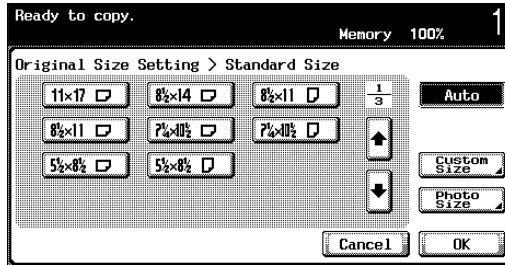

Custom Size screen

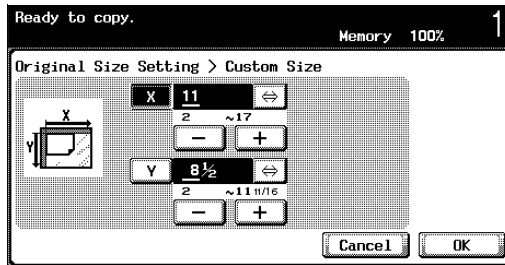
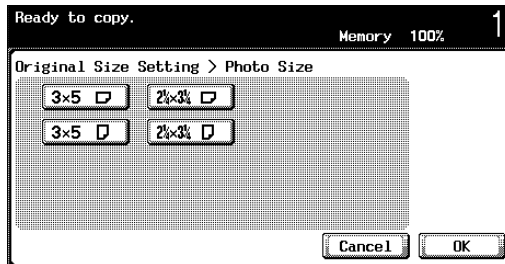

Photo Size screen



- ? Can sizes in inches be displayed?
 → Touch [] or [] to display a different list of sizes. If [Custom Size] is touched, the Custom Size screen appears. If [Photo Size] is touched, the Photo Size screen appears.

? Can any size be specified?

→ Any size can be specified from the Custom Size screen. Touch [X] or [Y], touch [↔] to switch between the integer and the fraction, and then touch [-] and [+] to specify the size of the document.

If a decimal value is displayed in the screen, press the [C] (clear) key, and then use the keypad to type in the setting. For details on switching between decimal and fraction values, refer to “System setting” on page 12-17.

If a decimal value is displayed in the screen and the specified value is outside the allowable range, the message “Input Error” appears. Type a value within the allowable range. If the value was incorrectly entered, press the [C] (clear) key to erase the value, and then specify the correct value.

- 5 If necessary, specify any other copy settings.
- 6 Using the keypad, type in the desired number of copies.
- 7 Press the [Start] key.

8.14 Adding a background color to copies (“Background Color” function)

This function allows you to copy a document using one of the 18 colors available as the color of the background (blank areas).



Detail

For sample images of the “Background Color” function, refer to ““Background Color” function” on page x-45.

To copy using the “Background Color” function

- 1 Position the document to be copied.
 - For details on positioning the document, refer to “Feeding the document” on page 3-7.
- 2 Touch [Application], and then touch [Edit Color].
 - To cancel all settings for the Application functions, touch [Reset].

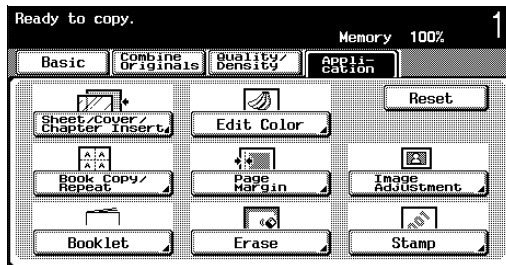

The Edit Color screen appears.

- 3 Touch [Background Color].

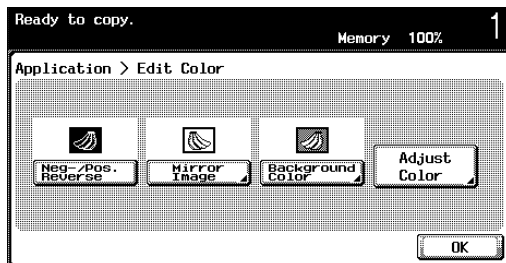

The Background Color screen appears.

4 Select the desired background color.

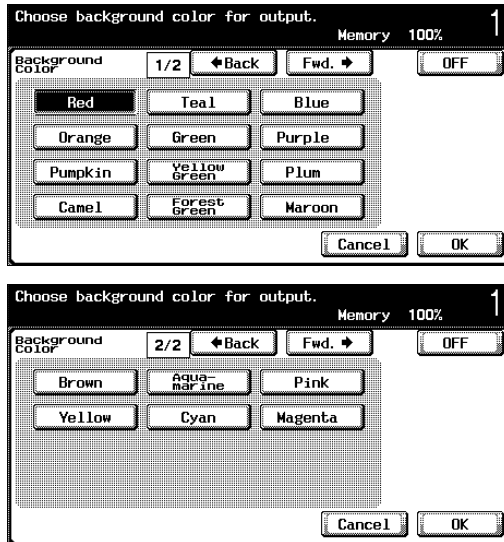

- To cancel changes to the settings, touch [Cancel].
- To cancel the “Background Color” function, touch [OFF].
- ? Can other background colors displayed?
- Touch [←Back] or [Fwd.→] to display a different list of colors.

- 5 Touch [OK].
- 6 If necessary, specify any other copy settings.
- 7 Using the keypad, type in the desired number of copies.
- 8 Press the [Start] key.

8.15 Adjusting the copy color quality (Adjust Color parameters)

You can adjust the quality of color copies as desired.

There are 10 Adjust Color parameters that can be used in any combination. In addition, you can check the specified settings by printing a sample copy.

Setting	Description
Brightness	This parameter can be used to make the image either lighter or darker.
Contrast	This parameter can be used to make the image either crisper or smoother.
Saturation	This parameter can be used to adjust the vividness of the colors in the image.
Red	This parameter can be used to adjust the level of red in the image.
Green	This parameter can be used to adjust the level of green in the image.
Blue	This parameter can be used to adjust the level of blue in the image.
Hue	The hue is divided into red, blue and yellow. By adjusting the hue, the image can be made either more reddish or more bluish.
Copy Density	This parameter can be used to adjust the copy density.
Sharpness	This parameter emphasizes the edges of text so that they can be read more easily. In addition, this parameter can be used to make an overly sharp image softer or a blurry image clearer.
Color Balance	This parameter can be used to adjust the individual concentrations of yellow (Y), magenta (M), cyan (C), and black (K). <ul style="list-style-type: none"> Increasing the amount of yellow and magenta or decreasing the amount of cyan increases the red tinge. Increasing the amount of yellow and cyan or decreasing the amount of magenta increases the green tinge. Increasing the amount of magenta and cyan or decreasing the amount of yellow increases the blue tinge. Increasing the amount of yellow or decreasing the amount of magenta and cyan increases the yellow tinge. Increasing the amount of black increases the black tinge.



Detail

To print a sample copy in order to check the print result with the current settings, touch [Sample Copy]. For details about sample copies, refer to "Checking the Print Result of the Adjust Color Settings (Sample Copy)" on page 8-56.

To adjust the Adjust Color parameters

As an example, the procedure for adjusting the Brightness parameter is described below.

- 1 Touch [Application], and then touch [Edit Color].
 - To cancel all settings for the Application functions, touch [Reset].

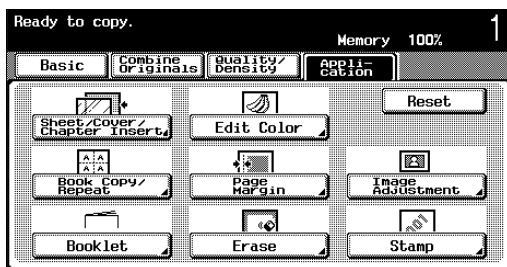

The Edit Color screen appears.

- 2 Touch [Adjust Color].
From the Adjust Color screen, select the desired parameter.

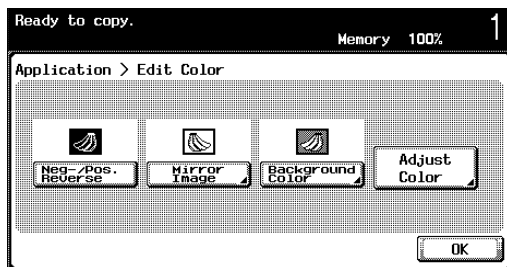

The Adjust Color screen appears.

- 3 Touch [Brightness] in the Adjust Color screen.

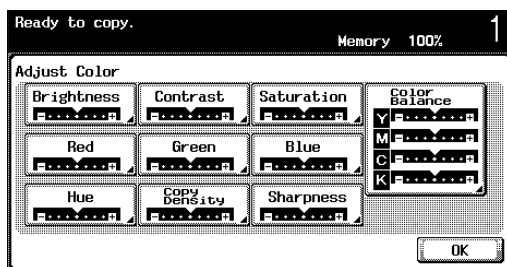

The Darker ↔ Lighter (Brightness) screen appears.

- 4 Touch [◀◀], [◀], [▶], and [▶▶] to change the setting.

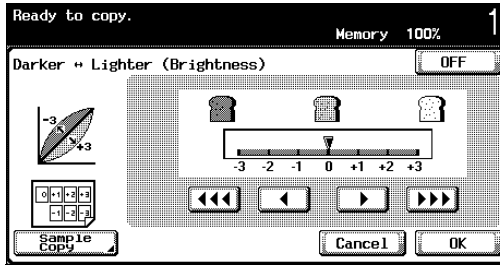

- To cancel changes to the settings, touch [Cancel].
- To cancel the “Brightness” parameter, touch [OFF].
- The “Sharpness” parameter can only be specified in single increments.
- In the Color Balance screen, touch the button for a color, and then specify the adjustment setting.



- How can a setting be specified for the Adjust Color parameter?
 → To change the setting, touch [◀◀], [◀], [▶], and [▶▶] to specify a setting between -3 and +3 in increments of 1 or 1/3.

- 5 Touch [OK], and then touch [OK] in the next screen that appears.



Note

Even though the setting can be specified in increments of 1/3, the setting will appear at the nearest full increment in the Adjust Color screen.

Checking the Print Result of the Adjust Color Settings (Sample Copy)

You can make a sample copy of your document to see how it will appear with the currently specified color adjustment settings.

As an example, the procedure for the Brightness parameter is described below.



Detail

For details on displaying the screen for each Adjust Color parameter, refer to "Adjusting the copy color quality (Adjust Color parameters)" on page 8-53.



Note

[Sample Copy] does not appear in the Color Balance screen.

When the Sample Copy screen is displayed, no key other than [Reset] or [Start] can be used.

Place the document on the original glass with the image to be checked positioned within the sample area. The sample copy will be printed even if the edges of the document extend off the original glass.

To make sample copies

- 1 Touch [Sample Copy] in the Darker ↔ Lighter (Brightness) screen.

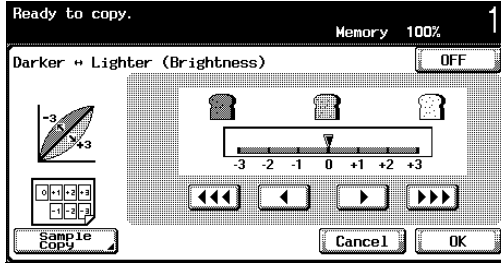

The Sample Copy screen appears.

- 2 Load paper of a size listed under “Paper that can be used” into the paper tray.

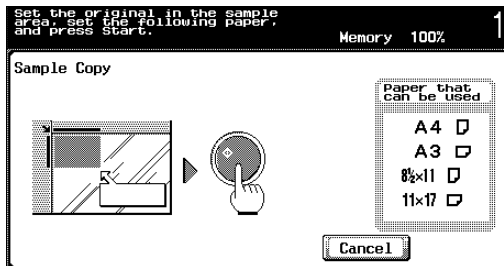

- 3 Place the document within the sample area of the original glass.
- 4 Press the [Start] key.



Note

After the sample copy is printed, the parameter screen appears again.

Each sample copy that is printed is counted in the print counter.

8.16 Adding filing margins to copies (“Page Margin” function)

Copies can be printed with a filing margin so that the pages can easily be filed. When making double-sided copies, the image orientation can be adjusted by specifying the position of the filing margin. In addition, the image orientation can be adjusted without creating a filing margin.

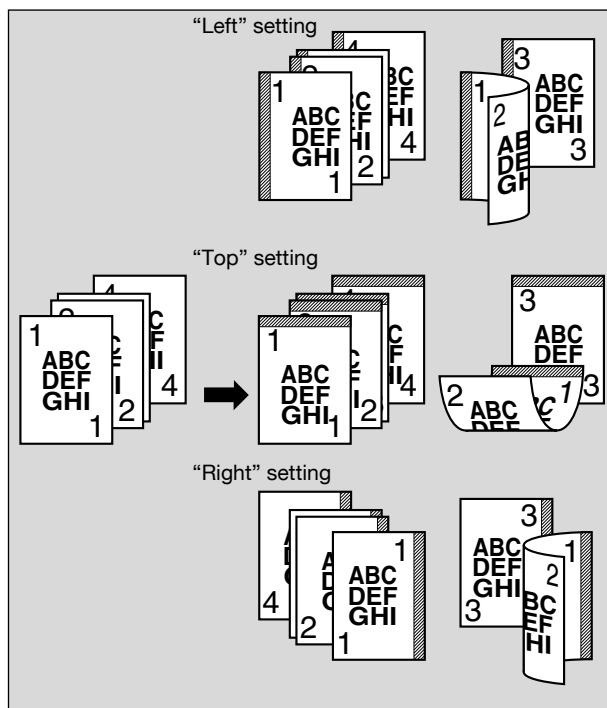

Detail

If the positions of the staples or punched holes are different from the binding position, the positions of the staples or punched holes are given priority.

To copy using the “Page Margin” function

- 1 Position the document to be copied.
 - For details on positioning the document, refer to “Feeding the document” on page 3-7.
- 2 Touch [Application], and then touch [Page Margin].
 - To cancel all settings for the Application functions, touch [Reset].

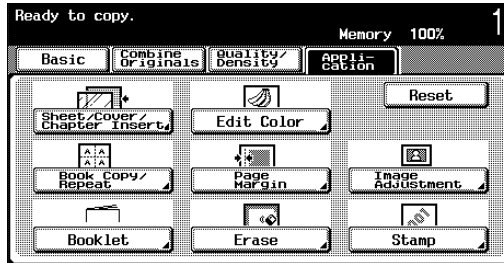

The Page Margin screen appears.

- 3 Specify the position of the filing margin.

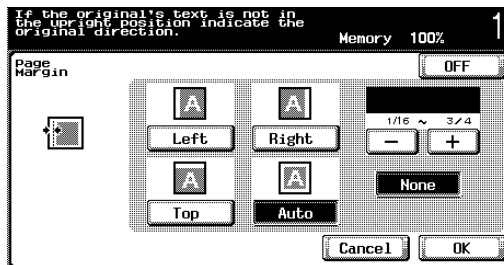

- To cancel changes to the settings, touch [Cancel].
- To cancel the “Page Margin” function, touch [OFF].
- If “Auto” is selected, the binding margin is set at the top or at the left.

? What happens when “Auto” is specified?

- The factory default setting is “Auto”. Touch [Auto] to automatically determine the binding position according to the orientation of the loaded document. If the document length is 11-11/16 in. or less, a binding position along the long side of the paper is selected. If the document length is more than 11-11/16 in., a binding position along the short side of the paper is selected.

- 4 Touch [-] or [+] to specify the margin width.
 - If “None” is selected, the margin width is set to 0 in.. When making double-sided copies, the image orientation can adjusted without creating a filing margin.
 - If a decimal value is displayed in the screen, press the [C] (clear) key, and then use the keypad to type in the setting. For details on switching between decimal and fraction values, refer to “System setting” on page 12-17.
 - If a decimal value is displayed in the screen and the specified value is outside the allowable range, the message “Input Error” appears. Type a value within the allowable range. If the value was incorrectly entered, press the [C] (clear) key to erase the value, and then specify the correct value.
- ? How can the entered margin position be corrected?
 - Without changing the margin width, change the margin position.
- 5 Touch [OK].
- 6 If necessary, specify any other copy settings.
- 7 Using the keypad, type in the desired number of copies.
- 8 Press the [Start] key.

8.17 Erasing specified areas of copies (“Erase” function)

Copies can be produced by erasing unwanted areas around the document, such as the transmission information on received faxes and the shadows of punched holes.

With frame erasing, the same width can be erased along all four sides of the document or a different width can be erased along each side of the document.

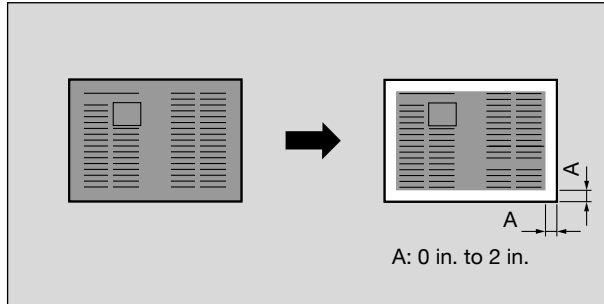

To copy using the “Erase” function

- 1 Position the document to be copied.
 - For details on positioning the document, refer to “Feeding the document” on page 3-7.
- 2 Touch [Application], and then touch [Erase].
 - To cancel all settings for the Application functions, touch [Reset].

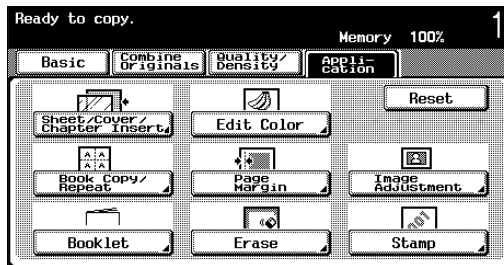

The Erase screen appears.

3 Specify the area to be erased.

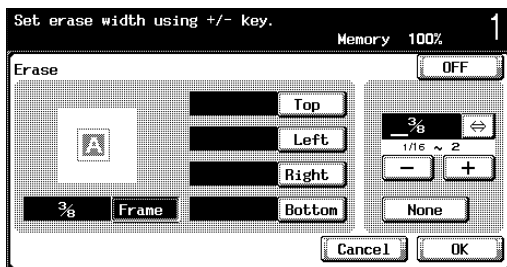

- To cancel changes to the settings, touch [Cancel].
- To cancel the “Erase” function, touch [OFF].
- ? What happens when [Frame] is selected?
 - The same width is erased on all four sides of the document. The factory default setting is “Frame”.
- ? Can the settings be combined?
 - “Frame” cannot be combined with the other settings (“Top”, “Left”, “Right” or “Bottom”).

4 Touch [↔] to switch between the integer and the fraction, and then touch [-] and [+] to specify the width to be erased.

- To specify a different width to be erased depending on the position, specify different settings for “Top”, “Left”, “Right”, and “Bottom”.
- When using the keypad to specify the settings, press the [C] (clear) key, and then specify the setting.
- If a decimal value is displayed in the screen, press the [C] (clear) key, and then use the keypad to type in the setting. For details on switching between decimal and fraction values, refer to “System setting” on page 12-17.
- If a decimal value is displayed in the screen and the specified value is outside the allowable range, the message “Input Error” appears. Type a value within the allowable range. If the value was incorrectly entered, press the [C] (clear) key to erase the value, and then specify the correct value.

5 Touch [OK].

6 If necessary, specify any other copy settings.

7 Using the keypad, type in the desired number of copies.

8 Press the [Start] key.

8.18 Adjusting the image to fit the paper (Image Adjustment settings)

When the copy paper is larger than the original document, copies can be made with the document image centered and enlarged to fill the paper.

The image can be adjusted in any of the following ways.

Setting	Description
Full Size	The area that contains the entire image is centered and enlarged to the size of the paper. "Centering" is also selected automatically.
Center Zoom	The image is enlarged to the size of the paper so that the paper is filled. However, some parts of the image may be lost. "Centering" is also selected automatically.
Centering	The image is centered in the paper without being enlarged.

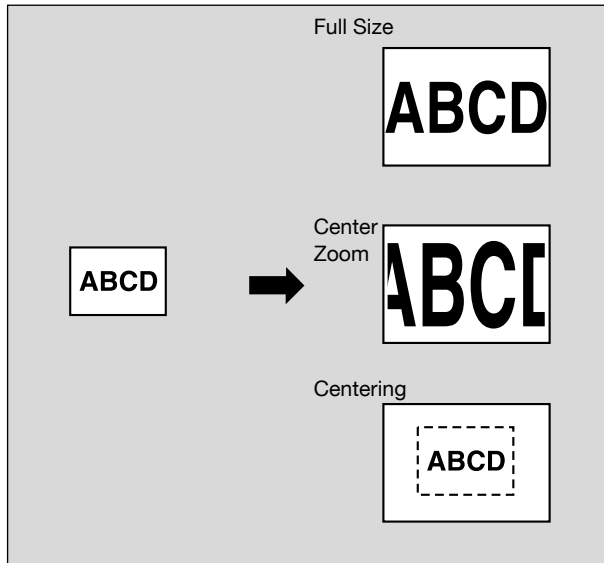

To copy using the Image Adjustment settings

- 1 Position the document to be copied.
 - For details on positioning the document, refer to “Feeding the document” on page 3-7.
 - If “Full Size” or “Center Zoom” is to be set, position the document on the original glass.
- 2 Touch [Application], and then touch [Image Adjustment].
 - To cancel all settings for the Application functions, touch [Reset].

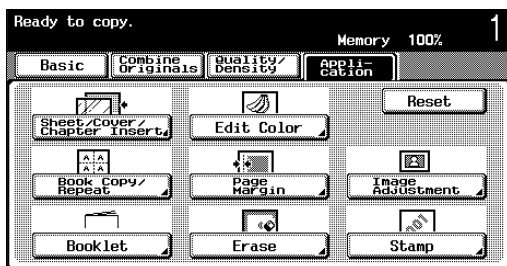

The Image Adjustment screen appears.

- 3 Touch the button for the desired setting.
 - If “Full Size” or “Center Zoom” is selected, “Centering” is also selected.
 - Only “Centering” can also be selected.

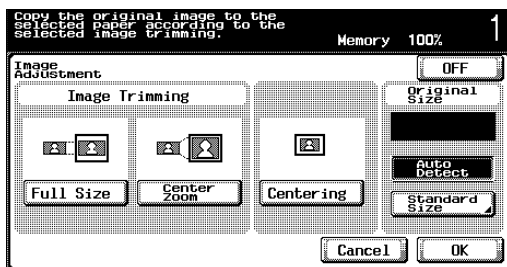

- To cancel changes to the settings, touch [Cancel]
- To cancel the Image Adjustment settings, touch [OFF].

- 4 Check the document size under “Original Size”, and then touch [OK].
- If the document size does not appear or to specify the document size, touch [Standard Size], and then specify the document size from any of the screens.
 - When the document is loaded into the ADF, the document size does not appear. If a standard-sized document is loaded, the document size is automatically detected after the [Start] key is pressed. If a non-standard-sized document is loaded, the document size is not detected. Therefore, specify the document size in the Custom Size screen, and then press the [Start] key.

Standard Size screen

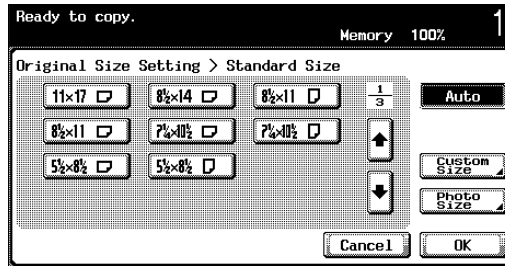

Custom Size screen

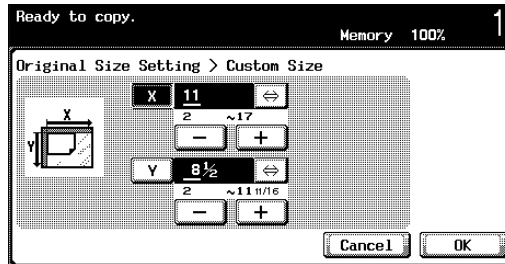
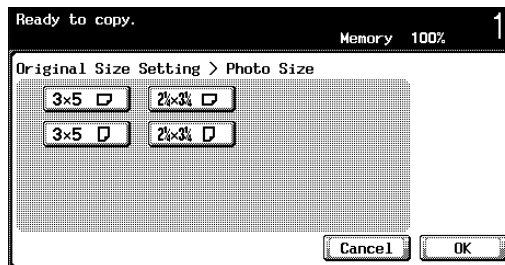



Photo Size screen



? Can sizes in metrics be displayed?
→ Touch [] or [] to display a different list of sizes. If [Custom Size] is touched, the Custom Size screen appears. If [Photo Size] is touched, the Photo Size screen appears.

? Can any size be specified?
→ Any size can be specified from the Custom Size screen. Touch [X] or [Y], touch [↔] to switch between the integer and the fraction, and then touch [-] and [+] to specify the size of the document.

If a decimal value is displayed in the screen, press the [C] (clear) key, and then use the keypad to type in the setting. For details on switching between decimal and fraction values, refer to “System setting” on page 12-17.

If a decimal value is displayed in the screen and the specified value is outside the allowable range, the message “Input Error” appears. Type a value within the allowable range. If the value was incorrectly entered, press the [C] (clear) key to erase the value, and then specify the correct value.

- 5 If necessary, specify any other copy settings.
- 6 Using the keypad, type in the desired number of copies.
- 7 Press the [Start] key.

8.19 Printing the Date/Time, page number or distribution number on copies (Stamp functions)

The date/time or page number can be added to copies at the specified location, or a distribution number can be added when multiple copies are made.

The following Stamp functions are available and can be combined.

Setting	Description	Reference
Date/Time	Select a format and print the date or time on the specified pages.	Refer to p. 8-68.
Page #	Select a format and print page numbers starting with the specified page number.	Refer to p. 8-71.
Set Numbering	Print a four-digit distribution number in the background of each set of copies.	Refer to p. 8-75.
Copy Protect	Print copies with copy protection text (hidden text that prevents improper copying), such as a preset stamp or the date.	Refer to p. 8-77.

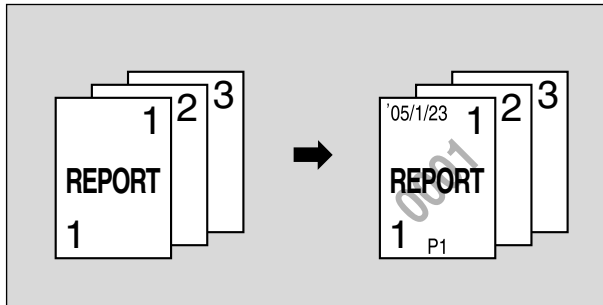

Printing the Date/Time (“Date/Time” function)

To copy using the “Date/Time” function

- 1 Position the document to be copied.
 - For details on positioning the document, refer to “Feeding the document” on page 3-7.
- 2 Touch [Application], and then touch [Stamp].
 - To cancel all settings for the Application functions, touch [Reset].

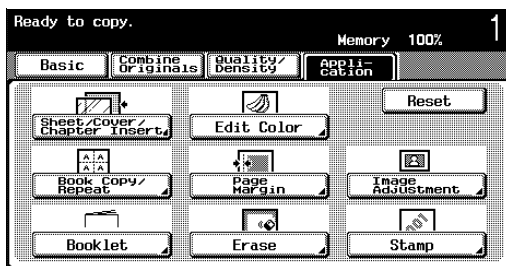

The Stamp screen appears.

- 3 Touch [Date/Time].

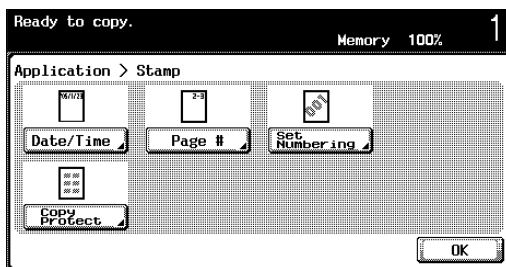

The Date/Time screen appears.

- 4 Touch the buttons for the desired settings under “Date Type”, “Time Type” and “Pages”.

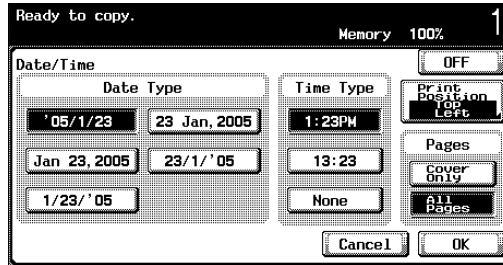

- To cancel changes to the settings, touch [Cancel].
- To cancel the “Date/Time” function, touch [OFF].
- To print the stamp only on the front cover page, touch [Cover Only].
- The stamp will not be printed on blank pages inserted using the “Cover Mode”, “Insert Sheet” and “Chapters” functions.

? Can the time be omitted?

→ If “None” is selected, the time is not printed.

- 5 Touch [Print Position], and then select the printing position.

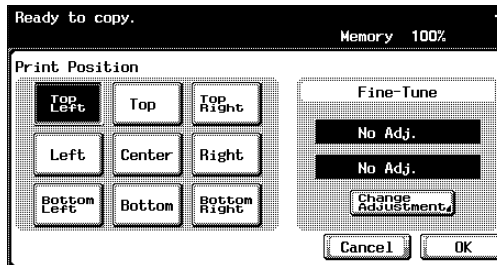

- To make fine adjustments to the printing position, touch [Change Adjustment]. Select the desired direction under “Left & Right Adjustment” or “Top & Bottom Adjustment”, touch [←→] to switch between the integer and the fraction, touch [-] and [+] to specify the adjustment amount, and then touch [OK].
- If a decimal value is displayed in the screen, press the [C] (clear) key, and then use the keypad to type in the adjustment amount. For details on switching between decimal and fraction values, refer to “System setting” on page 12-17.

- If a decimal value is displayed in the screen and the specified value is outside the allowable range, the message "Input Error" appears. Type a value within the allowable range. If the value was incorrectly entered, press the [C] (clear) key to erase the value, and then specify the correct value.

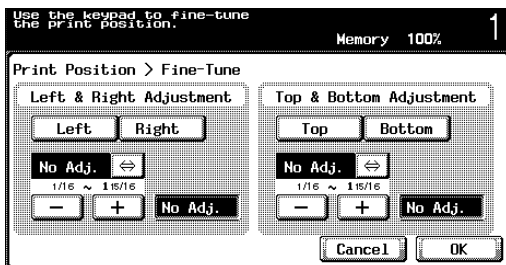

- ? What are the limits on the adjustment amount?
→ The print position can be finely adjusted in 1/16-in. increments.
- ? Can no adjustments be made?
→ To make no left/right or up/down adjustments, touch [No Adj.].

- 6 Touch [OK], and then touch [OK] in the next screen that appears.
- 7 If necessary, specify any other copy settings.
- 8 Using the keypad, type in the desired number of copies.
- 9 Press the [Start] key.

Printing the page number (“Page #” function)

To copy using the “Page #” function

- 1 Position the document to be copied.
 - For details on positioning the document, refer to “Feeding the document” on page 3-7.
- 2 Touch [Application], and then touch [Stamp].
 - To cancel all settings for the Application functions, touch [Reset].

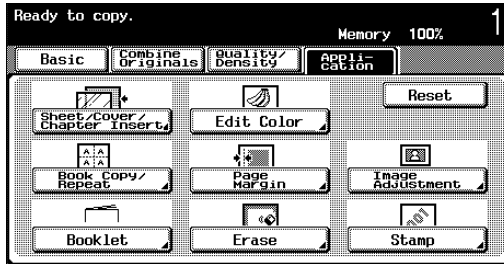

The Stamp screen appears.

- 3 Touch [Page #].

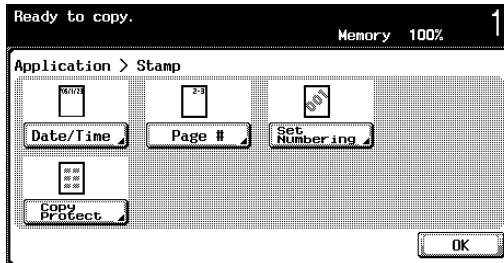

The Page # screen appears.

4 Using the keypad, type in the starting page number.

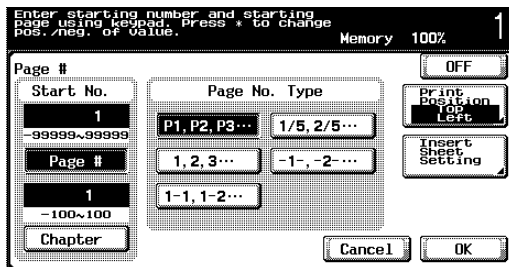

- If necessary, touch [Chapter], and then use the keypad to type in the chapter number.
- The setting for “Page #” can be set to a number between –99999 and 99999, and the setting for “Chapter” can be set to a number between –100 and 100. When specifying a starting number, switch the number between positive and negative by pressing the [*] key. If a negative value is specified, the numbers are not printed until the numbering reaches 1. For example, if “–1” was specified, the numbers are printed starting with “1” on the third copied page.
- To cancel changes to the settings, touch [Cancel].
- To cancel the “Page #” function, touch [OFF].

5 Specify the page number format.

6 Touch [Print Position], and then select the printing position.

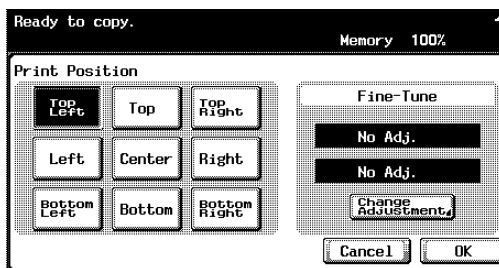

- To make fine adjustments to the printing position, touch [Change Adjustment]. Select the desired direction under “Left & Right Adjustment” or “Top & Bottom Adjustment”, touch [↔] to switch between the integer and the fraction, touch [-] and [+] to specify the adjustment amount, and then touch [OK].
- If a decimal value is displayed in the screen, press the [C] (clear) key, and then use the keypad to type in the adjustment amount. For details on switching between decimal and fraction values, refer to “System setting” on page 12-17.

- If a decimal value is displayed in the screen and the specified value is outside the allowable range, the message “Input Error” appears. Type a value within the allowable range. If the value was incorrectly entered, press the [C] (clear) key to erase the value, and then specify the correct value.

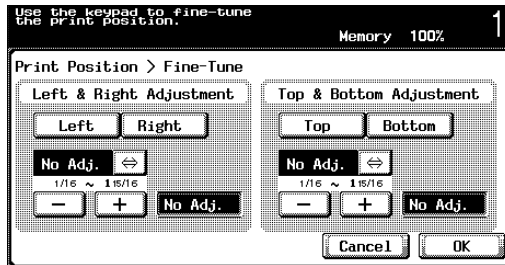

- To also specify settings for Application functions “Cover Mode”, “Insert Sheet” and “Chapters”, touch [Insert Sheet Setting], and then select the settings for the pages to be printed.

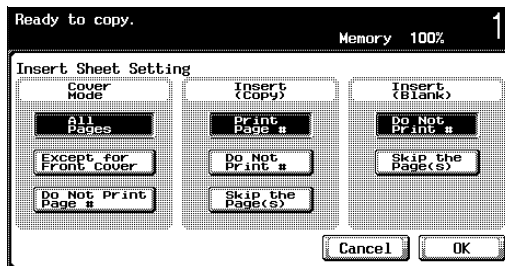

- Blank pages inserted using the “Cover Mode”, “Insert Sheet” and “Chapters” functions are only counted, but page numbers are not printed on them.
- If “Except for Front Cover” or “Do Not Print Page #” is selected under “Cover Mode”, page numbers are printed starting with “2” in single-sided copies and starting with “3” in double-sided copies.
- If “Do Not Print Page #” is selected, inserted pages are only counted, but page numbers are not printed on them. If “Skip the page(s)” is selected, inserted pages are not counted and page numbers are not printed on them.
- ? What are the limits on the adjustment amount?
 - The print position can be finely adjusted in 1/16-in. increments.
- ? Can no adjustments be made?
 - To make no left/right or up/down adjustments, touch [No Adj.].

- 7 Touch [OK], and then touch [OK] in the next screen that appears.
The Stamp screen appears again.
- 8 If necessary, specify any other copy settings.
- 9 Using the keypad, type in the desired number of copies.
- 10 Press the [Start] key.

Printing the distribution number (“Set Numbering” function)



Detail

The distribution number is normally printed as a four-digit number. If “Start Number” is set to “1”, “0001” is printed.

To copy using the “Set Numbering” function

- 1 Position the document to be copied.
 - For details on positioning the document, refer to “Feeding the document” on page 3-7.
- 2 Touch [Application], and then touch [Stamp].
 - To cancel all settings for the Application functions, touch [Reset].

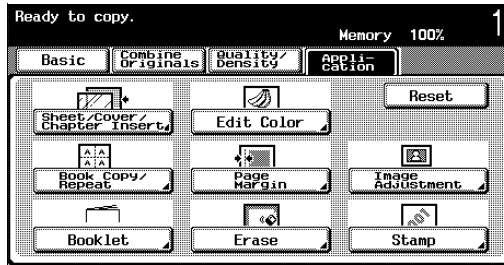

The Stamp screen appears.

- 3 Touch [Set Numbering].

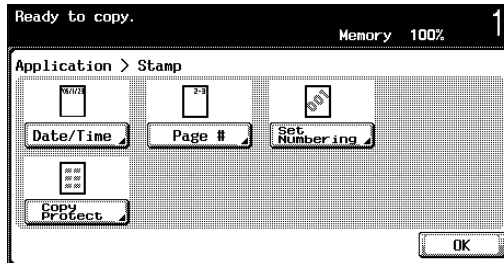

The Set Numbering screen appears.

- 4 Using the keypad, type in the starting number.
- The starting number can be set between 0 and 9999.
 - To print the stamp only on the front cover page, touch [Cover Only].
 - The stamp will not be printed on blank pages inserted using the “Cover Mode”, “Insert Sheet” and “Chapters” functions.

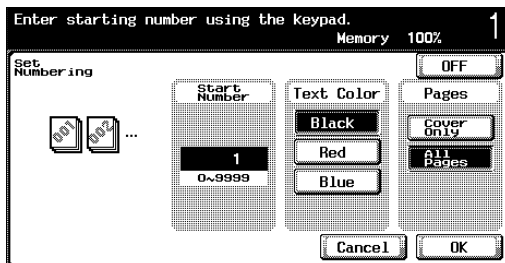

- To cancel changes to the settings, touch [Cancel].
 - To cancel the “Set Numbering” function, touch [OFF].
- 5 Touch a button under “Text Color” and under “Pages” to specify the desired settings.
- Pages printed with the “Black” Color setting and “Red” or “Blue” selected under “Text Color” are counted as 2-color prints.
 - If the color of the stamp text is different from the second color selected when “Color” was set to “2 Color”, copies are included in the Full Color counter.
- 6 Touch [OK].
- 7 If necessary, specify any other copy settings.
- 8 Using the keypad, type in the desired number of copies.
- 9 Press the [Start] key.

Printing copy protection text (“Copy Protect” function)

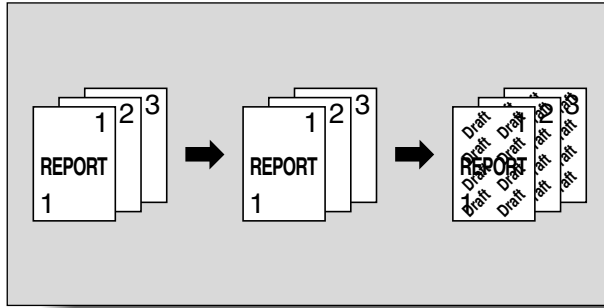

Detail

If the “Copy Protect” function is set, hidden text is printed in order to prevent improper copying. When a document printed with copy protection text is copied, the hidden text appears clearly repeated in the copies so that the reader knows that it is a copy.

The copy protection text is printed on all pages. Specific pages cannot be specified.

To copy using the “Copy Protect” function

- 1 Position the document to be copied.
 - For details on positioning the document, refer to “Feeding the document” on page 3-7.
- 2 Touch [Application], and then touch [Stamp].
 - To cancel all settings for the Application functions, touch [Reset].

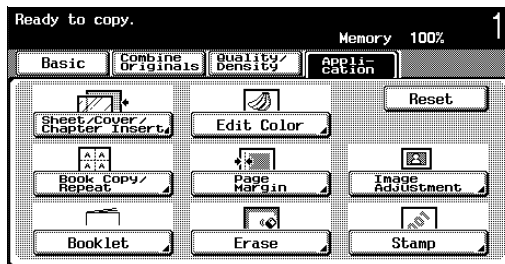

The Stamp screen appears.

3 Touch [Copy Protect].

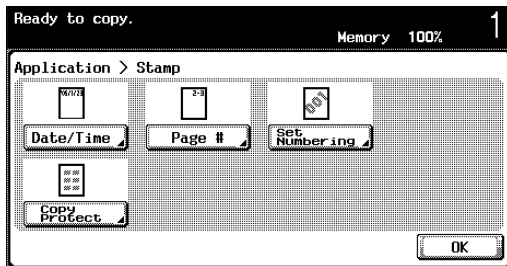

The Copy Protect screen appears.

4 Select the format for the copy protection text.

- To cancel the “Copy Protect” function, touch [OFF]. Touching [OFF] in the settings screen for the format of copy protection text only cancels the settings in that screen.
- The selected copy protection text formats appear in a column at the center of the screen. Up to eight text lines can be combined.
- If more than eight text lines are selected, the new ones are added at the top of the column, replacing the ones at the bottom.

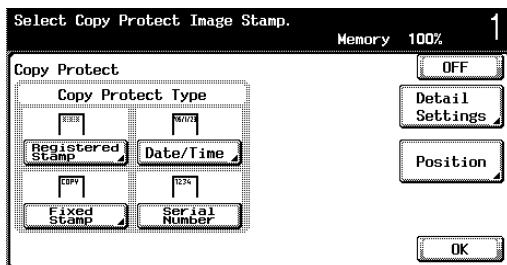

- If [Registered Stamp] or [Fixed Stamp] was touched, a screen containing buttons for the available stamps appears. Touch the button for the desired stamp, and then touch [OK].
- To cancel changes to the settings, touch [Cancel].

- Multiple registered stamps or preset stamps cannot be selected.

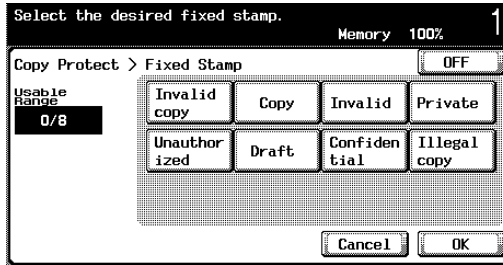

- If [Date/Time] was touched, the Copy Protect>Date/Time screen appears. Select the desired settings under “Date Type” and “Time Type”, and then touch [OK].
- The copy protection date and time that is printed is the date and time when the document is scanned.

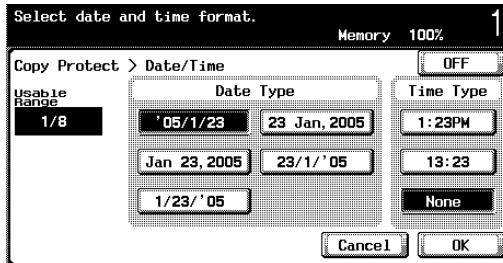

- If [Serial Number] key is touched, the serial number for this machine is printed.
- For details on specifying the serial number, contact your technical representative.
- If necessary, touch [Detail Settings], and then change the copy protection settings. Touch the desired button in the Copy Protect>Detail Setting screen, and then change the setting in the screen that appears.

- The factory default settings are listed below.
[Color]: Black, [Density]: Standard, [Pattern]: Embossed (Pattern Contrast 0), [Size]: Normal, [Pattern Overwrite]: Front

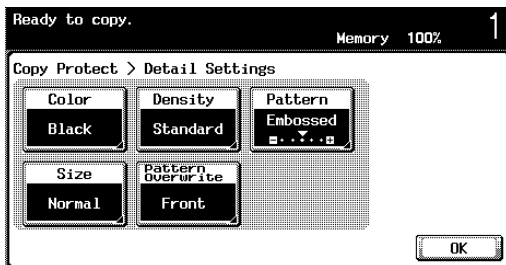

Color screen

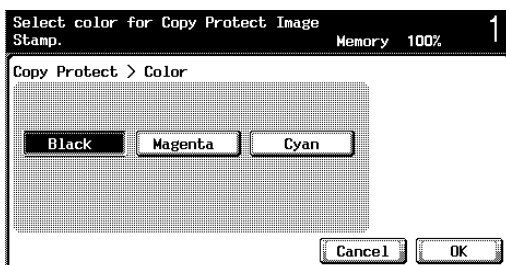

Density screen

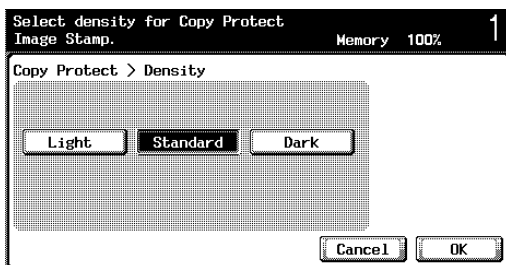

Pattern screen

- The settings under “Pattern Contrast” in the Pattern screen can only be specified in single increments between -2 and +2.

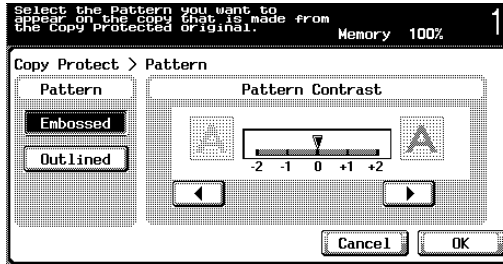

Pattern Size screen

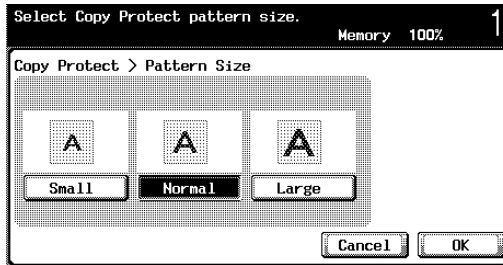

Pattern Overwrite screen

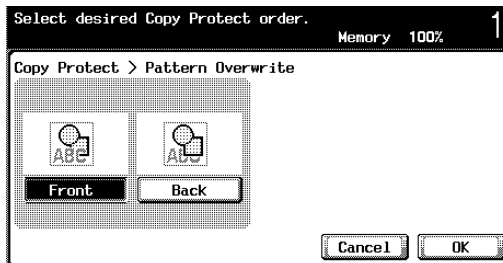

- If necessary, touch [Position], and then change the printing angle in the Position screen. Select desired angle, and then touch [OK].

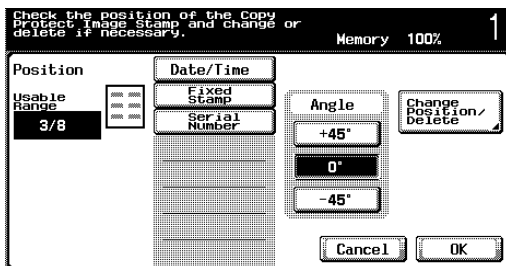

- If necessary, touch [Change Position/Delete] in the Position screen, and then change the arrangement of the text in the Position Change/Delete screen.
- If there are no more than four lines in the selected copy protection text, the angle can be changed.
- To change the arrangement, touch [Change Position], select the copy protection text to be moved, and then touch either [Up] or [Down].

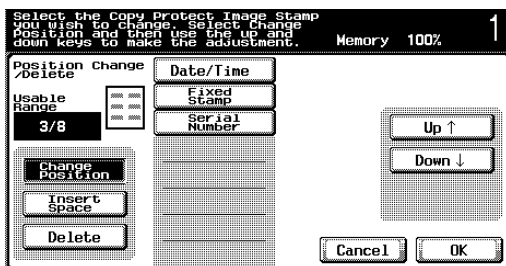

- To add space to the copy protection text, touch [Insert Space]. Touch either [Up] or [Down] to move the arrow that appeared beside the specified formats for the copy protection text, and then touch [Insert].

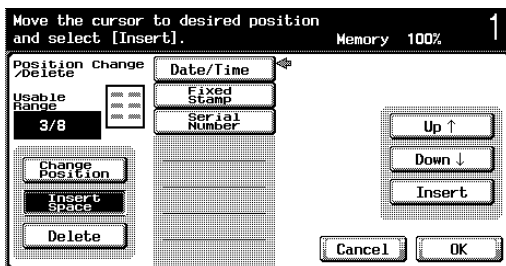

- To delete the copy protection text, touch [Delete], and then touch the button for the copy protection text to be deleted.

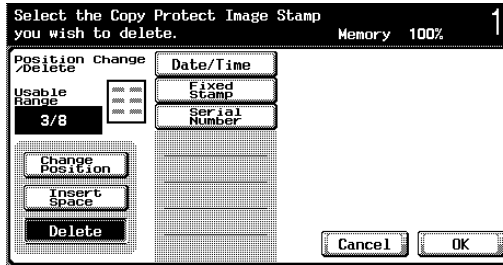

- 5 Touch [OK].
- 6 If necessary, specify any other copy settings.
- 7 Using the keypad, type in the desired number of copies.
- 8 Press the [Start] key.



Note

If the document is a single color and "Magenta" or "Cyan" was selected as the color for the copy protection text, the copies will be counted as having two colors in the Total counter. The same will occur if the document is a single color other than black and the color for the copy protection text is set to "Black".

9

Replacing toner cartridges and staples and emptying waste containers

9 Replacing toner cartridges and staples and emptying waste containers

9.1 Replacing the toner cartridge

When the toner is about to run out, the advanced warning message shown below appears.



Detail

About 1000 (8-1/2 × 11) pages can be printed after the message “Toner Cartridge (X) needs to be replaced soon.” appears.

When the message appears, prepare to replace the toner cartridge according to your maintenance agreement.

When the message “There is no toner.” appears, the machine stops operating.

When the toner is empty, the warning message shown below appears and copies can no longer be made.

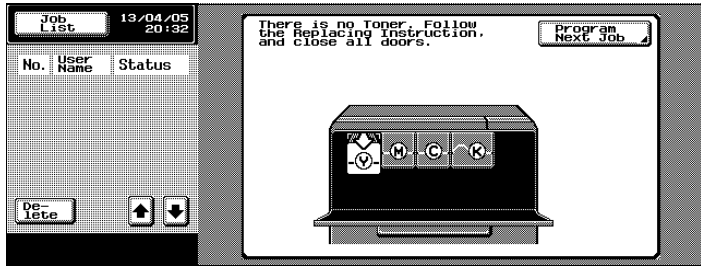

...

Note

When the message appears, replace the toner cartridge according to your maintenance agreement.

**Detail**

For details on replacing the toner cartridges, refer to "To replace the toner cartridge" on page 9-6.

Display in Enlarge Display mode

When the toner is empty, the screen shown below appears.

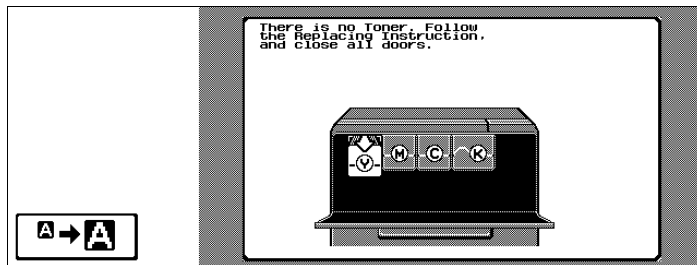

Touch  to display the message shown below.

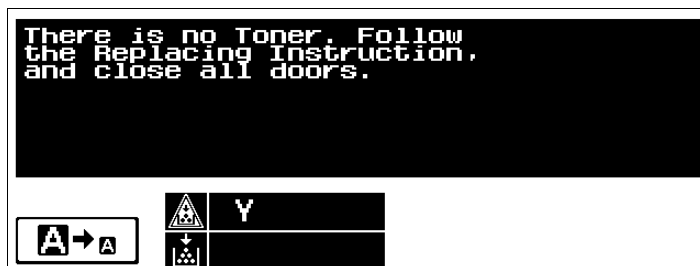

CAUTION

Handling toner and the toner cartridges

- Do not throw toner or the toner cartridge into a fire.
- Toner expelled from the fire may cause burns.

 **CAUTION****Precautions for toner spills**

- Be careful not to spill toner inside the machine or get toner on your clothes or hands.
 - If your hands become soiled with toner, immediately wash them with soap and water.
 - If toner gets in your eyes, immediately flush them with water, and then seek professional medical attention.
-

**Reminder**

Do not replace the toner cartridge until the message "There is no Toner." appears. In addition, do not replace the toner cartridge of any color other than the one indicated in the message on the touch panel.

To replace the toner cartridge

The procedure for replacing any of the toner cartridges (yellow (Y), magenta (M), cyan (C) or black (K)) is the same.

Example: Replacing the black toner cartridge

- ✓ When replacing the black toner cartridge, be sure to replace filter 2. A new filter 2 is included in the package with the black toner cartridge.

- ✓ When replacing the black toner cartridge, be sure to clean the electrostatic charger wire.

For details on cleaning the electrostatic charger wire, refer to “Electrostatic charger wire” on page 10-6.

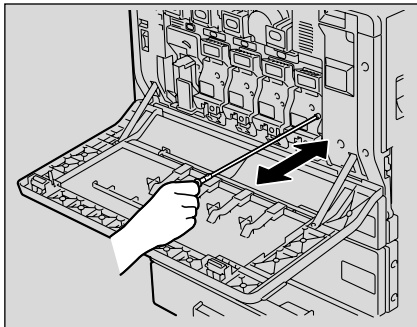

- 1 Open the machine's front door.

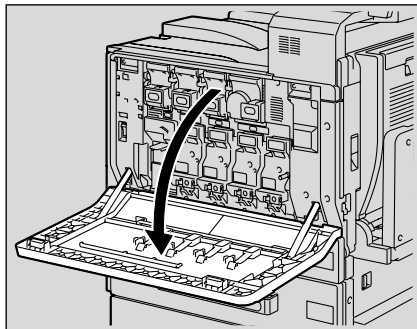

- 2 Pull up the locking tab of the empty toner cartridge to unlock it. Pull out the toner cartridge as far as possible, and then pull it up to remove it.

? How are used toner cartridge disposed of?

- Do not throw away used toner cartridges. Instead, keep them in their boxes to be collected by your technical representative.

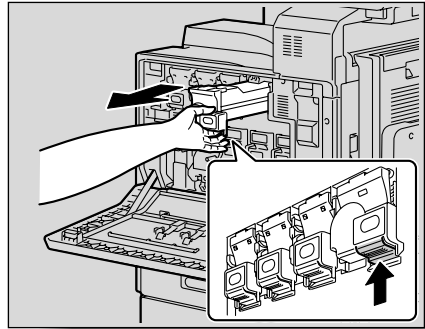

- 3 Prepare the new toner cartridge.

- Make sure that the toner cartridge is the same color as the label in the cartridge compartment.

? Can a toner cartridge of a different color be installed?

- The toner cartridge of a color different than the one that was removed cannot be installed. If the wrong toner cartridge is installed with extreme force, the machine may be damaged.

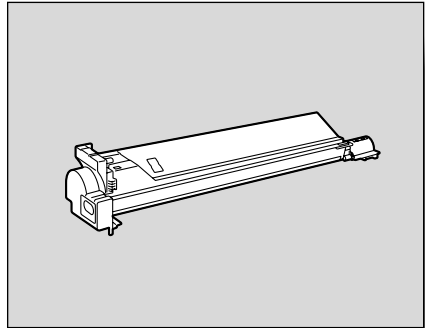

- 4 Remove the new toner cartridge from its packaging, and then shake the cartridge up and down 5 to 10 times.

- The toner within the toner cartridge may have become compacted. If it has, be sure to shake the toner cartridge until the toner is mostly broken up before installing the cartridge.

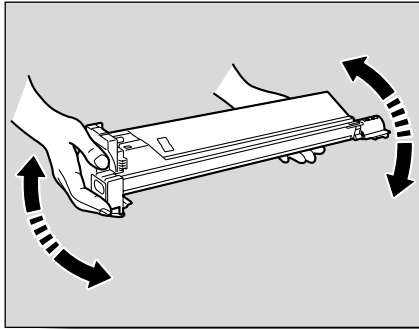

- 5 Align the toner cartridge with the slots in the machine, and then insert the cartridge until the locking tab locks into place.

- When inserting the new toner cartridge, fully insert it until it snaps into place.

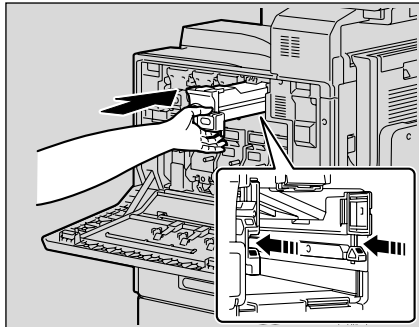

- 6 Close the front door.

- ? Why can't the door be closed securely?
- Check that the toner cartridge is fully inserted.

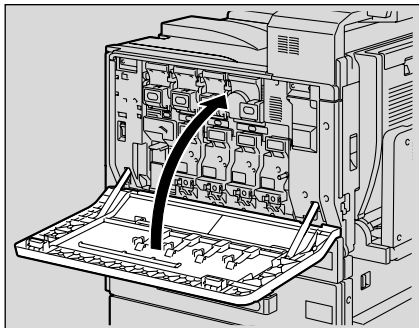



...

Note

Check that a toner cartridge of the same color as the one to be replaced has been prepared.



...

Reminder

Be careful about the installation location of the toner cartridges, since it is different for other colors.

The shape of the black toner cartridge is different from the shapes of the toner cartridges for the other colors.

When installing the new filter 2, fully insert it until it snaps into place.

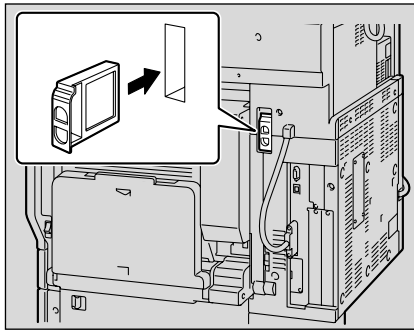

9.2 Replacing the staples

When finisher is installed and is about to run out of staples, the message shown below appears.

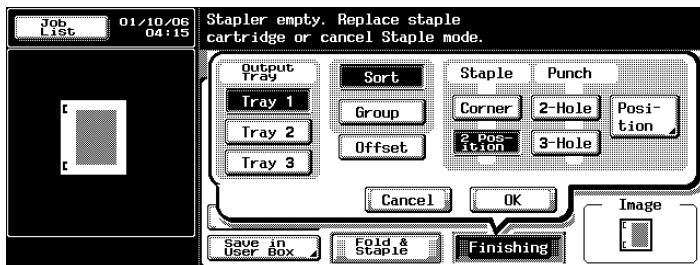

Display in Enlarge Display mode



Detail

Be sure to replace the staple cartridge only after the message appears, otherwise the machine may be damaged.

To replace the staple cartridge in the finisher FS-514

- 1** Open the front door.

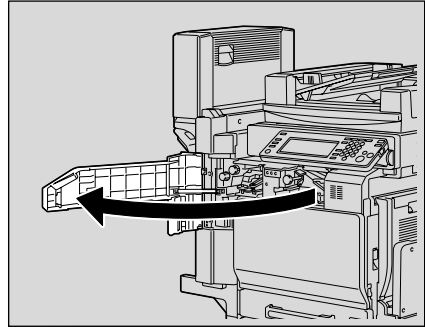

- 2** Remove the staple cartridge holder.
- Pull the staple cartridge holder toward you to remove it.
 - Only touch the blue parts of the staple cartridge.

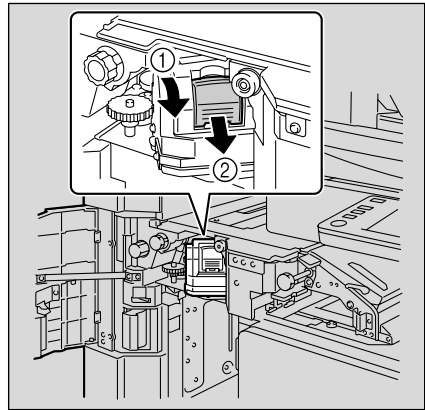

- 3** Remove the empty cartridge from the staple cartridge holder.

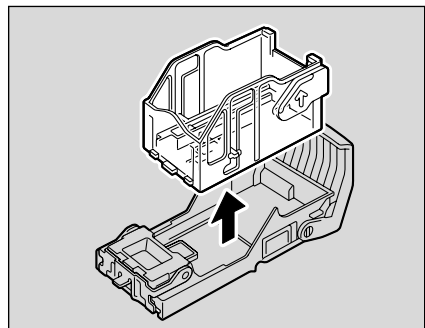

- 4 Load the new staple cartridge into the staple cartridge holder.

- Do not remove the remaining staples, otherwise the machine will not be able to staple after the cartridge is replaced.

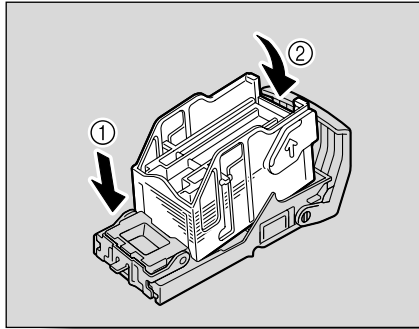

- 5 Insert the staple cartridge holder, making sure the tabs on the holder slide along the rails in the compartment.

- Check that the staple cartridge holder is securely installed.

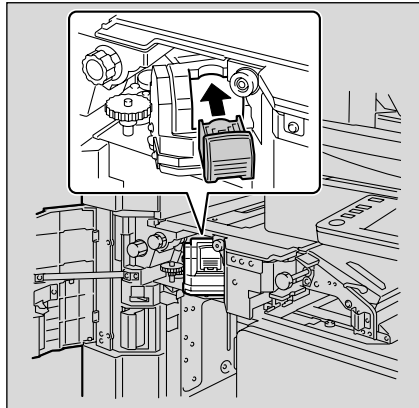

- 6 Close the front door.



Reminder

Replace the staple cartridge only after the message has appeared.

If the staple cartridge is replaced before the message appears, the machine may be damaged.

To replace the staple cartridge in saddle stitcher

- 1 Raise the copy output tray, and then push down the staple cartridge holder and remove it.

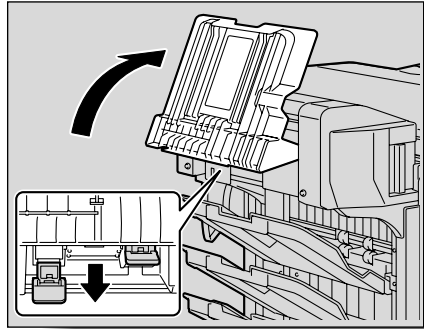

- 2 Press in the area marked "PUSH" to unlock the staple cartridge holder.

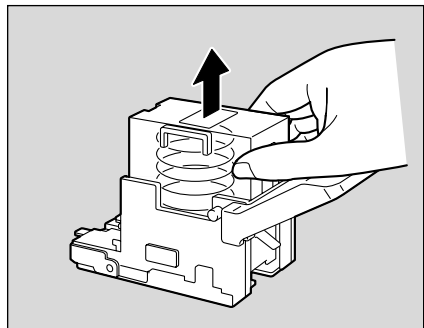
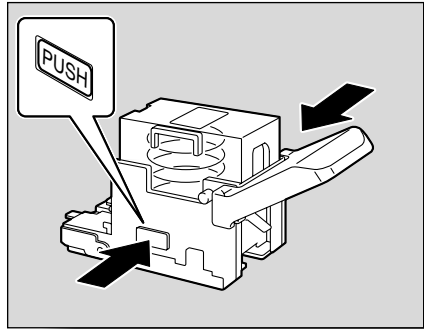

- 3 Remove the empty staple cartridge from the staple cartridge holder.

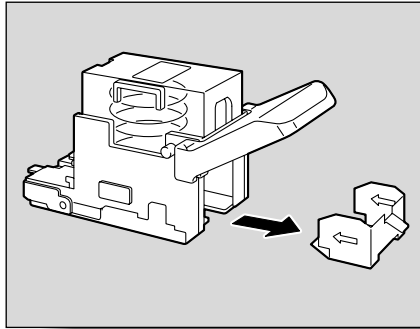

- 4 Load the new staple cartridge into the staple cartridge holder.

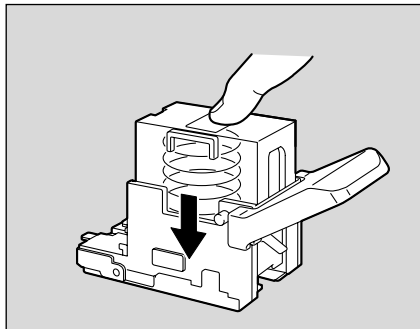
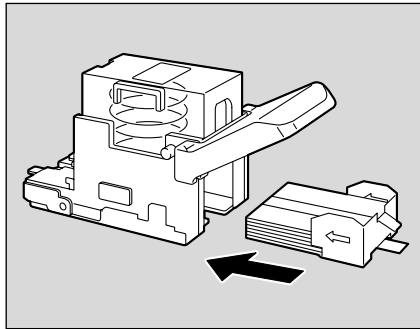

- 5 Slowly pull off the seal.

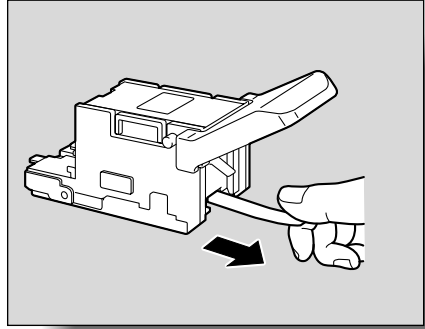

- 6 Insert the staple cartridge holder, and then push it up until it locks into place.
- When inserting the staple cartridge holder, be sure to insert it so that it faces the correct direction.

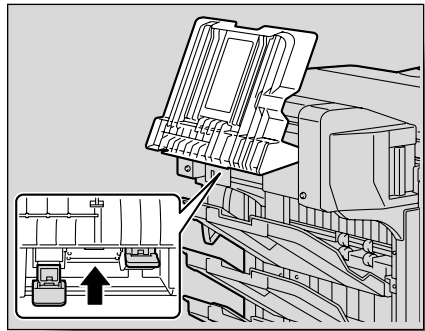

- 7 Return the copy output tray to its original position.

- 8 Pull the handle of the misfeed-clearing door to open it, and then close it.

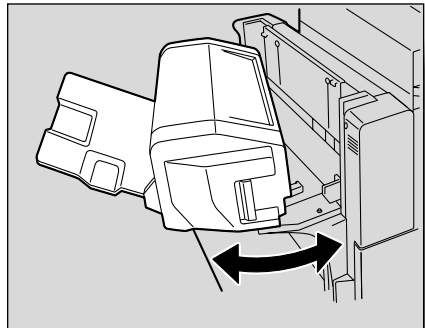

To replace the staple cartridge for finisher FS-501

- 1 Slide the finisher away from the machine.

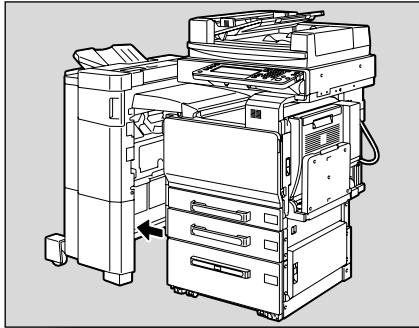

- 2 Turn the jammed-staple-clearing dial to the left in order to position stapler at the center.

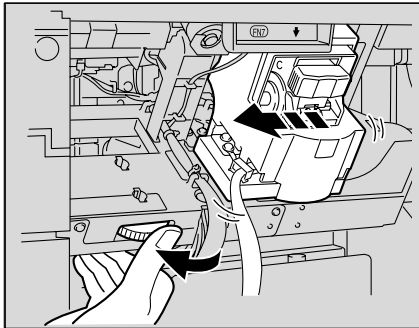

- 3 Pull the staple cartridge holder toward you from stapler, as described in the touch panel messages.

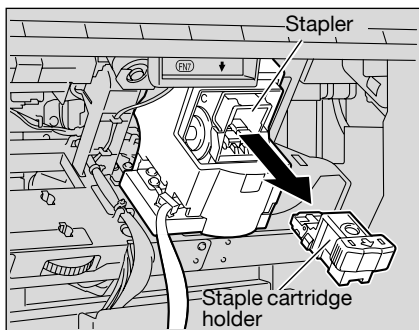

- 4 Remove the staple cartridge from the staple case.

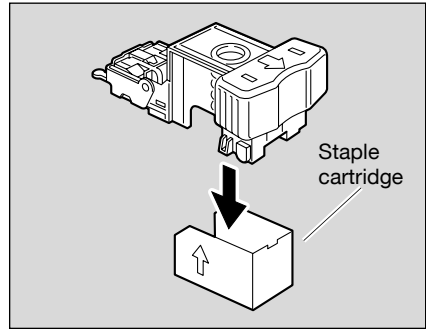

- 5 Load the new staple cartridge into the staple cartridge holder.
 - Fully insert the staple cartridge as far as possible.

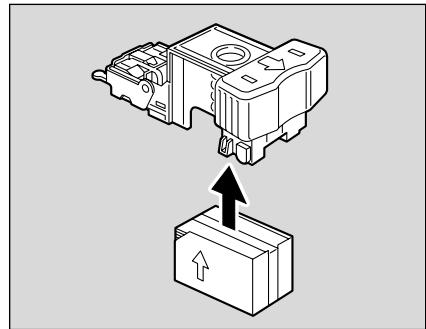

- 6 Peel the tape off of the staple cartridge.

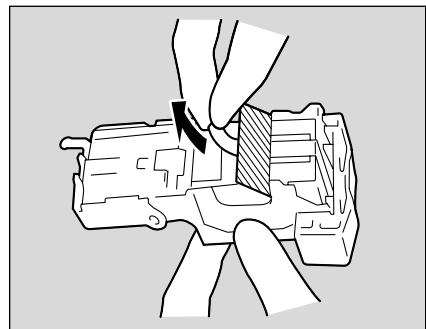

- 7 Insert the staple cartridge holder until it locks into place.

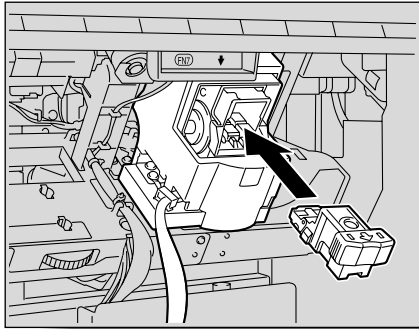

- 8 Slide the finisher back against the machine.



Reminder

Be sure to replace the staple cartridge only after the message appears, otherwise the machine may be damaged.

To replace the staple cartridge for finisher FS-603

- 1 Open the front door of the finisher.

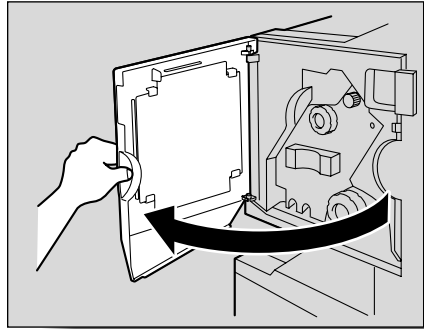

- 2 Turn misfeed-clearing dial 1 clockwise until the removal indicator is completely blue.

? What should be done if the misfeed-clearing dial 1 is turned too far?

- Turn the misfeed-clearing dial 1 counterclockwise to finely adjust it.

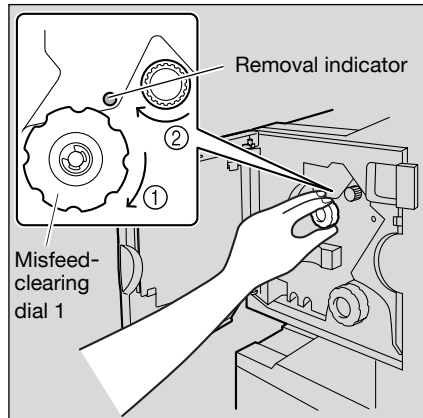

- 3 Slowly pull out the stapler unit as far as possible.

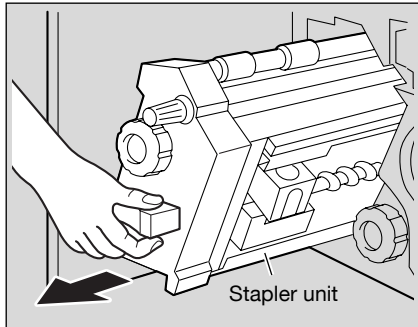

- 4 Grasp both sides of the staple cartridge holder, lift it up, and then pull it out.

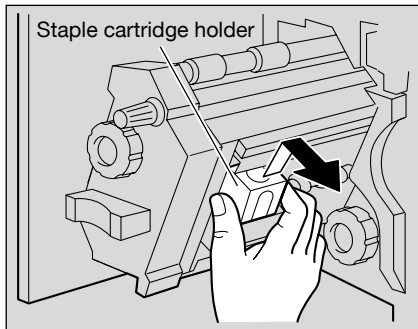

- 5 Press the button marked "PUSH" on the side of the staple cartridge holder. The staple case is released.

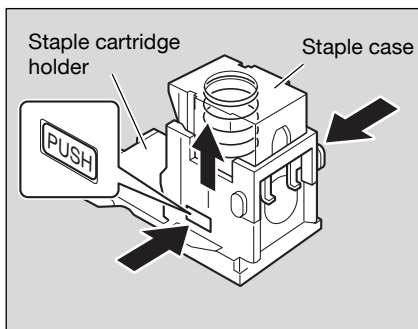

- 6 Pull up the staple case.

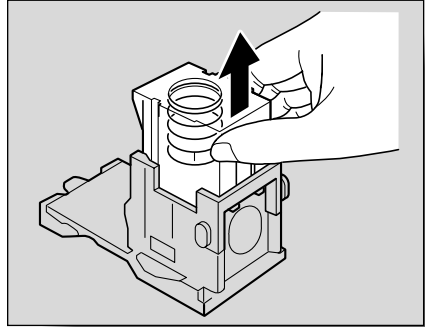

- 7 Remove the staple cartridge from the staple case.

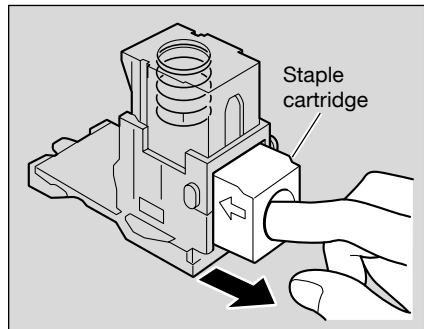

- 8 Load the new staple cartridge into the staple cartridge holder.
- Fully insert the staple cartridge as far as possible.

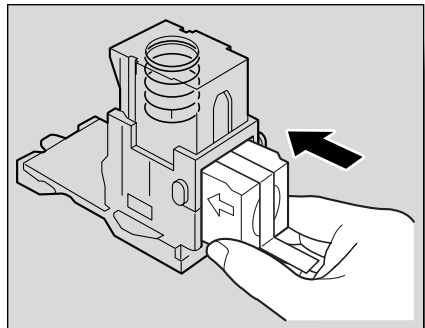

- 9 Press the staple case down.

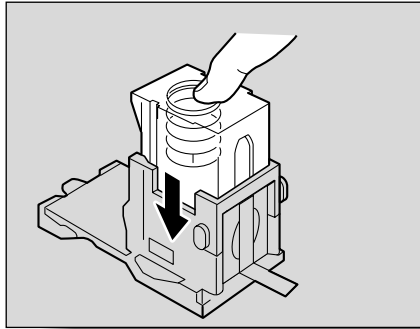

- 10 Peel the tape off of the staple cartridge.

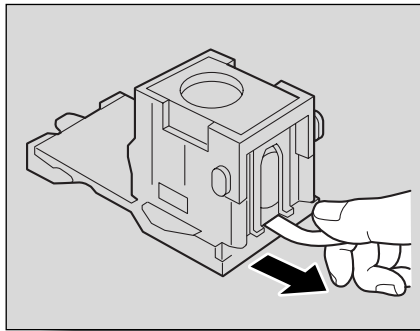

- 11 Insert the staple cartridge holder, making sure the tabs on the holder slide along the rails in the compartment.

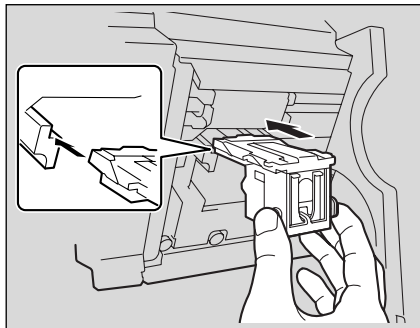

- 12** Insert the staple cartridge holder until it locks into place.
- Check that the staple cartridge holder is securely installed.

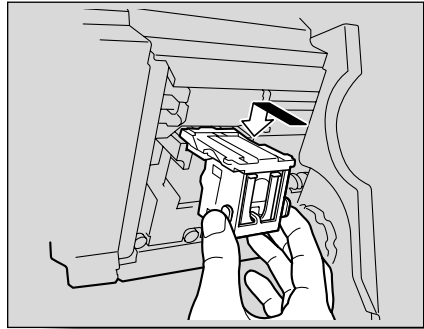

- 13** Carefully move the stapler unit back into its original position.
- 14** Close the front door.



Reminder

Be sure to replace the staple cartridge only after the message appears, otherwise the machine may be damaged.

9.3 Clearing a staple jam

If a staple jam occurs in the finisher, the message shown below appears.

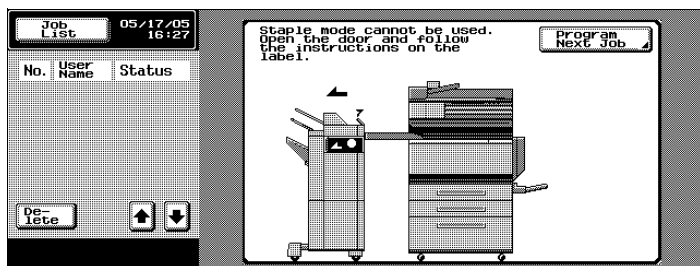
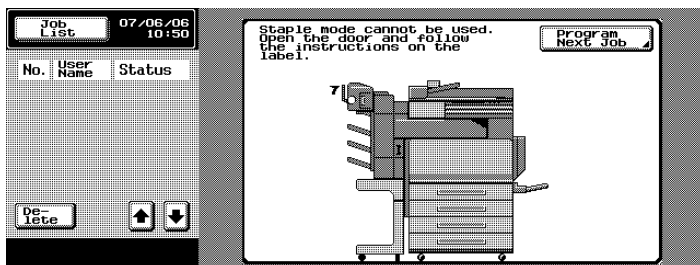
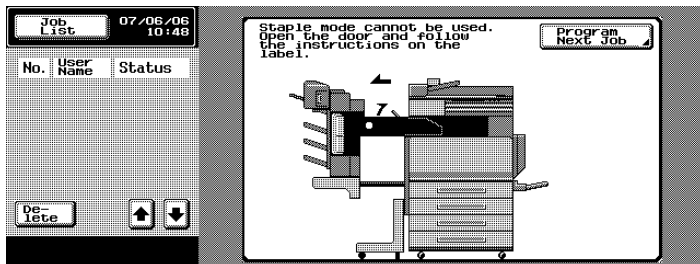

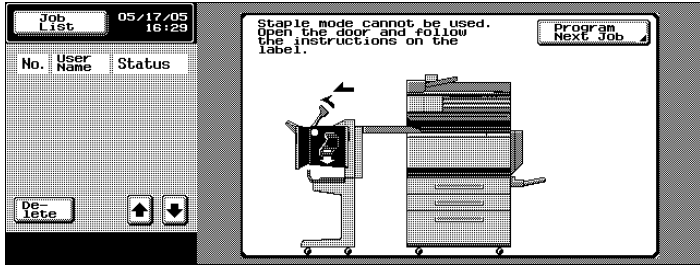

Reminder

Be careful when clearing jammed staples since injuries may result.

If the staples become jammed, follow the procedure described below. If the paper is pulled out with too much force, the stapler may be damaged.

To clear jammed staples in the finisher FS-514

- 1 Remove all paper from the finisher.

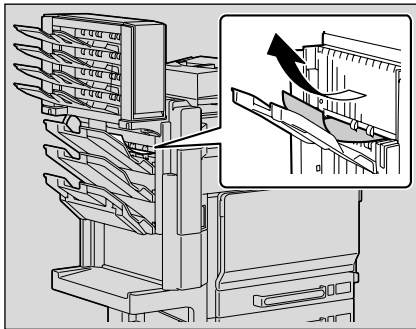

- 2 Open the front door.

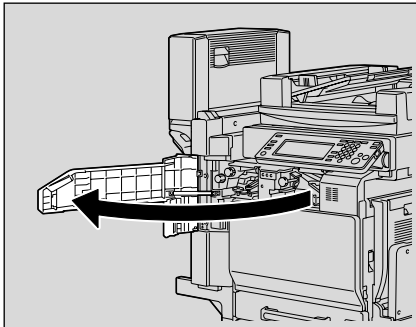

- 3 Raise lever FN1, turn lever FN2, and then pull out any paper.

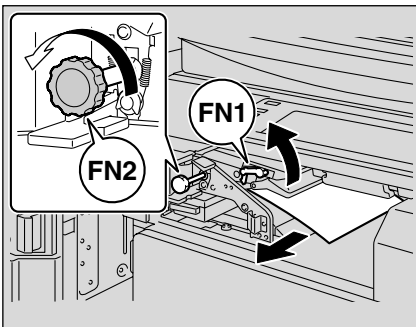

- 4 Lower guide FN3, and then pull out any paper.

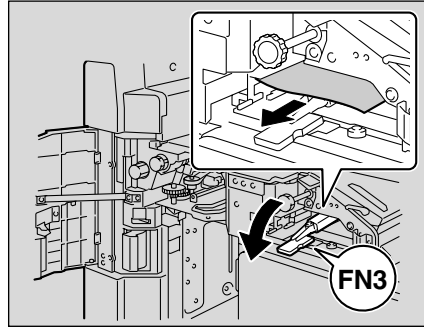

- If the punch kit is installed, pull out the hole-punch waste container FN3.1.

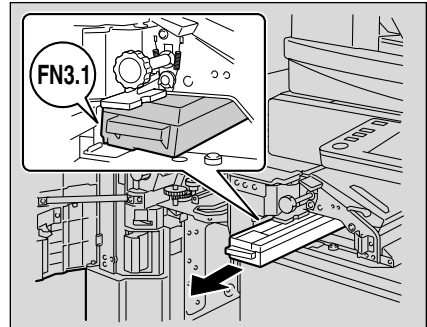

- 5 Return guide FN3 to its original position.

- If the punch kit is installed, insert hole-punch waste container FN3.1 in its original position.

- 6 Turn dial FN4 to feed the paper, open the transport unit cover, and then pull out any paper.

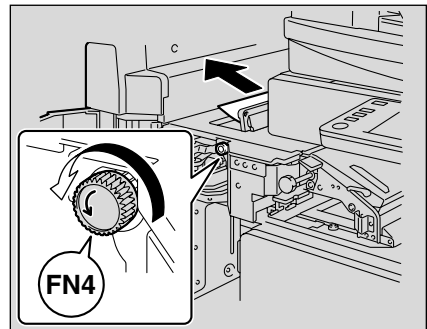

- 7 Turn dial FN5 or dial FN6, and then pull out any paper.

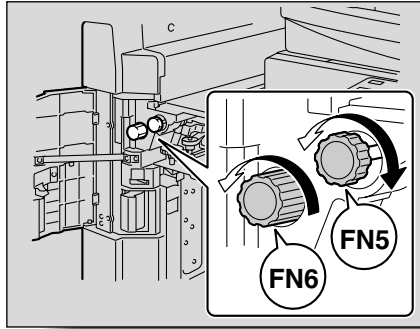

- 8 Turn the dial to the left to move the stapler toward the front.

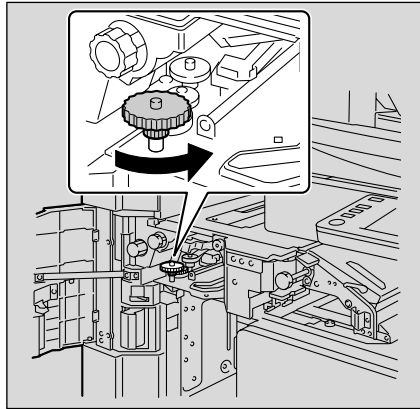

- 9** Remove the staple cartridge holder.
- Pull the staple cartridge holder toward you to remove it.
 - Only touch the blue parts of the staple cartridge.

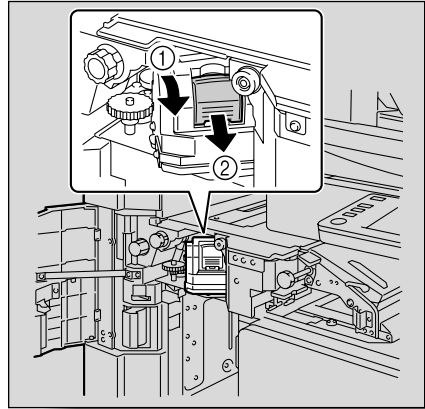

- 10** Swing open the shutter of the staple cartridge holder, and then pull out one sheet of staples.

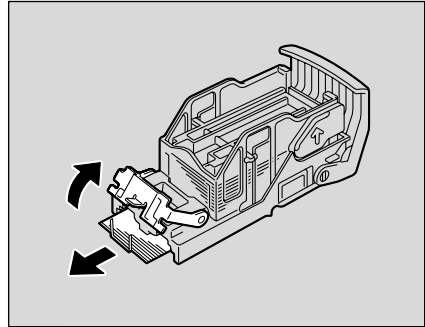

- 11** Return the shutter of the staple cartridge holder to its original position.

- 12 Insert the staple cartridge holder, making sure the tabs on the holder slide along the rails in the compartment.

- Check that the staple cartridge holder is securely installed.

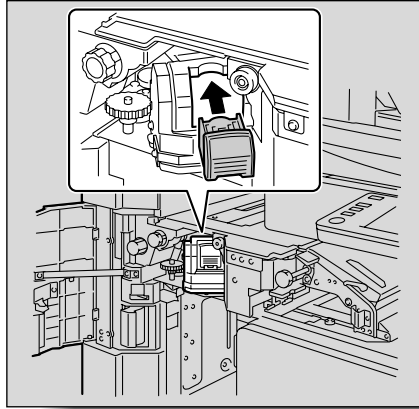

- 13 Close the front door.



Reminder

If stapling still cannot be resumed, even after performing the above procedure, contact your technical representative.

To clear jammed staples in the saddle sticher

- 1 Open the front door.

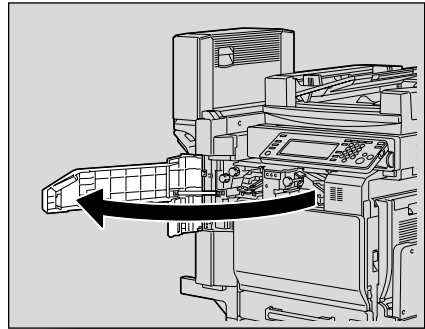

- 2 Raise lever FN1, turn lever FN2, and then pull out any paper.

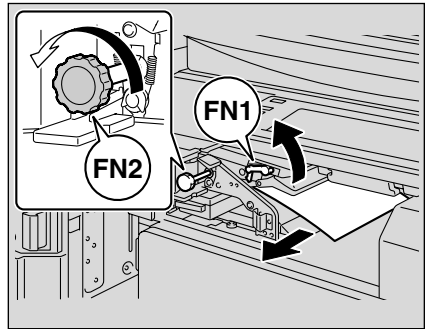

- 3 Lower guide FN3, and then pull out any paper.

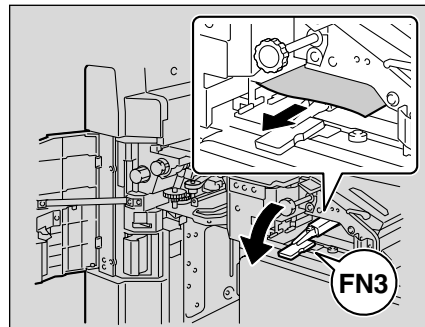

- If the punch kit is installed, pull out the hole-punch waste container FN3.1.

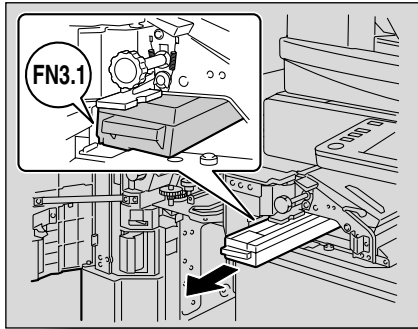

- 4 Return guide FN3 to its original position.
 - If the punch kit is installed, insert hole-punch waste container FN3.1 in its original position.

- 5 Turn dial FN4 to feed the paper, open the transport unit cover, and then pull out any paper.

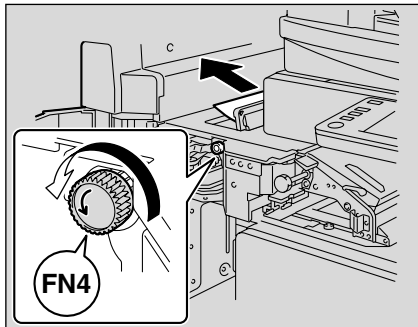

- 6 Turn dial FN5 or dial FN6, and then pull out any paper.

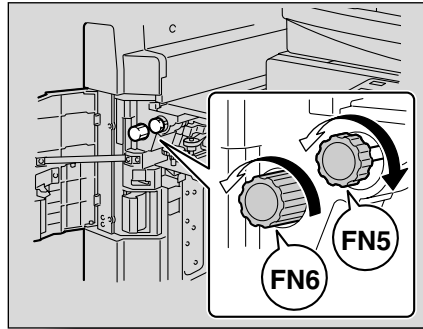

- 7 Open the misfeed-clearing door, and then pull out any paper.

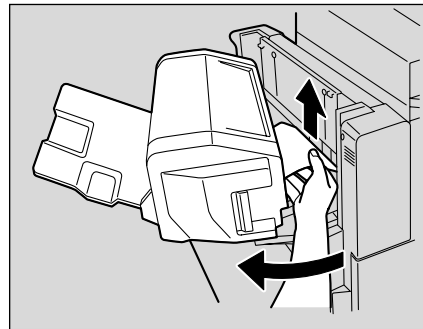

- 8 Close the misfeed-clearing door.

- 9 Raise the finishing tray, and then push down the staple cartridge holder and remove it.

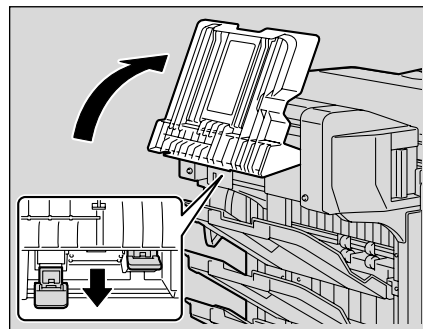

- 10** Swing open the shutter of the staple cartridge holder, and then pull out one sheet of staples.

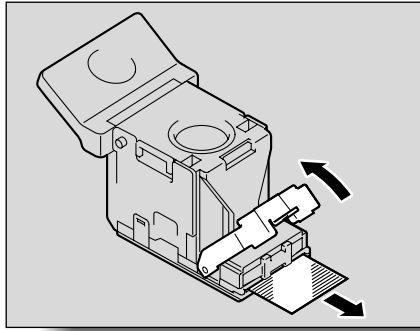

- 11** Return the shutter of the staple cartridge holder to its original position.

- 12** Insert the staple cartridge holder, and then push it down until it locks into place.

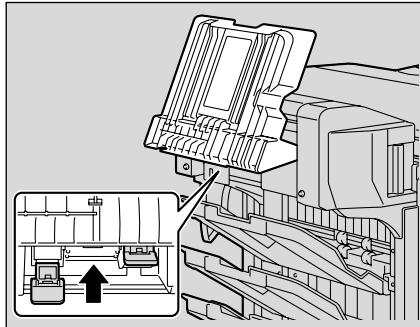

- 13** Return the copy output tray to its original position.

- 14** Close the front door.

To clear jammed staples in finisher FS-501

- 1 Slide the finisher away from the machine.

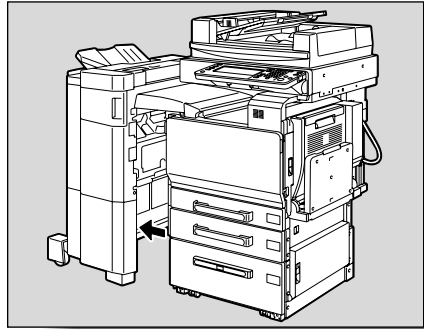

- 2 Turn the jammed-staple-clearing dial to the left in order to position stapler at the center.

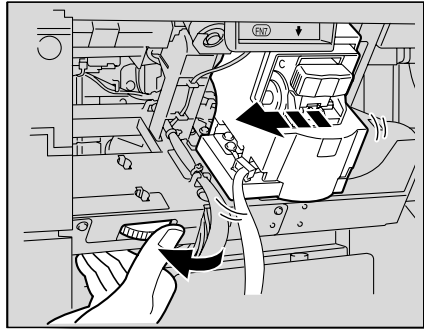

- 3 Pull the staple cartridge holder out toward you.

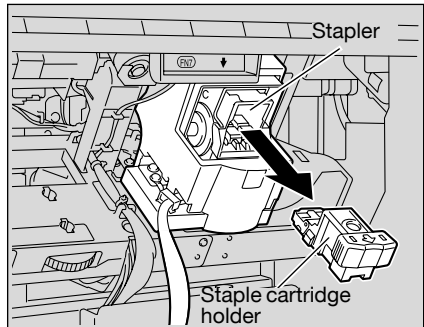

- 4 Swing open the shutter of the staple cartridge holder, and then pull out one sheet of staples.

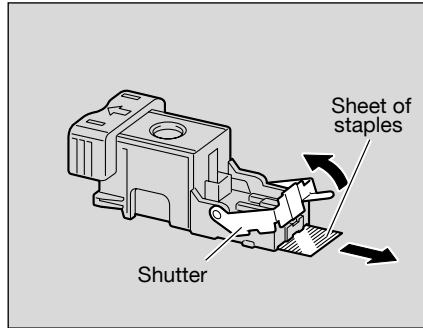

- 5 Return the shutter of the staple cartridge holder to its original position.
- 6 Insert the staple cartridge holder until it locks into place.

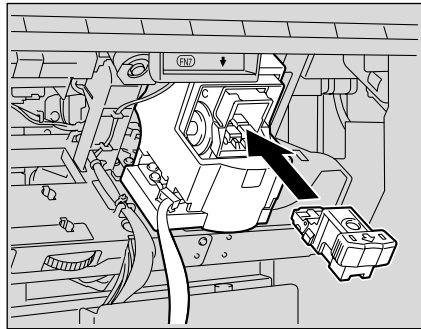

- 7 Slide the finisher back against the machine.

**Reminder**

If stapling still cannot be resumed, even after performing the above procedure, contact your technical representative.

To clear jammed staples in finisher FS-603

- ✓ If the message “Staple mode cannot be used.” appears, be sure to perform the following procedure.

If the following procedure is not followed and the paper is pulled out with too much force, the stapler unit may be damaged.

- 1 Slide the finisher away from the machine.

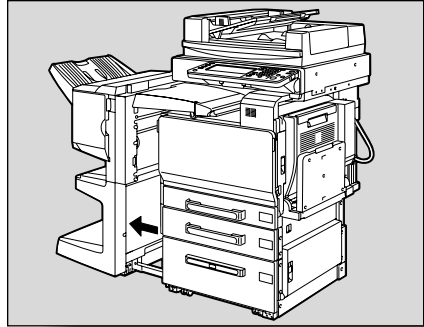

- 2 Open the horizontal transport unit cover, and then remove any misfed paper.

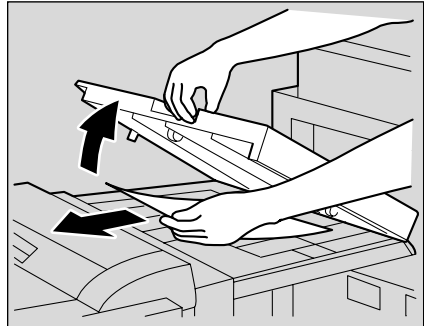

- 3 Close the horizontal transport unit cover.

- 4 Open the misfeed-clearing guide for the finisher, and then remove any misfed paper.

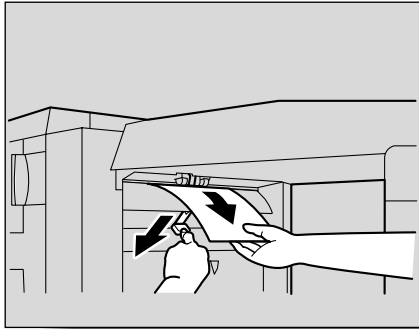

- 5 Open the front door of the finisher.

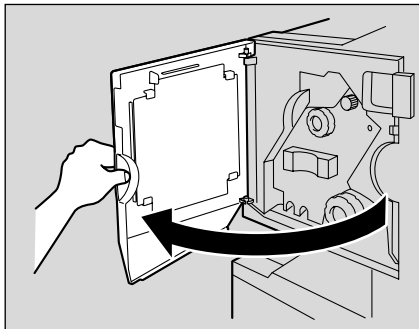

- 6 Turn misfeed-clearing dial 1 clockwise until the removal indicator is completely blue.

? If the misfeed-clearing dial 1 is turned too far

→ Turn the misfeed-clearing dial 1 counterclockwise to finely adjust it.

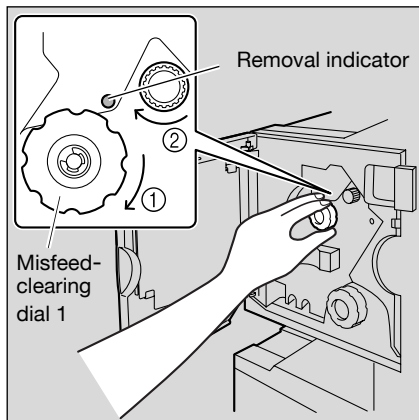

- 7 Remove all paper fed into the exit tray 1.

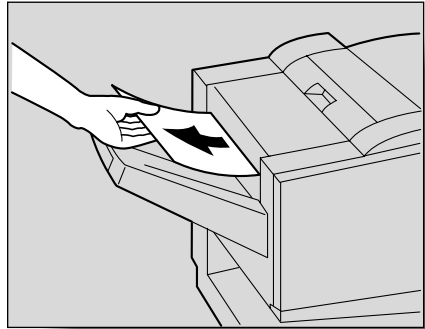

- 8 Open the Right-side door, and then pull out any misfed paper in the transport section.

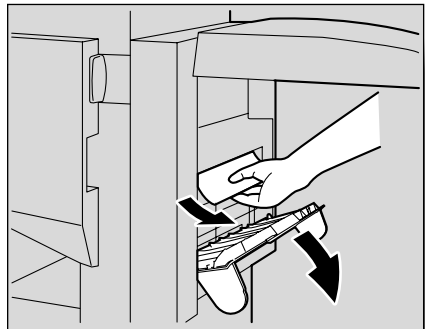

- 9 Clockwise turn the misfeed-clearing dial in the folding section. Feed out into the exit tray 2 the paper that could not be fed out in step 8, and then pull out the paper.

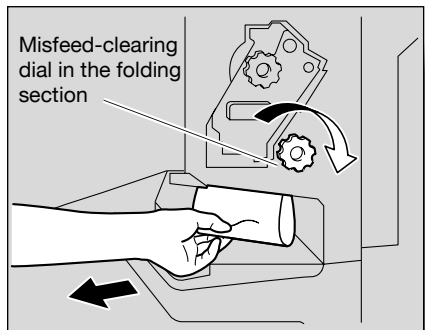

- 10 Slowly pull out the stapler unit as far as possible.

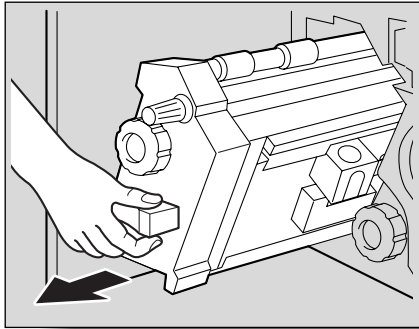

- 11 Turn misfeed-clearing dial 2 clockwise until the cartridge removal indicators are aligned. The staple cartridge moves to a position from where it can be removed.

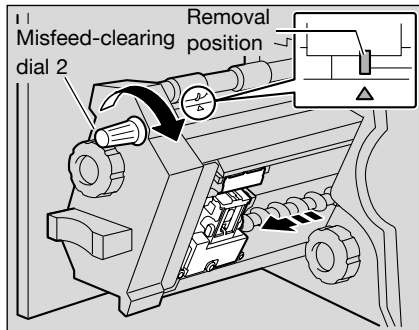

? What should be done if the misfeed-clearing dial 2 is turned too far?

- Turn the misfeed-clearing dial 2 counterclockwise to adjust it so the cartridge removal indicators are aligned.

- 12 Grasp both sides of the staple cartridge holder, lift it up, and then pull it out.

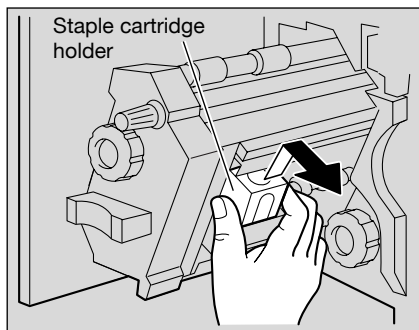

- 13** Swing open the shutter of the staple cartridge.

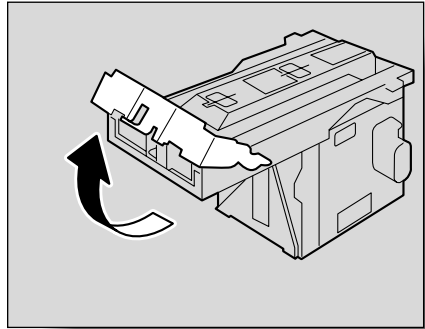

- 14** Pull out toward you the two staples jammed at the end of the staple cartridge.

? What happens if both staples are not removed?

→ Stapling cannot continue correctly.

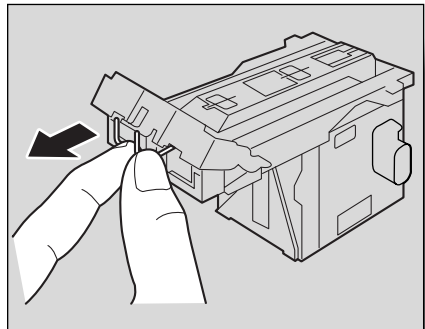

- 15** Return the shutter of the staple cartridge to its original position.

- 16** Insert the staple cartridge holder, making sure the tabs on the holder slide along the rails in the compartment.

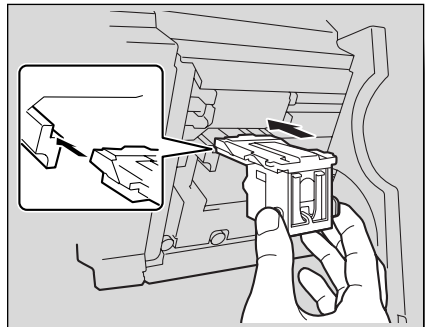

- 17** Insert the staple cartridge holder until it locks into place.
- Check that the staple cartridge holder is securely installed.

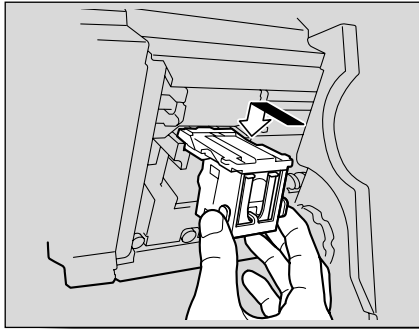

- 18** Carefully move the stapler unit back into its original position.

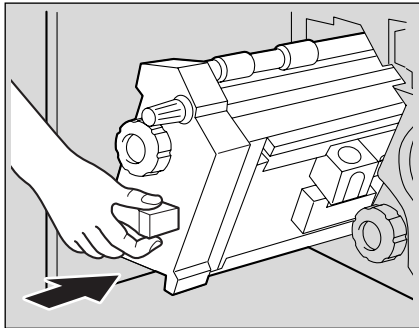

- 19** Close the front door.
- 20** Slide the finisher back against the machine.



Reminder

Do not pull out paper with too much force, otherwise the folding unit may be damaged.

9.4 Emptying the waste containers

If the hole-punch waste container in punch kit installed on finisher becomes full, the message shown below appears (if it can be emptied by the user).



Note

The setting for emptying the hole-punch waste container should be specified by the technical representative. For details, contact the technical representative.

The default setting is "Service". If a message appears, immediately contact the technical representative.

Display for the Punch Dust Box setting

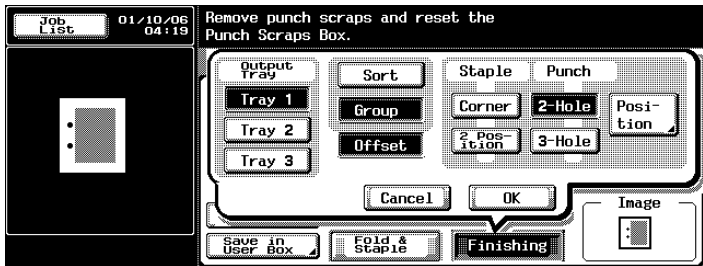
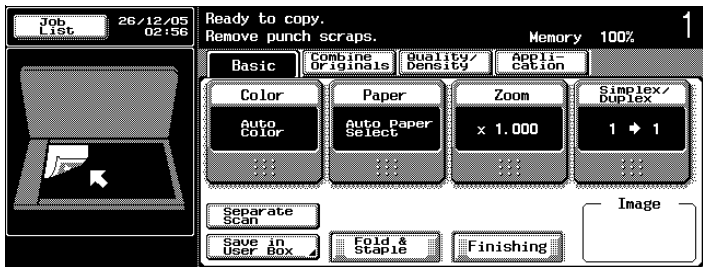

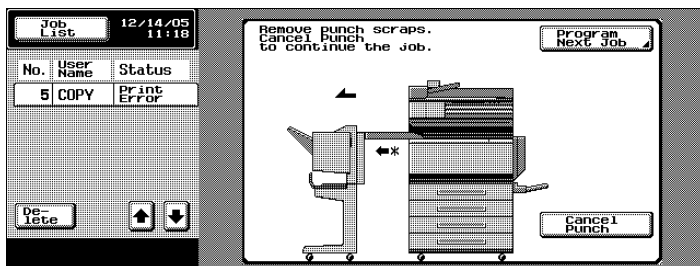
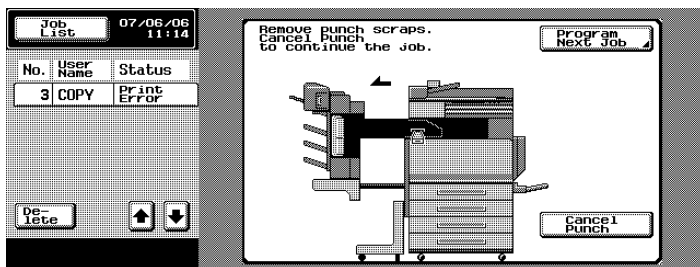
Display while a job is being performed**Detail**

When performed by user

If the hole-punch waste container has become full while a job is being performed, the job being performed is paused. To continue the job without canceling the Punch setting, empty the hole-punch waste container. To cancel the Punch setting and continue the job, touch [Cancel Punch].

When performed by technical representative

If the hole-punch waste container has become full while a job is being performed, the job being performed is paused. To continue the job, touch [Cancel Punch]. However, the continued job is printed without holes being punched.

Display in Enlarge Display mode

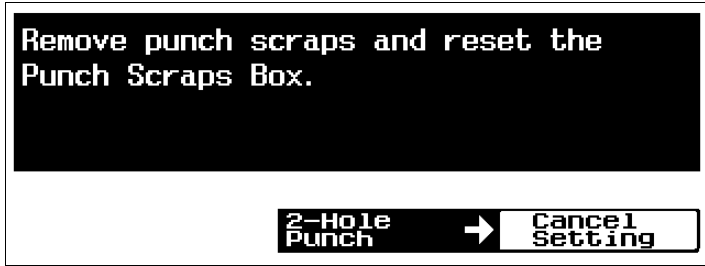

To empty the hole-punch waste container for finisher FS-514

Follow the procedure described below to empty the hole-punch waste container.

- 1 Open the front door.

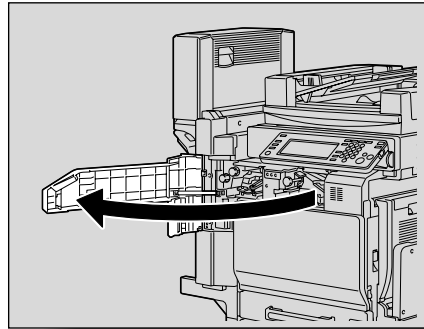

- 2 Pull out the hole-punch waste container FN3.1.

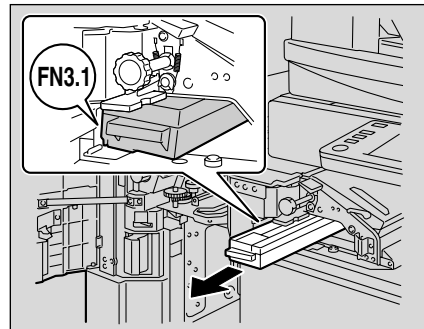

- 3 Empty the hole-punch waste container.

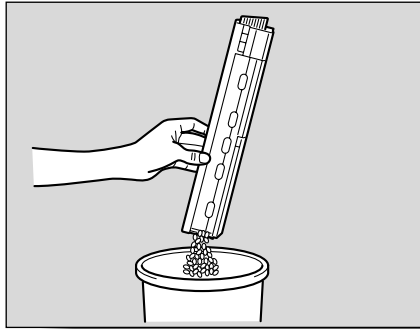

- 4 Insert the hole-punch waste container at its original position.
- 5 Close the front door.

To empty the hole-punch waste container for finisher FS-603

Follow the procedure described below to empty the hole-punch waste container.

- 1 Slide the finisher away from the machine.

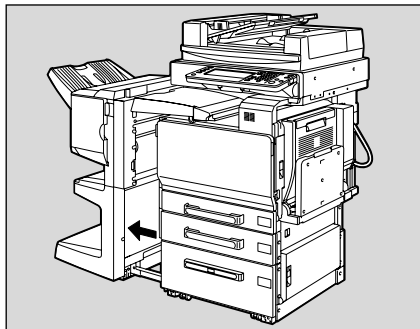

- 2 Pull out the hole-punch waste container.

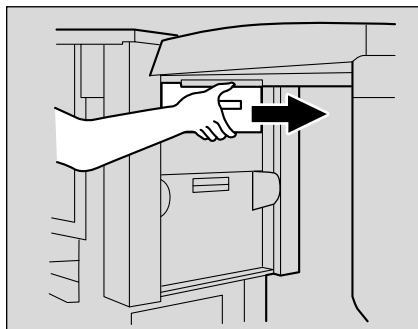

- 3 Empty the hole-punch waste container.

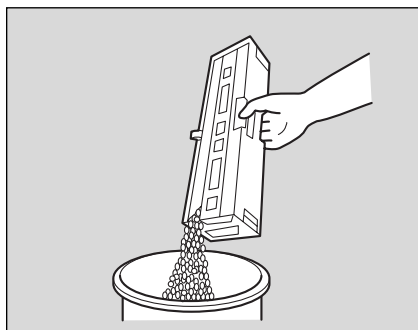

- 4 Install the hole-punch waste container into its original position.
- 5 Slide the finisher back against the machine.

9.5 Replacing the waste toner box

When it is almost time to replace the waste toner box (and if it is replaceable by the user), the message shown in the following illustration appears, warning about the replacement period.

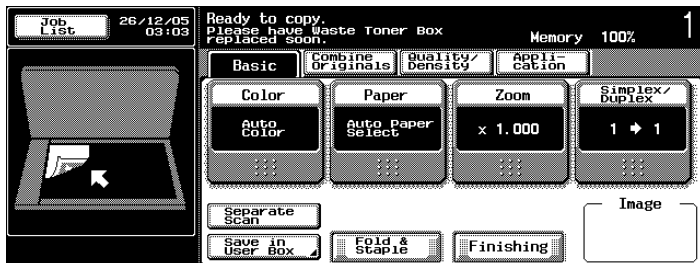

Reminder

When the message appears, replace the specified supplies or part according to your maintenance agreement.



Detail

The number of copies that can be made from the time that the message "Please have Waste Toner Box replaced soon." appears until the time that the message "Waste Toner Box needs replacing. Follow the Replacing Instruction." appears differs depending on the specified copy settings and the part/supplies.

When it is time to replace the waste toner box (and if it is replaceable by the user), the message "Waste Toner Box needs replacing. Follow the Replacing Instruction." appears and the machine stops operating.

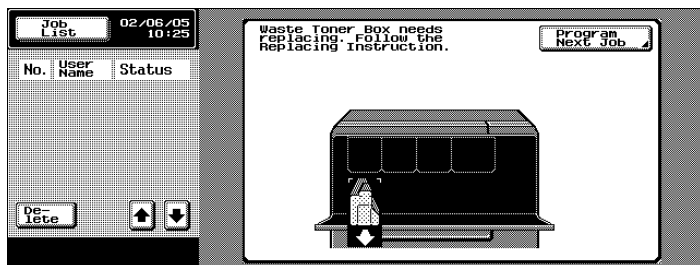

Display in Enlarge Display mode

When the time to replace the part is reached, the following screen appears.

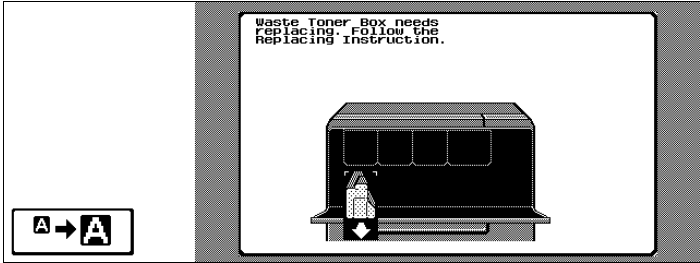

Touch  to display the message shown below.

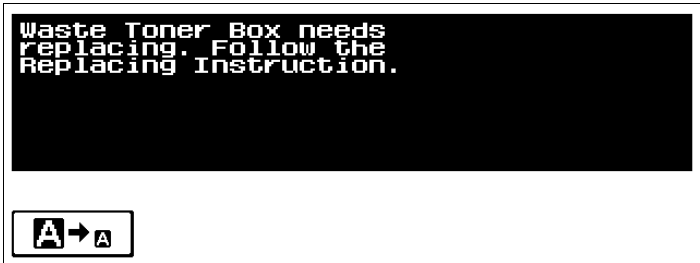

To replace the waste toner box

Follow the procedure described below to replace the waste toner box.

- 1 Open the machine's front door.

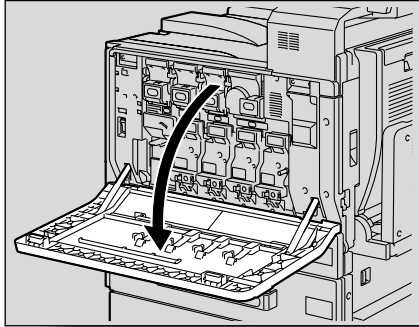

- 2 Pull the waste toner release lever.

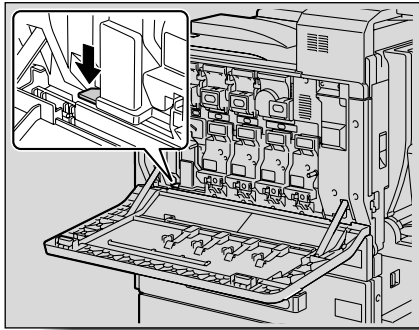

- 3 Remove the waste toner box.

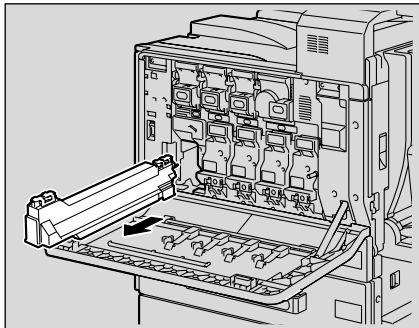

- 4 Install the new waste toner box.

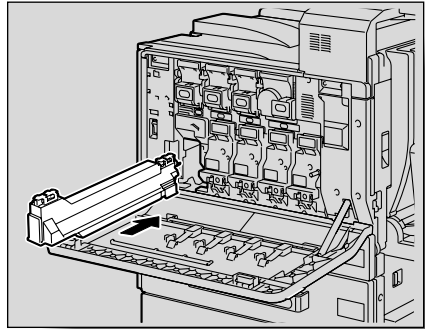

- 5 Remove filter 1, and then install the new filter 1.

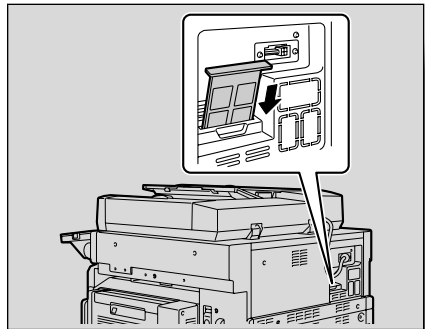

- 6 Close the front door.

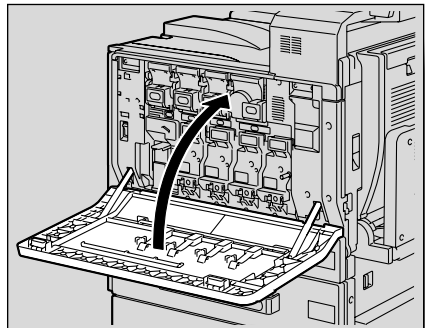

 **CAUTION****Handling toner and the toner cartridges**

- Do not throw toner or the waste toner box into a fire.
 - Toner expelled from the fire may cause burns.
-

 **CAUTION****Precautions for toner spills**

- Be careful not to spill toner inside the machine or get toner on your clothes or hands.
 - If your hands become soiled with toner, immediately wash them with soap and water.
 - If toner gets in your eyes, immediately flush them with water, and then seek professional medical attention.
-

**Reminder**

Do not tilt the removed waste toner box, otherwise waste toner may spill.

Do not throw away used waste toner boxes. Instead, keep them in their boxes to be collected by your technical representative.

10

Care of the machine

10 Care of the machine

10.1 Cleaning

This section describes the procedures for cleaning each part.

Housing

- 1 Clean the surface of the housing by wiping it with a soft cloth dampened with a mild household detergent.

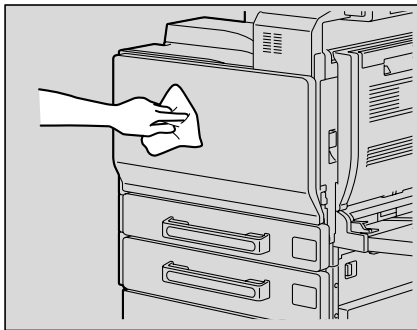

Reminder

Be sure to turn off the machine (set the power switch to "O") before cleaning it.

Never use solvents, such as benzene or thinner, to clean the housing.

Original glass

- Clean the surface of the original glass by wiping it with a soft, dry cloth.

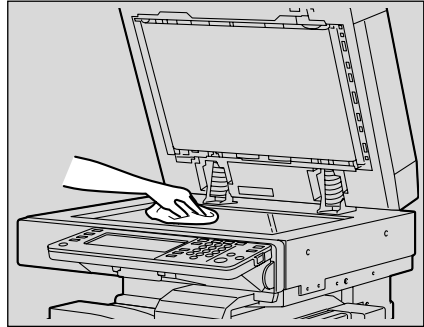
**Reminder**

Never use solvents, such as benzene or thinner, to clean the original glass.

Control panel

- Clean the control panel by wiping it with a soft, dry cloth.

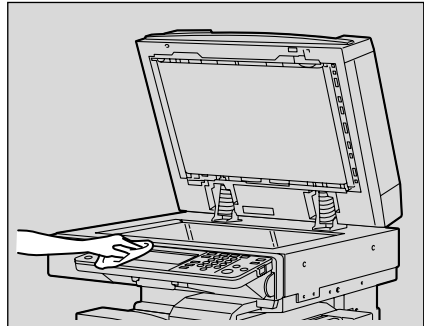
**Reminder**

Pressing too hard on the control panel or the touch panel may damage them. In addition, never use a mild household detergent, glass cleaner, benzene or thinner to clean the control panel or touch panel.

Document transfer belt

- 1 Clean the document transfer belt by wiping it with a soft cloth dampened with a mild household detergent.

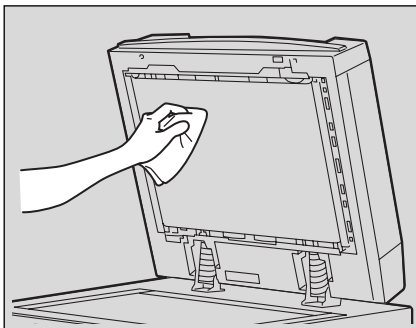

- 2 Carefully slide the belt to the left to expose a hidden area of the belt.

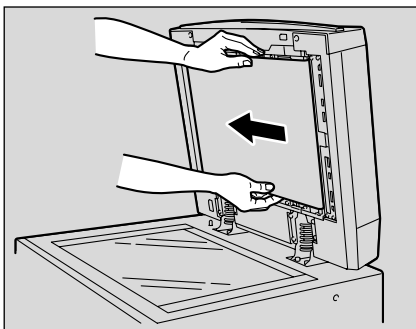

- 3 Clean the newly exposed surface of the belt by wiping it with a soft cloth dampened with a mild household detergent (as in step 1). Repeat the above step until the entire surface of the document transfer belt has been wiped clean.



Reminder

Never use solvents, such as benzene or thinner, to clean the document transfer belt.

Original cover pad

- Clean the surface of the pad by wiping it with a soft cloth dampened with a mild household detergent.

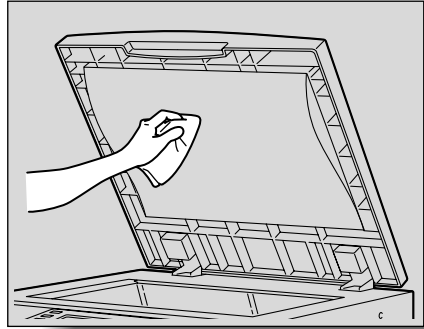
**Reminder**

Never use solvents, such as benzene or thinner, to clean the original cover pad.

Paper Take-Up roller

- Clean the paper take-up rollers by wiping them with a soft, dry cloth.

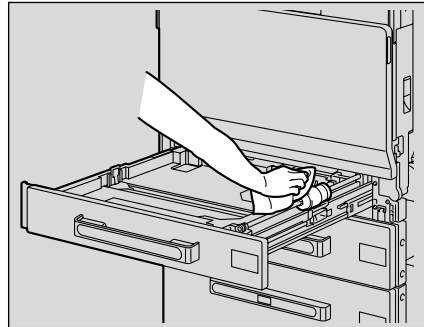
**Reminder**

Never use solvents, such as benzene or thinner, to clean the paper take-up roller.

Electrostatic charger wire

If the electrostatic charger wire is dirty, streaks will appear though the printed images. If this occurs, follow the procedure described below to clean the electrostatic charger wire.

- 1 Open the machine's front door.
- 2 Slowly pull out the charger-cleaning tool as far as possible. Next, slowly push in the charger-cleaning tool as much as possible. Repeat the above operations three times.

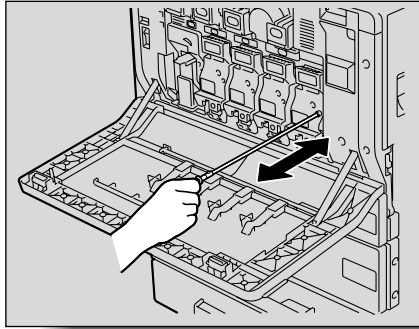

- 3 Securely insert each charger-cleaning tool, and then close the front door.

Print head

If the print head becomes dirty, decreased print quality may result. If this occurs, clean the print head according to the following procedure.

- 1 Open the machine's front door.
- 2 Remove the cleaning tool from the machine's front door.

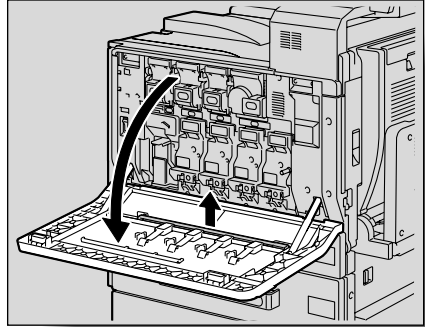

- 3 Insert the cleaning tool into the print head cleaning opening, pull it out, and then repeat this back and forth movement two or three times.

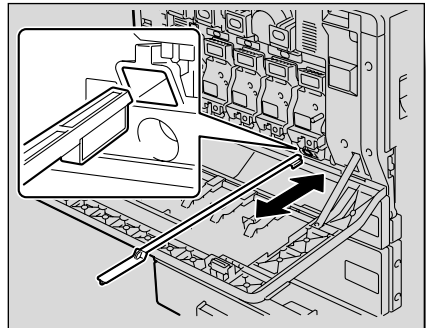

10.2 Viewing counters (Meter Count)

Viewing counters

The Meter Count screen can be displayed so that the total number of prints since counting started can be viewed.

In addition, the list of counters can be printed.

To view the counters

- 1 Press the [Utility/Counter] key.
- 2 Touch [Details] in the sub display area.

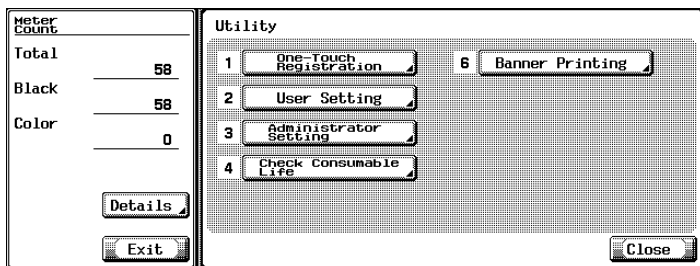

The list of counters appears.

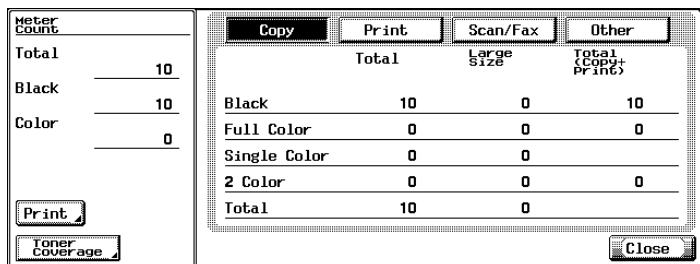

? Can the list of counters be printed?

→ Touch [Print], select the paper size, and then press the [Start] key.

- Touch [Close], and then touch [Close] in the next screen that appears. The Basic screen appears again.



Note

The list of counters can be displayed even while the machine is copying or printing.

Viewing the coverage rate

The amount of toner that was used can be viewed in the Toner Coverage screen.

To view the coverage rate

- Press the [Utility/Counter] key.
- Touch [Details] in the sub display area.

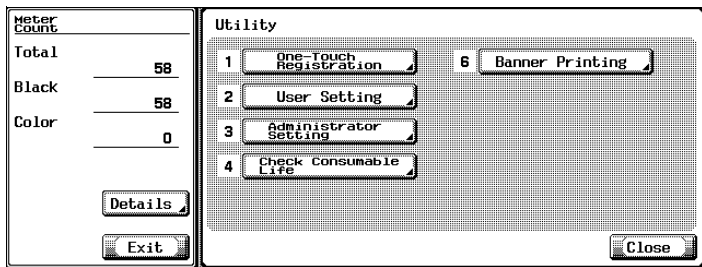

The list of counters appears.

- Touch [Toner Coverage].

Toner Coverage					
	%	Copy	Print	Scan/Fax	Total
Color	Cyan	0.000	0.000	0.000	0.000
	Magenta	0.000	0.000	0.000	0.000
	Yellow	0.000	0.000	0.000	0.000
	Black	0.000	0.000	0.000	0.000
Black		0.000	0.000	0.000	0.000

Buttons: Meter Count (bottom left), Close (bottom right)

- Touch [Close], and then touch [Close] in the next screen that appears. The Basic screen appears again.

10.3 When the message “Preventive maintenance time.” appears

If the message “Preventive maintenance time.” appears, contact your technical representative and request a periodic maintenance inspection.

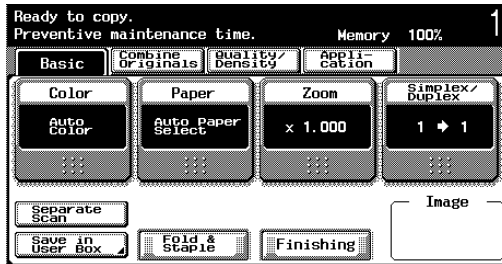

11

Managing jobs (Job List)

11 Managing jobs (Job List)

11.1 Overview of the Job List screen

Jobs

Specifying the desired copy settings, then pressing the [Start] key queues the copy operation in this machine. This queued operation is called a job. In the same way, operations for making scans and computer printouts are also queued as jobs.

- Jobs that are being performed and the job log can be checked from the Job List screen.
- Jobs are printed starting with the one at the top of the Current Jobs list.
- Jobs are numbered in the order that they were programmed and are queued to be performed (printed).



Note

The job number identifies the job; it does not indicate the printing order. In addition, the job number does not change until the job is deleted.

By using the "Increase Priority" function, the selected job can be moved to the front of the queue so that it is printed first.

Multi-Job feature

Queued jobs are managed by the machine.

- While one job is being printed, another job can be queued. A total of 251 jobs can be queued.
- The number of jobs possible for each function is listed below. (The values listed below are for reference and may differ from the actual values depending on other settings.)
 - Copy mode: 5
 - Interrupt mode: 1
 - Scan mode: 5
 - TWAIN (Push, Pull): 1
 - Printing: 10
 - Faxes (Quick transmissions): 1
 - Faxes (Memory transmissions): 50
 - Faxes (Timer TX): 20
 - Received faxes: 100
 - Faxes (Polling RX): 1
 - Faxes (Polling TX): 1
 - Shared: 56

- Total: 251
- When one job is finished being printed, the next queued print job automatically begins.



...

Note

Up to 251 jobs, including print jobs, scanner transmission jobs, fax transmission jobs and received fax/saved jobs, can be queued.

Job list screens

An overview of the Job List screens is provided below.

- From the Job List screen, the following tabs for various specific functions can be displayed.
 - Print:
Lists print jobs for copying, computer printing, and received faxes
 - Scan:
Lists scanner transmission jobs
 - Fax TX:
Lists fax transmission jobs
 - RX/User Box:
Lists received fax jobs and print jobs saved in boxes



...

Note

As the factory default, “Job List Default” is set to “Current Print Jobs”. For details on changing the default display for the Job List screen, refer to “Display setting” on page 12-19.



The screen for each function listed above can be displayed from any other Job List screen. However, if the screen is changed while a setting is being changed, that setting is canceled.

- A Current Jobs list and a Job History list can be displayed for each function.
 - Current Jobs:
Lists jobs that are queued and being performed, allowing you to check the current status of the machine
 - Job History:
Lists jobs that have been completed, including jobs that were not performed due to an error, allowing you to check the history and results of all jobs
- The type of jobs to be displayed can be selected from the Current Jobs list and Job History list. For example, the lists of stored jobs and active jobs are displayed in the Current Jobs list on the Print tab, and the lists of deleted jobs, completed jobs and all jobs are displayed in the Job History list. The types of jobs that can be selected differ depending on the selected tab.

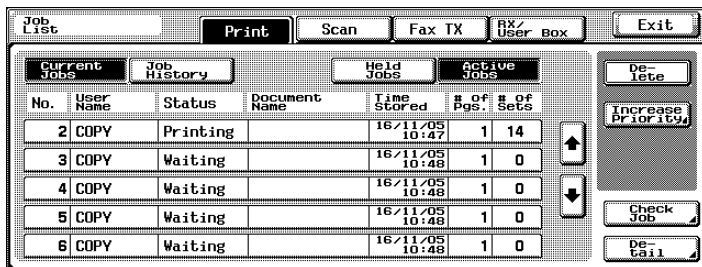
- The function of each button in the Job List screens is described below.



Name	Description
[Print]	A selected button indicates which job list is currently displayed.
[Scan]	Displays the Scan tab of the Job List screen For details, refer to the Network Scanner Operations of the User's Guide.
[Fax TX]	Displays the Fax TX tab of the Job List screen For details, refer to the Facsimile Operations and the Network Facsimile Operations of the User's Guide.
[RX/User Box]	Displays the RX/User Box tab of the Job List screen For details, refer to the Facsimile Operations and the Network Facsimile Operations of the User's Guide.
[Current Jobs]	Switches from Job History to Current Jobs This lists the jobs that are currently being performed and the jobs are queued (waiting) to be performed.
[Job History]	Switches from Current Jobs to Job History. This lists the completed jobs.
[Held Jobs] [Active Jobs] (displayed on the Current Jobs list of the Print tab)	Specifies the type of jobs displayed in the Job List screen Change the display mode by touching the appropriate button. The buttons that appear differ depending on the tab or list (Current Jobs or Job History) that is displayed.
[Exit]	Quits Job List mode and returns to the screen that was displayed before [Job List] was touched
[Delete] ^{*1}	Deletes job selected in the Current Jobs list. For details, refer to "To delete a job" on page 11-6.
[Increase Priority] (displayed on the Current Jobs list of the Print tab)	Selects the next job to be printed after the current job is finished. For details, refer to "To increase priority for printing" on page 11-17. The buttons that appear differ depending on the tab or list (Current Jobs or Job History) that is displayed.
[Check Job] ^{*1}	Displays screens for checking the settings for the job selected in the Current Jobs list. For details, refer to "To check the job settings" on page 11-8.

Name	Description
[Detail]	Displays screens for checking the status, results, error details, user name, queued time, completed time and number of copies for jobs in the job lists. For details, refer to “Displayed information” on page 11-9.
[]/[] arrows	When there are more jobs than the five that can be displayed at one time, touch these arrows to display jobs higher or lower in the list (higher or lower in the printing order).

*1 Displayed when the Current Jobs list is displayed.

The following information is listed in the Print tab.

Item Name	Description
No.	Job identification number assigned when the job is queued
User Name	Displays the type (source) of the job. “COPY” is displayed for copy jobs.
Status (Current Jobs list only)	Displays the status of the job
Document Name	Displays the name of the file for print jobs sent from a computer If user authentication settings have been applied, the names of documents are not displayed for other users. The names of confidential documents are not displayed for other users.
Time Stored	Displays the time that the job was queued
# of Pgs.	Displays the number of pages in the original document
# of Sets	Displays the number of printed pages With jobs listed as “Printing” in the Current Jobs list, a count of the number of pages printed is displayed.
Result (Job History list only)	Displays the result of the operation (Job Complete, Error Cleared, Deleted by User, Mode cancelled from conflict)

11.2 Performing operations on jobs

To delete a job

A queued job or job being printed (job in the Active Jobs list) can be deleted.

- 1 In the Basic screen, touch [Job List].



The Job List screen appears.

- 2 In the Print tab, display the job to be deleted.
 - Jobs in the Job History list cannot be deleted.
- 3 Select the job to be deleted, and then touch [Delete].
 - If the job to be deleted is not displayed, touch [▲] and [▼] until the desired job is displayed.
 - If an incorrect job was selected, select a different job or touch the button for the selected job again to deselect it.

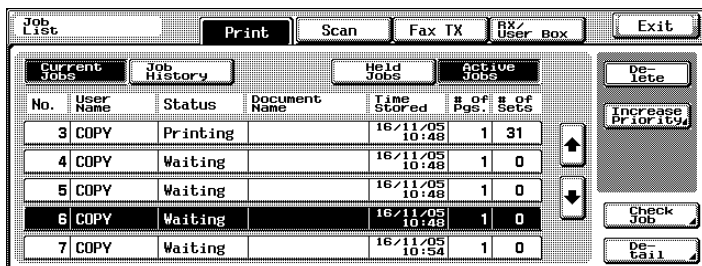

A message requesting confirmation to delete the job appears.

- 4 Check the information that is displayed, and then touch [Yes] if the correct job is indicated.
- To quit deleting the job, touch [No].



The screen displayed before [Delete] was touched appears again, and the job is deleted from the Current Jobs list.

- 5 Touch [Exit] or press the [Reset] key.

The screen that was displayed before [Job List] was touched appears again.



Note

If user authentication settings have been applied and the machine is set so that jobs cannot be deleted by other users, the job is not deleted.

To check the job settings

Job settings for stored jobs, jobs being printed, jobs queued to be printed and held jobs can be checked.

- 1 In the Basic screen, touch [Job List].
The Job List screen appears.
- 2 Display the list containing the job whose settings are to be checked.
- 3 Select the job whose settings are to be checked, and then touch [Check Job].
 - If an incorrect job was selected, select a different job or touch the button for the selected job again to deselect it.
 - The Mode Check screen appears.
 - The contents and number of Mode Check screens differ depending on the job that was selected.
 - The number to the left of [←Back] indicates the number of the currently displayed screen/the total number of screens.
 - To display the previous screen, touch [←Back]. To display the next screen, touch [Fwd.→].

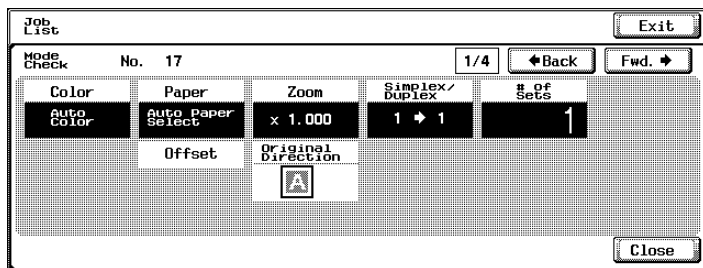

- 4 To finish checking the settings, touch [Close] or [Exit], or press the [Reset] key.
 - To return to the screen displayed before [Check Job] was touched, touch [Close].
 - To return to the Basic screen, touch [Exit] or press the [Reset] key.

Displayed information

The following information can be checked from the Job List screen.

- **Print tab**
Status (Receiving, Waiting, Printing, Printing Stopped, Print Error, Job Stored)^{*1}, Result (Job complete, Error cleared, Deleted by User, Deleted Due To Error)^{*2}, Error Detail^{*2}, Document Name, User Name, Start Time, End Time, # of pgs., # of Sets, Output Tray
- **Scan tab**
Status (Transferring, Dialing, Waiting)^{*1}, Result (Job complete, Error cleared, User Delete)^{*2}, Error Detail^{*2}, Address, Type, User Name, Time of Storage, End Time, # of pgs., File Name, No. of Dest (number of jobs being sent/number of specified recipients)^{*3}
- **Fax TX tab**
Status (Transferring, Waiting, Dialing, Redial Waiting)^{*1}, Result (Job Complete, Error cleared, User Delete, Deleted Due To Error)^{*2}, Error Detail^{*2}, Address, Type, User Name, TX No., Time of Storage, Start Time^{*4}, End Time, TX Time, # of pgs., Page Sent (number of jobs being sent/number of specified recipients)^{*3}
- **RX/User Box tab**
Detailed Status of Queued Job, Status (Receiving, Dialing)^{*1}, Result (Job complete, Error cleared, User Delete, Deleted Due To Error)^{*2}, Error Detail^{*2}, RX User Box (box number/box name), User Name, Time Stored, # of pgs., # of Sets, Output Tray, File Name

^{*1}Displayed only for jobs in the Current Jobs list

^{*2}Displayed only for jobs in the Job History list

^{*3}Displayed only for Current Jobs transmitted to multiple recipients

^{*4}Displayed only for timer transmission jobs

To check the job details

- 1 In the Basic screen, touch [Job List].
The Job List screen appears.
- 2 Display the list containing the job whose details are to be checked.
- 3 Select the job whose details are to be checked, and then touch [Detail].
 - If an incorrect job was selected, select a different job or touch the button for the selected job again to deselect it.
 The Check Detail screen appears.

Job List		Exit	
Check Detail		No. 38	
Status	Printing		
File Name		Time Stored	03/12/2004 14:58
User Name	COPY	# Of Pgs.	1
		# Of Sets	16
		Output Tray	Main Tray
		Delete	
		Close	

- 4 After the desired information has been checked, touch [Close] or [Exit] or press the [Reset] key.
 - To return to the screen displayed before [Detail] was touched, touch [Close].
 - To return to the Basic screen, touch [Exit] or press the [Reset] key.



Detail

To delete a queued job or job being performed, touch [Delete] in the Check Detail screen.

If [Detail] appears in the Check Detail screen for a job selected from the Scan or Fax TX tab, detailed information is available on the multiple recipients that the data was sent to with broadcast transmission. To view the information, touch [Detail].

To display current jobs (held jobs and active jobs lists)

The lists of received print jobs for Copy mode and Fax mode and for computer printing is displayed.

- 1 In the Basic screen, touch [Job List].
The Job List screen appears.
- 2 Touch the button for the desired list.

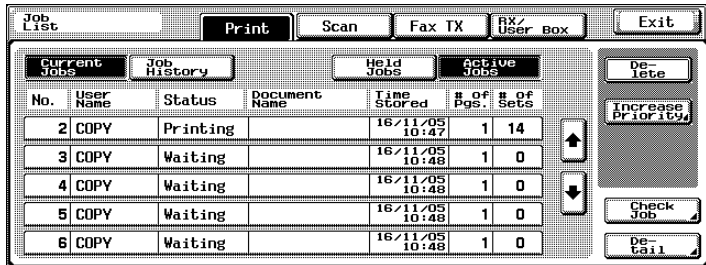

- Held Jobs: Displays only stored jobs
- Active Jobs: Displays only jobs that are being performed



Detail

For details on the function of each button, refer to "Job list screens" on page 11-3.

Proof copies of stored jobs can be printed. For details, refer to "To print a sample copy of a stored job" on page 11-13.

Stored jobs can be printed from the Release Held Job screen. For details, refer to "To print a stored job" on page 11-15.

To give priority for output to a job, touch [Increase Priority] in the Active Jobs list. For details, refer to "To increase priority for printing" on page 11-17.

To display Job History

- 1 In the Basic screen, touch [Job List].
The Job List screen appears.
- 2 Touch [Job History].
The Job History screen appears.
- 3 Touch the button for the desired list.

No.	User Name	Document Name	Time Stored	# of Pgs.	# of Sets	Result
4	COPY		16/11/05 10:48	1	99	Deleted by User
3	COPY		16/11/05 10:48	1	99	Job Complete
6	COPY		16/11/05 10:48	1	99	Deleted by User
2	COPY		16/11/05 10:47	1	99	Job Complete
1	COPY		16/11/05 10:10	1	1	Job Complete

- Deleted Jobs: Displays only jobs that were deleted before they were finished
- Finished Jobs: Displays only jobs that were correctly completed
- Active Jobs: Displays all jobs

To print a sample copy of a stored job

A single copy of a stored job can be printed in order to be checked.

The Held Jobs list contains jobs such as those for which a proof copy was being printed when the automatic system reset operation was performed and proof print jobs for data in the boxes.

- 1 Display the Held Jobs list in the Current Jobs list of the Print tab.
- 2 Touch [Release Held Job].

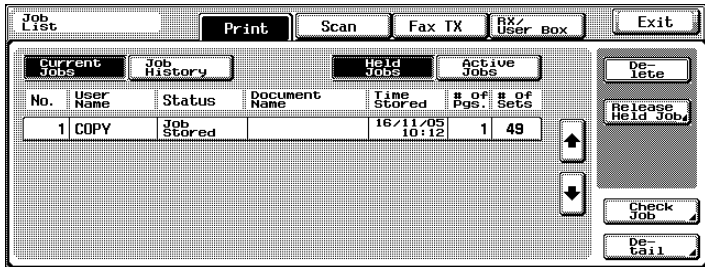

The Release Held Job screen appears.

- 3 From the job list, select the job whose sample copy is to be printed, and then touch [Proof Print].

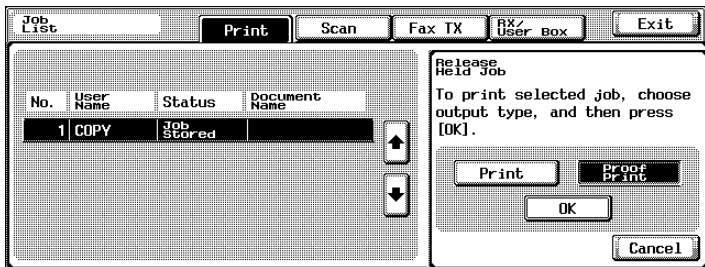

- If the job to be removed from the Held Jobs list is not displayed, touch [▲] and [▼] until the desired job is displayed.
- If an incorrect job was selected, touch the button for the selected job again to deselect it.

? How is the printing of a sample copy stopped?
 → Press the [Stop] key.

- 4 Touch [OK].
 - After the single sample copy is printed, check the print result.

**Detail**

To change the settings, touch [Change setting] in the Release Held Job screen. For details, refer to “To print a stored job” below.

To print a stored job

A job is removed from the Held Jobs list and printed.

- 1 Display the Held Jobs list in the Current Jobs list of the Print tab.
- 2 Touch [Release Held Job].

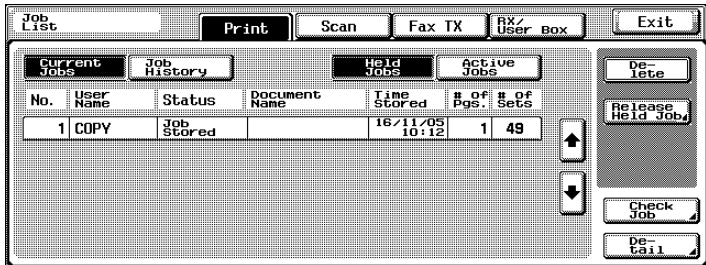

The Release Held Job screen appears.

- 3 Select the job to be removed from the Held Jobs list.

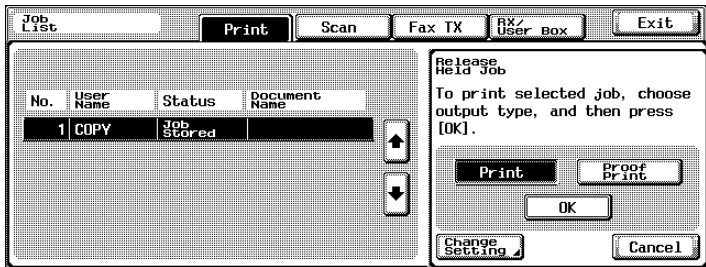

- If the job to be removed from the Held Jobs list is not displayed, touch [▲] and [▼] until the desired job is displayed.
- If an incorrect job was selected, select a different job or touch the button for the selected job again to deselect it.
- To continue without changing the specified copy settings, skip to step 6.

- 4 Touch [Change Setting].
 - To display [Change Setting], touch [Print].
 The Change Setting screen appears.

- 5 In the Change Setting screen, change the copy settings as desired, and then touch [OK].
- To cancel changes to the settings, touch [Cancel].

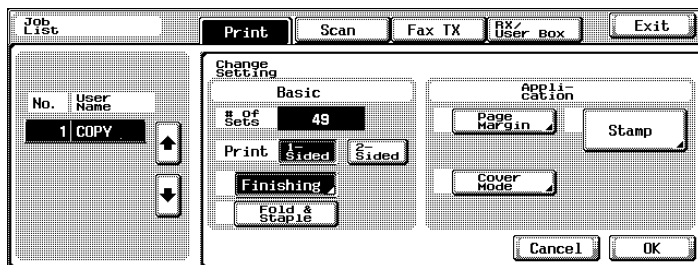

- ? Is there more information about the settings?
 → Refer to the appropriate section.

- 6 In the Release Held Job screen, touch [OK].

The stored job appears in the Active Jobs list and is printed.

- ? Can a sample copy be printed?
 → For details on printing a sample copy, refer to “To print a sample copy of a stored job” on page 11-13.
- ? How is the removal of a job from the Held Jobs list stopped?
 → Touch [Cancel].

To increase priority for printing

The next job to be printed after the current job being printed can be selected.

If an Administrator mode function was set so that the output priority of jobs cannot be changed, [Increase Priority] does not appear and the output priority of the jobs cannot be specified.

If the job currently being printed can be interrupted, printing is interrupted and printing of the job given priority begins. Printing of the interrupted job is automatically restarted once printing for the job given priority is finished.

If the job currently being printed cannot be interrupted (a job has already been interrupted or a job was already given priority), printing is interrupted after printing for the current job is finished.

- 1 Display the Active Jobs list in the Current Jobs list of the Print tab.
- 2 Touch [Increase Priority].

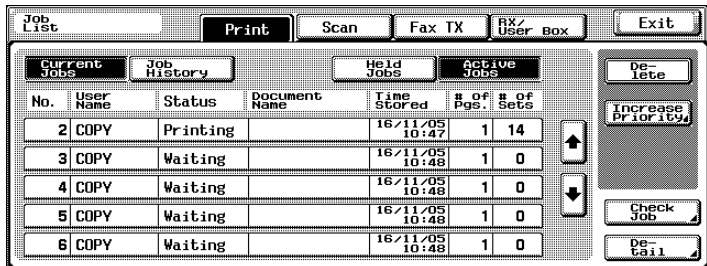

The Increase Priority screen appears.

- 3 In the job list, touch the button for the job to be given priority to select it, and then touch [OK].

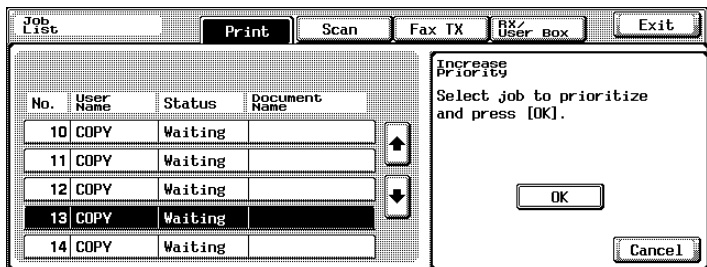

- If the job to be given priority is not displayed, touch [▲] and [▼] until the desired job is displayed.
- If an incorrect job was selected, select a different job or touch the button for the selected job again to deselect it.

The selected job moves to the top of the list and printing of the job begins.

? How is the changing of the output priority stopped?

→ Touch [Cancel].

12

Utility

12 Utility

12.1 Overview of utility mode parameters

List of registration information and parameters

This section describes the buttons available when the [Utility/Counter] key is pressed.



Note

The buttons that appear in the screens differ depending on the specified settings.

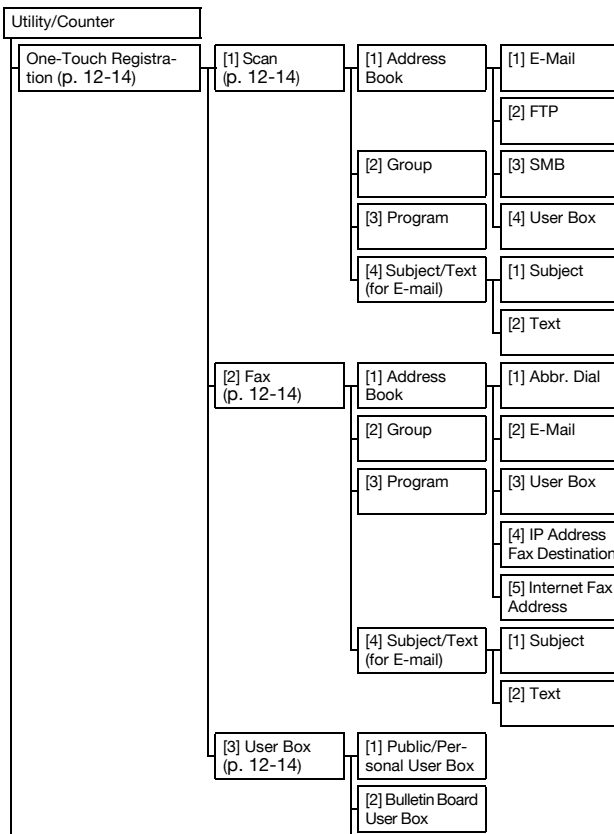

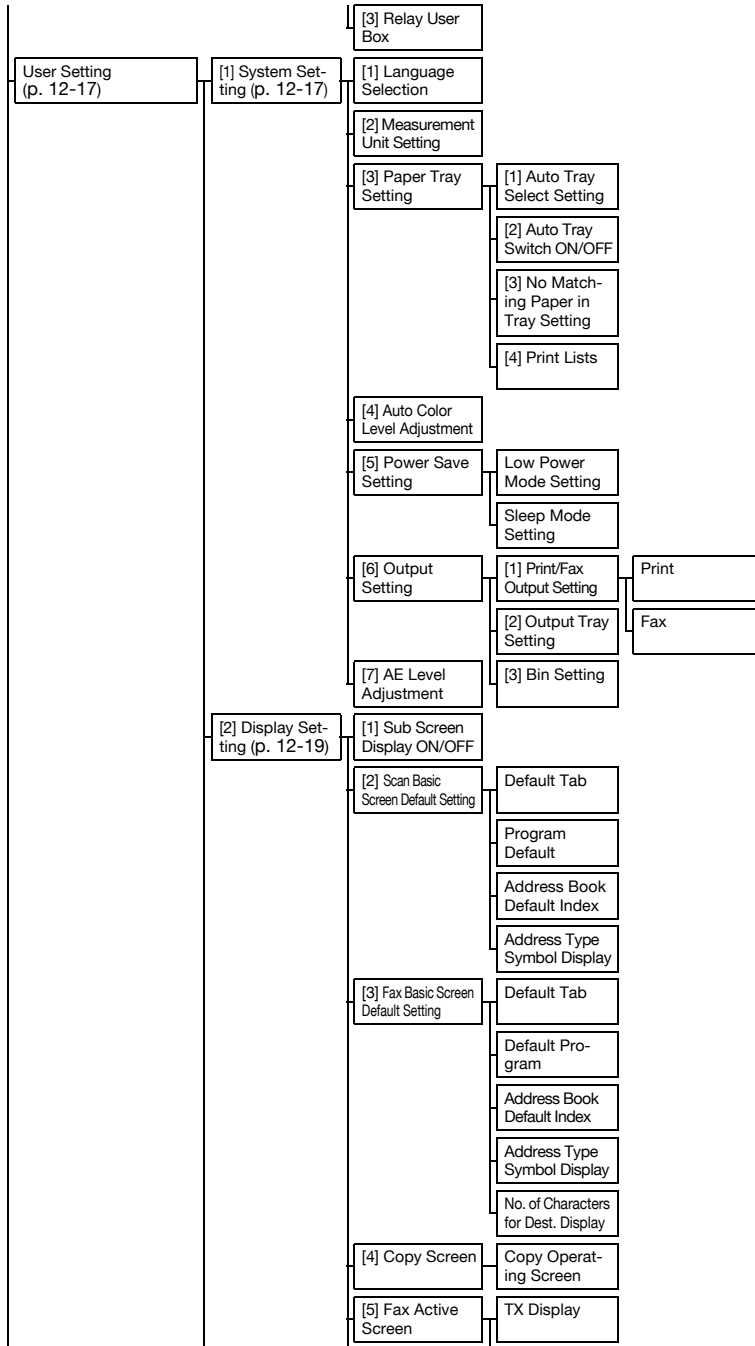

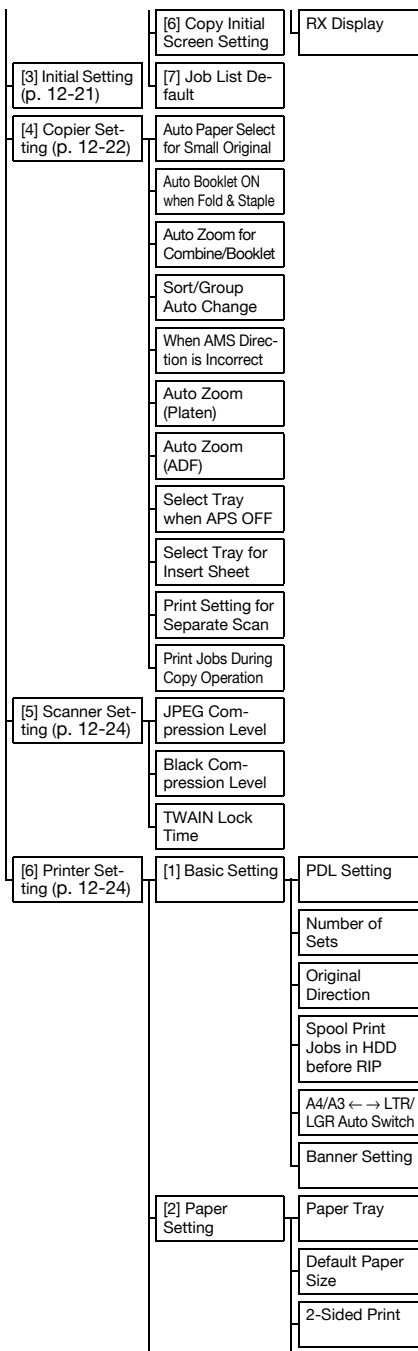

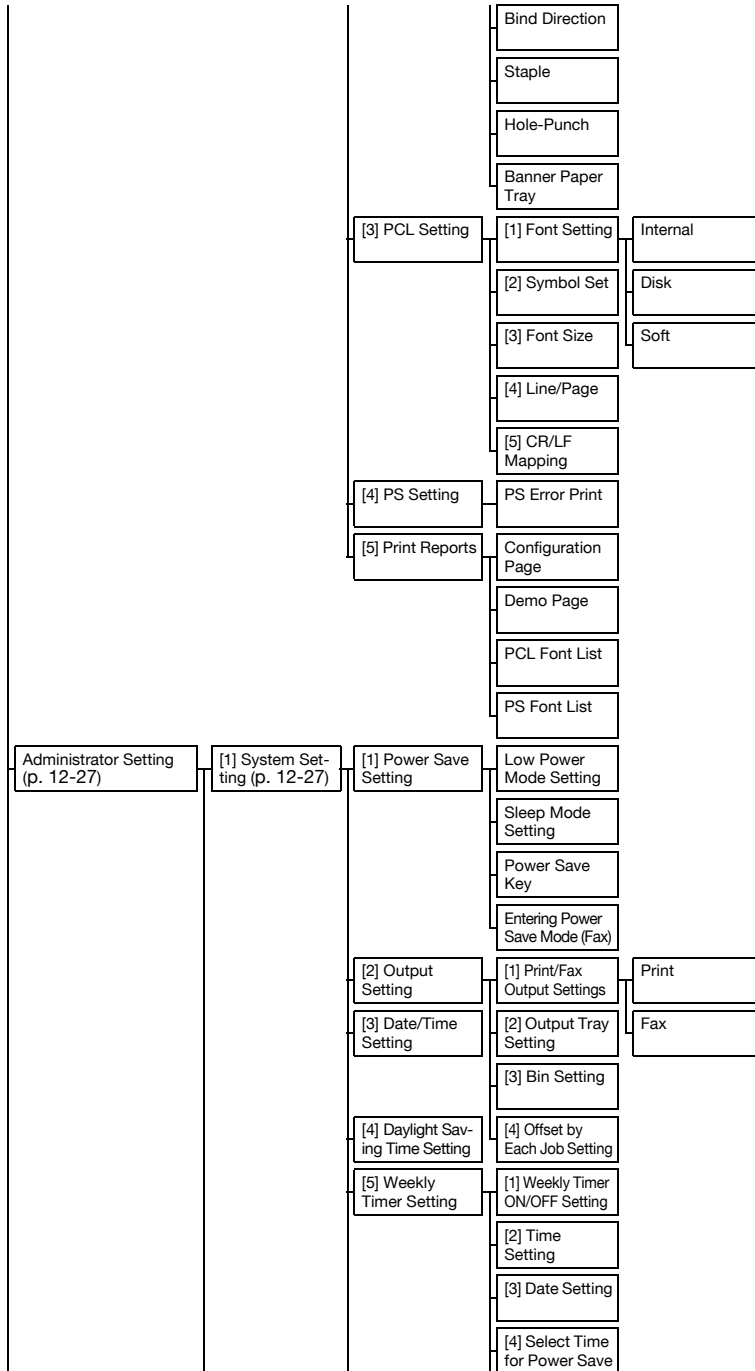

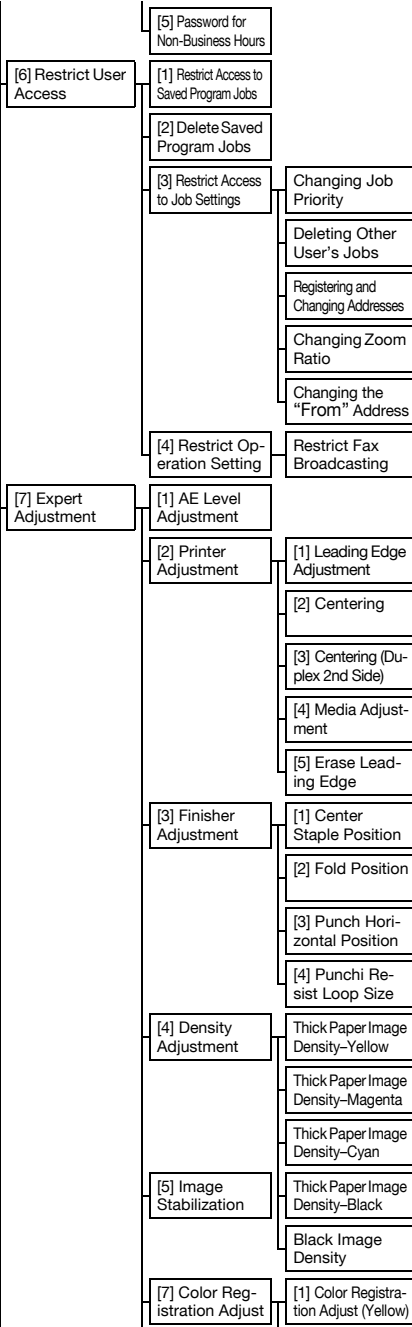

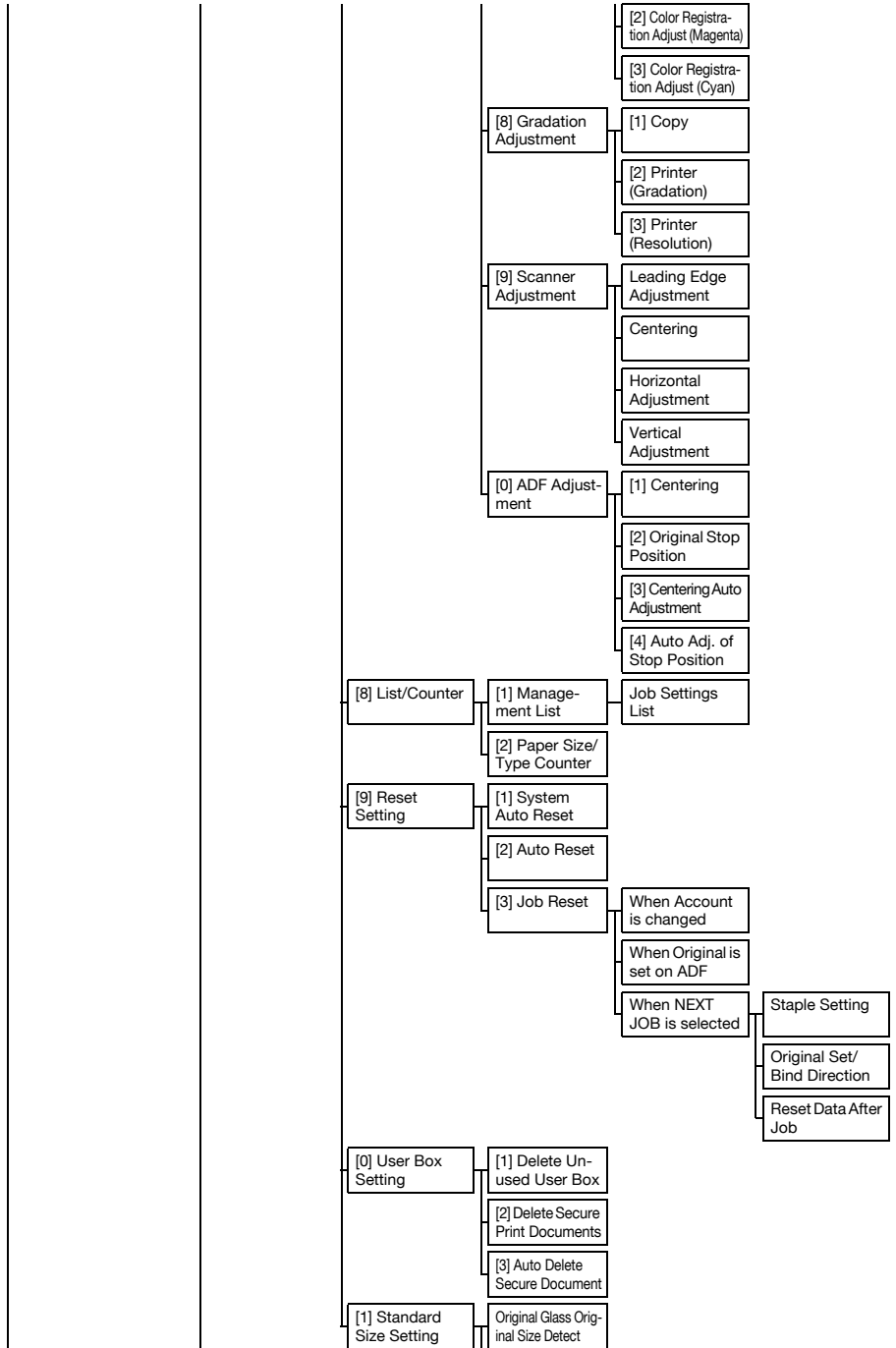

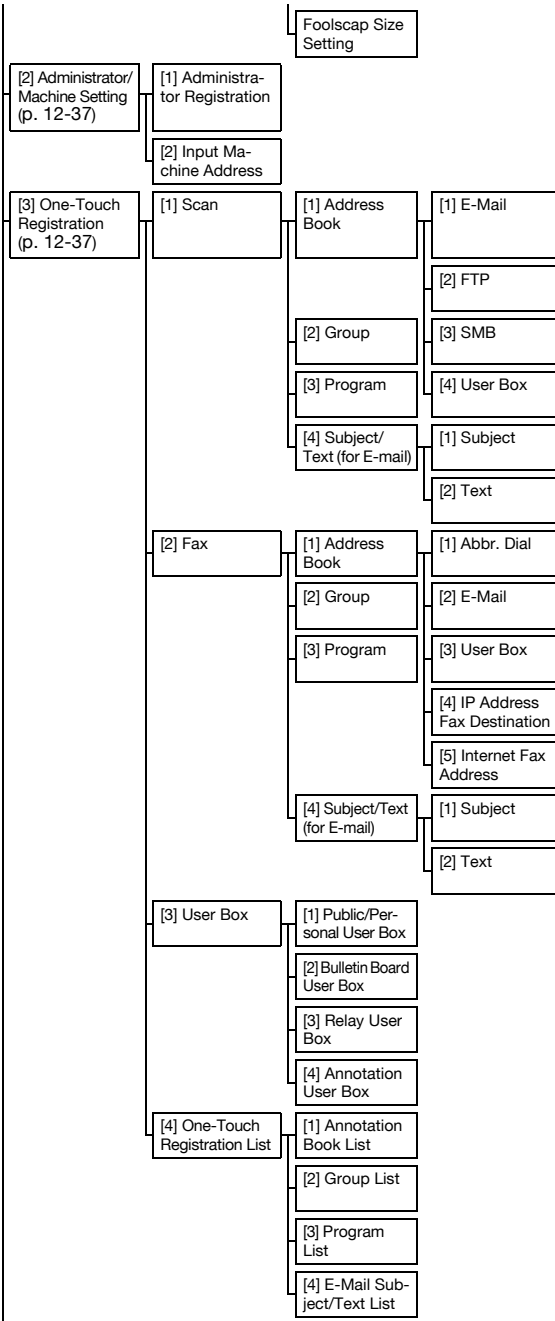

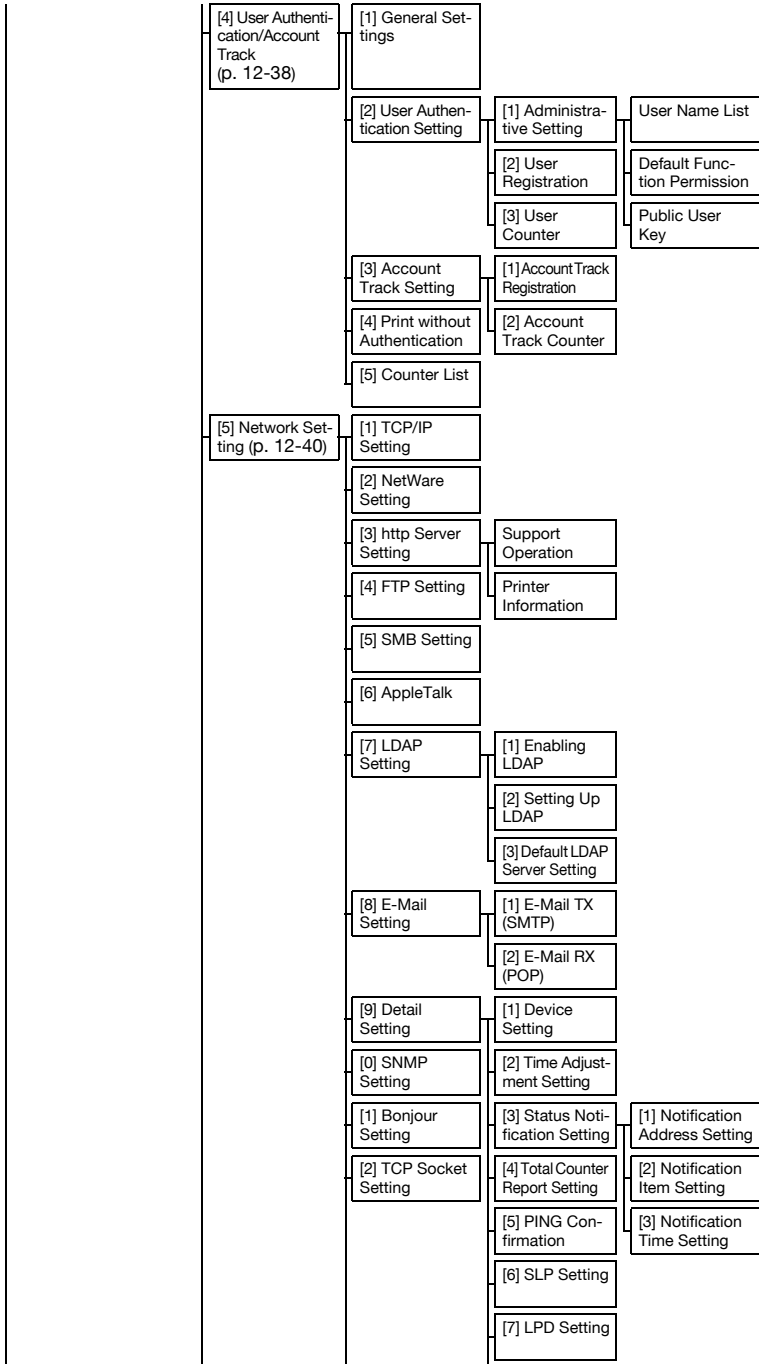

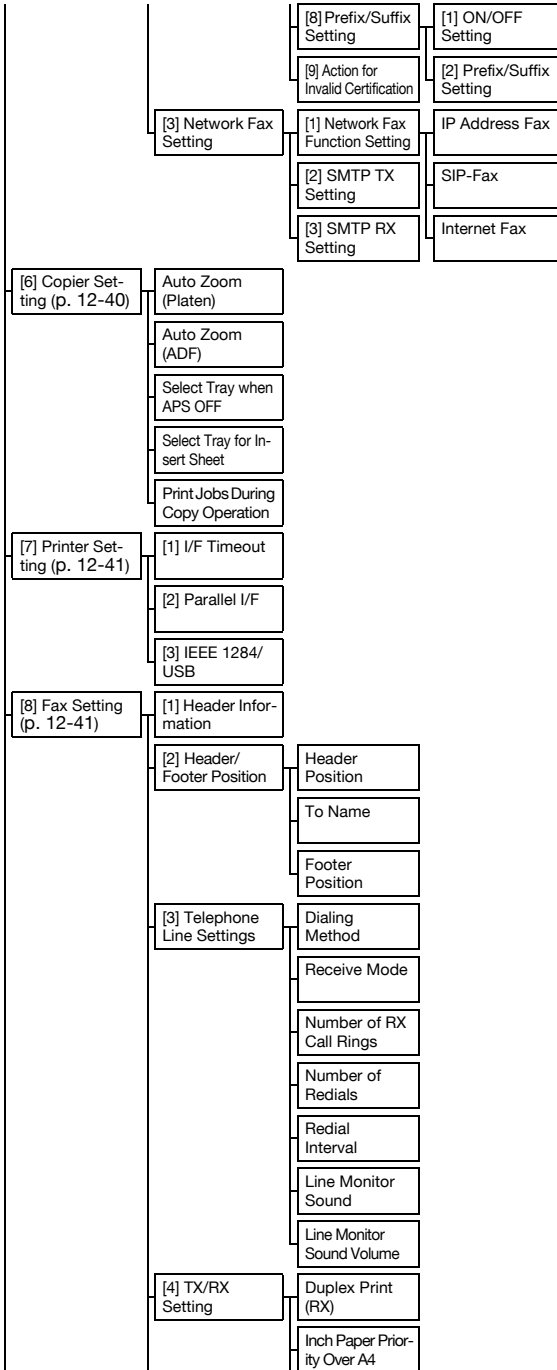

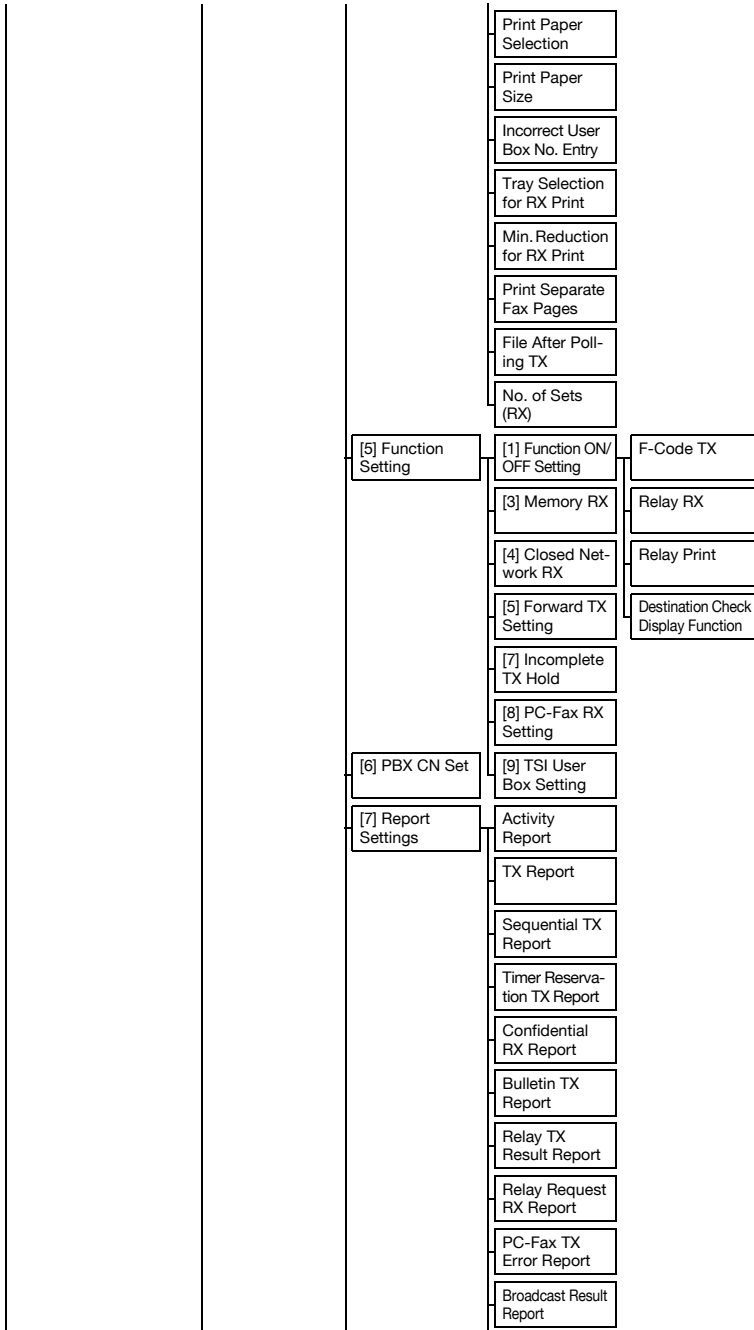

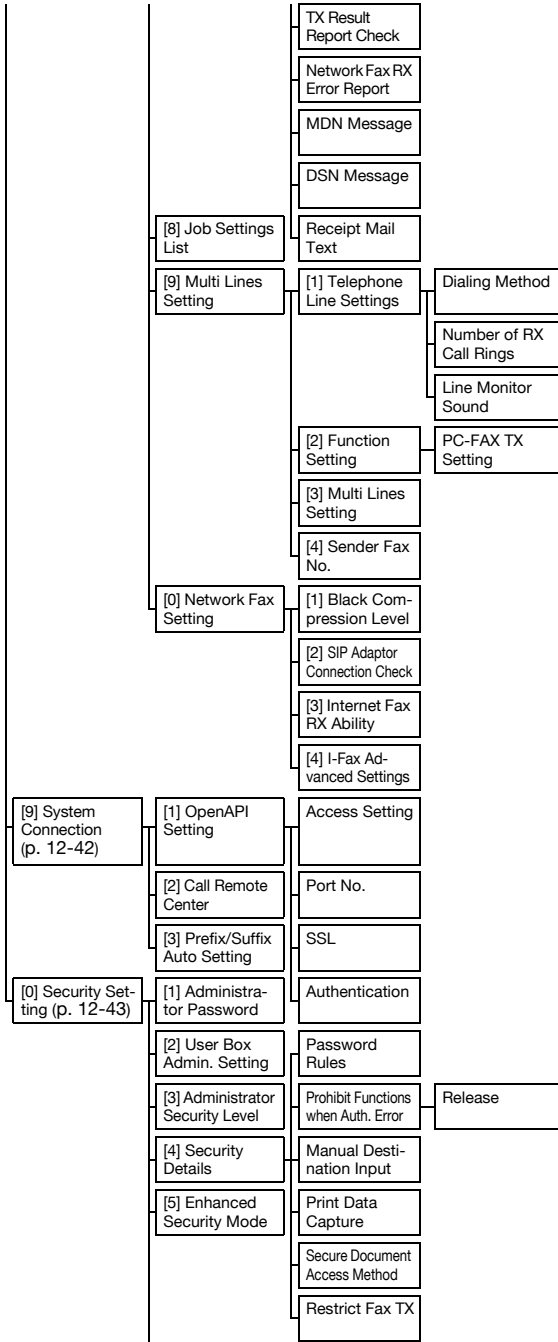

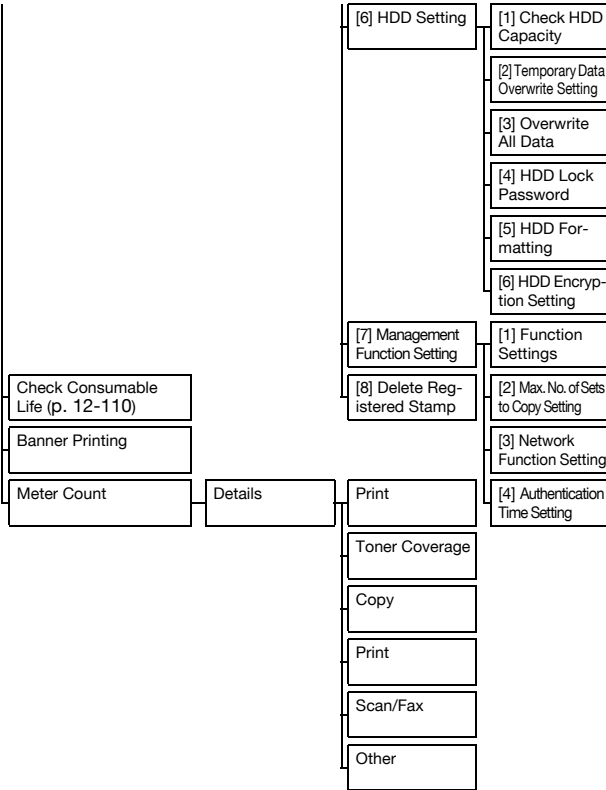

12.2 Selecting a destination register

This section describes the main parameters and operations that can be performed after pressing the [Utility/Counter] key, then touching [1 One-Touch Registration].

Scan

Parameter	Description
Address Book	Register recipients for scanning. For details, refer to the Network Scanner Operations of the User's Guide.
Group	
Program	
Subject/Text (for E-mail)	
Relay User Box	



Note

If user authentication has been set to "ON", [1 One-Touch Registration] does not appear when no user has logged on. However, after a user has logged on, [1 One-Touch Registration] appears.

Fax

Parameter	Description
Address Book	Register recipients for faxing. For details, refer to the Facsimile Operations and the Network Facsimile Operations of the User's Guide.
Group	
Program	
Subject/Text (for E-mail)	



Note

[2 Fax] appears only when fax kit FK-502 is installed or when Internet fax functions are available.

User box

Parameter	Description
Public/Personal User Box	Register recipients for boxes. For details, refer to the Box Operations of the User's Guide.
Bulletin Board User Box	
Relay User Box	

**Note**

[2 Bulletin Board User Box] and [3 Relay User Box] appear only when fax kit FK-502 is installed or when Internet fax functions are available.

Displaying the destination register screen

The following procedure describes how to display the One-Touch Registration Screen.

- 1 Press the [Utility/Counter] key.

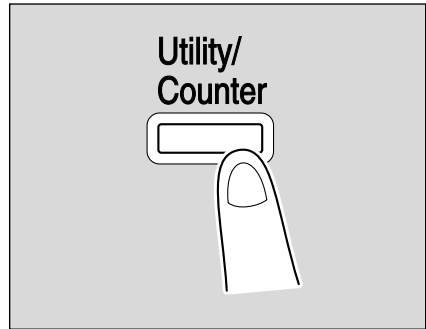

- 2 Touch [1 One-Touch Registration].

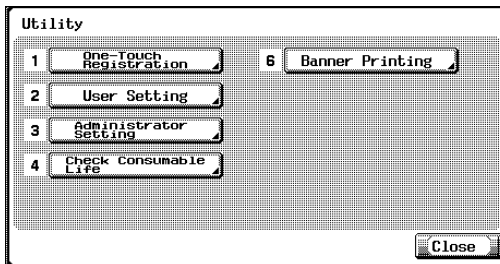

- An item can also be selected by pressing the key in the keypad for the number beside the desired button.
For "One-Touch Registration" press the [1] key in the keypad.

The One-Touch Registration screen appears.

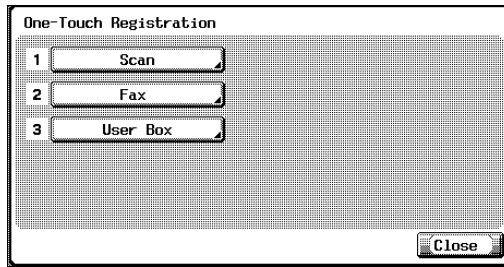

Note

To quit specifying the Utility mode setting, touch [Exit] in the sub display area or press the [Utility/Counter] key. Otherwise, cancel the Utility mode by touching [Close] in each screen until the screen for the Copy, Fax, Scan or Box mode appears.

12.3 Specifying user settings

This section describes the main parameters and operations that can be performed after pressing the [Utility/Counter] key, then touching [2 User Setting].

System setting

Language Selection

Description	Default Setting
Select the language of the Touch Panel messages.	English

Measurement Unit Setting

Description	Default Setting
Select one of the following as the measurement units in which values are displayed in the touch panel. inch (Fraction), inch (Numerical Value), mm (Numerical Value)	inch (Fraction)

Paper Tray Setting

Parameter	Description	Default Setting
Auto Tray Select Setting	Select the paper trays that are selected automatically when the Auto Paper Select setting is performed. In addition, specify the priority of the paper trays when the ATS feature is performed.	Tray 2 → Tray 3 → Tray 4 → Tray 1
Auto Tray Switch ON/OFF	Select whether or not a paper tray loaded with paper of the same size is selected automatically when a paper tray becomes empty while printing copies.	Restrict
No Matching Paper in Tray Setting	Select the operation that is performed when there is no paper of the corresponding size in the specified paper tray. <ul style="list-style-type: none"> Stop Printing (Tray Fixed): The machine stops operating. Switch Trays (Tray Priority): Whether or not the specified paper tray contains paper of the corresponding size is determined and, if it does not, a different paper tray is selected if it contains paper of the corresponding size. 	Stop Printing (Tray Fixed)
Print Lists	Select the paper tray used for printing lists, such as the sales counter and consumables indicators.	Tray 1

Auto Color Level Adjustment

Description	Default Setting
Adjust the reference level for detecting a color or black-and-white document when the "Auto Color" setting is selected. The reference level can be set to one of 5 settings.	3 (standard)

Power Save Setting

Parameter	Description	Default Setting
Low Power Mode Setting	Specify the desired length of time (between 10 and 240 minutes) until the machine enters Low Power mode.	15 minutes
Sleep Mode Setting	Specify the desired length of time (between 15 and 240 minutes) until the machine enters Sleep mode.	30 minutes

**Note**

If the "Administrator Security Level" parameter in Administrator mode was set, [Power Save] does not appear.

**Detail**

For details on the "Administrator Security Level" parameter, refer to "Security setting" on page 12-43.

Output Setting

Parameter	Description
Print/Fax Output Setting	Specify settings for faxing and printing. For details, refer to the Facsimile Operations and Print Operations of the User's Guide.
Output Tray Setting	Select the copy exit tray for each type of job (copies, printouts, faxes and reports). Finisher FS-514 Copy: Tray 1 Print: Tray 1 Report Output: Tray 3 Fax: Tray 3 Finisher FS-501 Copy: Tray 2 Print: Tray 2 Report Output: Tray 1 Fax: Tray 1
Bin Setting	The output tray 1 can be specified as mailbin 5 and the optional output tray can be specified as mailbin 6. Disable



Reminder

The “Output Tray Setting” parameter is available only if optional finisher FS-514 or finither FS-501 is installed.

[Bin Setting] only appears if the mailbin kit is installed.

“Tray 2” appears for the “Bin Setting” parameter only if the output tray is installed.

AE Level Adjustment

Description	Default Setting
Specify the initial value for auto exposure. The higher the setting, the more that the document background is emphasized.	2 (standard)



Note

If the “Administrator Security Level” parameter in Administrator mode was set to “Level 2”, [Output Setting] and [AE Level Adjustment] also appear.

Display setting

Sub Screen Display ON/OFF

Description	Default Setting
Sub Screen Display Type <ul style="list-style-type: none"> • Setting value: An image of the selected setting is displayed. • Job List: A list of the jobs that are being performed is displayed. 	Setting value

Scan Basic Screen Default Setting

Parameter	Description
Default Tab	Specify settings for scanning. For details, refer to the Network Scanner Operations of the User’s Guide.
Program Default	
Address Book Default Index	
Address Type Symbol Display	

Fax Basic Screen Default Setting

Parameter	Description
Default Tab	Specify settings for faxing. For details, refer to the Facsimile Operations and the Network Facsimile Operations of the User's Guide.
Default Program	
Address Book Default Index	
Address Type Symbol Display	
No. of Characters for Dest. Display	

Copy Screen

Parameter	Description	Default Setting
Copy Operating Screen	Select the screen that is displayed while printing. <ul style="list-style-type: none"> • ON: A copy job can be reserved by touching [Program Next Job] in the screen with the message "Now printing.", which appears during printing. • OFF: A copy job can be reserved while the Basic screen in Copy mode is displayed. 	OFF

Fax Active Screen

Parameter	Description
TX Display	Specify settings for faxing. For details, refer to the Facsimile Operations and the Network Facsimile Operations of the User's Guide.
RX Display	

Copy Initial Screen Setting

Description	Default Setting
Specify the default display for the Basic screen in Copy mode. <ul style="list-style-type: none"> • TYPE1: Buttons for selecting functions and the current settings are displayed in the Basic screen. • TYPE2: Some buttons for selecting functions are displayed in the Basic screen, and the current settings are highlighted. 	TYPE1

Job List Default

Description	Default Setting
Select the job list displayed as the default in the Job List screen. <ul style="list-style-type: none"> • Current Print Jobs: The Current Jobs list appears on the Print tab. • Print Job History: The Job History list appears on the Print tab. 	Current Print Jobs

Initial setting

Description	Default Setting
Specify the default settings for Copy mode. The copy settings selected when the machine is turned on (the power switch is set to "I") or the [Reset] key is pressed can be specified. <ul style="list-style-type: none"> • Current Setting: The settings specified from the touch panel before Utility mode was entered are set as the default settings for Copy mode. • Factory Default: The factory default settings are set as the default settings for Copy mode. 	Factory Default



Reminder

To change the default settings for Scan mode or Fax mode, press the [Scan] or [Fax] key, enter Utility mode, and then select a setting for this parameter.



Detail

For details on the default settings and the factory default settings, refer to "Automatically canceling the settings (automatic panel reset)" on page 2-34.

Copier setting

Parameter	Description	Default Setting
Auto Paper Select for Small Original	<p>Select whether copying is permitted when the "Auto Paper Select" setting is selected and either no document is placed on the original glass or the document placed on the original glass is too small for its size to be detected.</p> <ul style="list-style-type: none"> • Copy on Small Size: The document size is determined to be 5-1/2 × 8-1/2, and copies are produced on 5-1/2 × 8-1/2-size paper. • Copy on Letter: The document size is determined to be 8-1/2 × 11, and copies are produced on 8-1/2 × 11-size paper. • Prohibit Copy: Copies cannot be produced since the document size cannot be detected. Before pressing the [Start] key, the paper tray (paper to be printed on) must be selected. 	Prohibit Copy
Auto Booklet ON when Fold & Staple	<p>Select whether or not the "Booklet" function is selected automatically when the "Fold & Staple" setting is selected. This parameter is available only if optional saddle stitcher or finisher FS-603 is installed.</p>	Auto Select Booklet
Auto Zoom For Combine/Booklet	<p>Select whether or not the preset zoom ratios are automatically selected when "Auto Paper Select" is set and a Combine Originals or Booklet setting is selected.</p> <ul style="list-style-type: none"> • Auto Display Zoom Ratio: The following zoom ratios are set. 2 in 1, Booklet × 0.647 4 in 1 × 0.500 8 in 1 × 0.323 • OFF: No zoom ratio is selected automatically. 	Auto Display Zoom Ratio
Sort/Group Auto Change	<p>Select whether or not the "Sort" setting is automatically selected when 2 or more copies are set to be printed in a single job.</p> <ul style="list-style-type: none"> • ON: When a document is loaded into the ADF and the [Start] key is pressed, the "Group" setting is automatically selected if the document consists of only one page or the "Sort" setting is automatically selected if the document consists of two or more pages. • OFF: The "Sort" and "Group" settings are not selected automatically. 	ON

Parameter	Description	Default Setting
When AMS Direction is Incorrect	<p>Select whether or not printing continues when the paper and document orientations are different with the “Auto Paper Select” setting selected.</p> <ul style="list-style-type: none"> • Print: The Zoom setting is automatically set and the copy is printed on paper of the specified size in the specified orientation. • Delete Job: The job is deleted, and no copies are printed. 	Print
Auto Zoom (Platen)	Select whether or not a Zoom setting is automatically selected when a paper tray is selected (except when “Auto Paper Select” is set) while a document is placed on the original glass.	OFF
Auto Zoom (ADF)	Select whether or not a Zoom setting is automatically selected when a paper tray is selected (except when “Auto Paper Select” is set) while a document is loaded into the ADF.	ON
Select Tray when APS OFF	<p>Select which paper tray is selected when the “Auto Paper Select” setting is canceled.</p> <ul style="list-style-type: none"> • Tray Before APS ON: The paper tray that was being used before the “Auto Paper Select” setting was selected is selected. • Default Tray: The 1st tray is used. 	Tray Before APS ON
Select Tray for Insert Sheet	Select the default paper tray loaded with paper for the cover pages, inserted pages and chapter title pages.	Tray 2
Print Setting for Separate Scan	<p>Select whether copies are printed as the document is being scanned or after the entire document has been scanned when scanning a document in separate batches or when scanning a multiple-page document from the original glass.</p> <ul style="list-style-type: none"> • Auto Print: Printing of copies that can be printed begins while the document is being scanned. • Batch Print: Printing begins after all pages of the document have been scanned. 	Auto Print
Print Jobs During Copy Operation	<p>Select whether or not print data or fax data can be accepted for printing while a copy operation is being performed.</p> <ul style="list-style-type: none"> • Accept: Print data and fax data can be accepted and printed. • Receive Only: Print data and fax data is printed after the copy operation is finished. 	Accept

**Note**

If the “Administrator Security Level” parameter in Administrator mode was set, [Auto Zoom (Platen)], [Auto Zoom (ADF)], [Select Tray when APS OFF], and [Select Tray for Insert Sheet] do not appear.

If the “Administrator Security Level” parameter in Administrator mode was set to “Level 2”, [Print Jobs During Copy Operation] does not appear.

**Detail**

For details on the “Administrator Security Level” parameter, refer to “Security setting” on page 12-43.

Scanner setting

Parameter	Description
JPEG Compression Level	Specify settings for scanning. For details, refer to the Network Scanner Operations of the User’s Guide.
Black Compression Level	
TWAIN Lock Time	

Printer setting

Parameter	Description
Basic Setting	Specify settings for printing. For details, refer to the Print Operations of the User’s Guide.
Paper Setting	
PCL Setting	
PS Setting	
Print Reports	The Print function settings can be printed as a report. For details, refer to the Print Operations of the User’s Guide.

Displaying the Utility Setting screen

The following procedure describes how to display the User Setting Screen.

- 1 Press the [Utility/Counter] key.

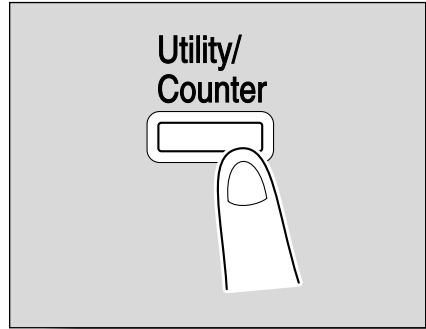

- 2 Touch [2 User Setting].

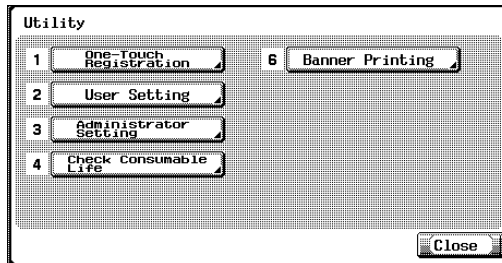

- An item can also be selected by pressing the key in the keypad for the number beside the desired button.
For “2 User Setting”, press the [2] key in the keypad.

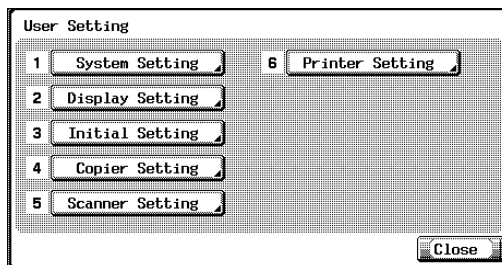

The User Setting screen appears.

**Note**

To quit specifying the User mode setting, touch [Exit] in the sub display area or press the [Utility/Counter] key. Otherwise, cancel the User mode by touching [Close] in each screen until the screen for the Copy, Fax, Scan or Box mode appears.

**Detail**

For details on “Banner Printing”, refer to the User’s Guide [Print Operations].

12.4 Specifying administrator settings

This section describes the main parameters and operations that can be performed after pressing the [Utility/Counter] key, then touching [3 Administrator Setting].

System setting

Power Save Setting

Parameter	Description	Default Setting
Low Power Mode Setting	Specify the desired length of time (between 10 and 240 minutes) until the machine enters Low Power mode.	15 minutes
Sleep Mode Setting	Specify the desired length of time (between 15 and 240 minutes) until the machine enters Sleep mode.	30 minutes
Power Save Key	Select which low power mode is entered when the [Power Save] key is pressed. <ul style="list-style-type: none"> Low Power: The touch panel goes off and the machine enters a mode where it conserves energy. Sleep: Although the machine conserves more energy in Sleep mode than in Low Power mode, the machine must warm up when Sleep mode is canceled, therefore taking more preparation time than Low Power mode. 	Low Power
Entering Power Save Mode (Fax)	Specify settings for faxing. For details, refer to the Facsimile Operations and the Network Facsimile Operations of the User's Guide.	Normal

Output Setting

Parameter	Description	Default Setting
Print/Fax Output Settings	Specify settings for faxing and printing. For details, refer to the Facsimile Operations and Print Operations of the User's Guide.	
Output Tray Setting	Select the copy exit tray for each type of job (copies, printouts, faxes and reports).	Finisher FS-514 Copy: Tray 1 Print: Tray 1 Report Output: Tray 3 Fax: Tray 3 Finisher FS-501 Copy: Tray 2 Print: Tray 2 Report Output: Tray 1 Fax: Tray 1
Bin Setting	The output tray 1 can be specified as mailbin 5 and the optional output tray can be specified as mailbin 6.	Disable

Parameter	Description	Default Setting
Offset by Each Job Setting	<p>Select whether or not printed copies are fed out shifted when "Offset" is selected while a finisher FS-514 is installed.</p> <ul style="list-style-type: none"> • ON: Pages are fed out shifted. • OFF: Pages are fed out without being shifted. 	ON



Reminder

The "Output Tray Setting" parameter is available only if optional finisher FS-514 or finisher FS-501 is installed.

[Bin Setting] only appears if the mailbin kit is installed.

"Tray 2" appears for the "Bin Setting" parameter only if the output tray is installed.

[Offset by Each Job Setting] appears only if finisher FS-514 is installed.

Date/Time Setting

Description	Default Setting
Specify the current date and time. In addition, the time zone can be set between -12:00 and 13:00 (in 30-minute increments).	Time Zone: +00:00

Daylight Saving Time Setting

Description	Default Setting
Select whether or not the machine's internal clock observes daylight saving time. If "ON" is selected, a setting appears so that the length of time for adjusting the current time can be set. The daylight saving time can be set between 1 and 150 minutes in 1-minute increments.	OFF

Weekly Timer Setting

Parameter	Description	Default Setting
Weekly Timer ON/OFF Setting	Select whether or not the weekly timer function is used.	OFF
Time Setting	Specify the time of each day that the machine is turned on/off.	–
Date Setting	Specify the individual dates or the days of the week that the machine is turned on/off.	–
Select Time for Power Save	If the machine is turned off at a specific time, for example, during the lunch break, the time for turning the machine off and on can be specified.	OFF
Password for Non-Business Hours	If the machine is turned off with a weekly timer, select whether or not use is limited with a password. In addition, if "ON" is selected, specify the password that must be entered.	OFF

**Detail**

If the weekly timer is set, the machine will be turned on/off at the specified time. Settings can be specified to require a password in order to turn the machine on or to allow fax and print jobs to be received after the machine has been turned off by the timer.

Various weekly timer settings in the Weekly Timer Setting screen can be combined. For details on the various settings, refer to "Overview of weekly timer settings" on page 12-49.

Restrict User Access

Parameter		Description	Default Setting
Restrict Access to Saved Program Jobs		Select the registered copy programs that are prevented from being changed or deleted.	–
Delete Saved Program Jobs		Select the registered copy programs to be delete.	–
Restrict Access to Job Settings	Changing Job Priority	Select whether or not to allow the print priority of jobs to be changed.	Allow
	Deleting Other User's Jobs	Select whether or not jobs from other users can deleted when the user authentication settings have been specified.	Restrict
	Registering and Changing Addresses	Select whether or not to allow registered recipients to be changed.	Allow
	Changing Zoom Ratio	Select whether or not to allow stored zoom ratios to be changed.	Allow
	Changing the "From" Address	Select whether or not to allow the specified From address to be changed.	Allow
Restrict Operation Setting	Restrict Fax Broadcasting	Select whether to prevent multiple recipients from being specified for fax transmissions.	OFF

Expert Adjustment

Parameter	Description	Default Setting
AE Level Adjustment	Set the initial value for auto exposure between 0 and 4. The higher the setting, the more that the document background is emphasized.	2 (standard)

Parameter		Description	Default Setting
Printer Adjustment	Leading Edge Adjustment	Adjust the starting print position between -3.0 and 3.0 mm at the leading edge of the paper (with respect to the paper feed direction). Adjustments can be specified for each paper type.	0.0 mm
	Centering	Adjust the starting print position between -3.0 mm and 3.0 mm at the left edge of the paper (with respect to the paper feed direction). Adjustments can be specified for each paper tray.	0.0 mm
	Centering (Duplex 2nd Side)	Adjust the starting print position between -3.0 mm and 3.0 mm at the left edge of the paper for the second side during automatic double-sided copying. Adjustments can be specified for each paper tray.	0.0 mm
	Media Adjustment	If the print image is flawed (missing print, white spots, or uneven printing) due to the characteristics of the type of paper that is used, adjust this parameter between -5 and +5 according to the paper type.	-
	Erase Leading Edge	The width of the area erased from the leading edge (margin) can be adjusted to 4 mm, 5 mm, or 7 mm. For details on making this adjustment, contact your technical representative.	4 mm
Finisher Adjustment	Center Staple Position*	Adjust the center stapling position between -10 mm and 10 mm for printing with the "Fold & Staple" setting.	0 mm
	Fold Position*	Adjust the center folding position between -10 mm and 10 mm for printing with the "Half Fold" setting.	0 mm
	Punch Horizontal Position*	Adjust the horizontal position of the punched holes between -10 mm and +10 mm.	0 mm
	Punch Resist Loop Size*	The hole-punching shift for double-sided printing and outputting cover pages can be adjusted in 1 mm increments.	0 mm
	Center Staple Position**	Adjust the center stapling position between -7 mm and 7 mm for printing with the "Fold & Staple" setting.	0 mm
	Half-Fold Position**	Adjust the center folding position between -7 mm and 7 mm for printing with the "Half Fold" setting.	0 mm

Parameter		Description	Default Setting
Density Adjustment	Thick Paper Image Density–Yellow	Adjust the image density for printing on thick paper, overhead projector transparencies, or envelopes. The density can be adjusted separately for each color (yellow, magenta, cyan and black for a color image and the black image density). The higher the setting, the darker the density. Adjust the setting for yellow, magenta, cyan and black between –5 and +5. Adjust the setting for “Black Image Density” between –2 and +2.	0
	Thick Paper Image Density–Magenta		0
	Thick Paper Image Density–Cyan		0
	Thick Paper Image Density–Black		0
	Black Image Density		0
Image Stabilization		Perform an image stabilization if the image is incorrect, even after the gradation levels have been adjusted. <ul style="list-style-type: none"> Image Stabilization Only: Perform normal image stabilization. Initialize + Image Stabilization: Select when a good result was not achieved after “Image Stabilization Only” was selected. 	–
Color Registration Adjust	Color Registration Adjust (Yellow)	Adjust the color registration if color shifts can be seen in the print result.	–
	Color Registration Adjust (Magenta)		–
	Color Registration Adjust (Cyan)		–
Gradation Adjustment	Copy	Adjust the gradation if there are changes in the color gradations of the print image. The adjustment is made with stress on increasing the number of images stored in the memory.	–
	Printer (Gradation)	Adjust the gradation if there are changes in the color gradations of the print image. The adjustment is made with stress on the gradations in images.	–
	Printer (Resolution)	Adjust the gradation if there are changes in the color gradations of the print image. The adjustment is made with stress on the reproducibility of text and lines.	–

Parameter		Description	Default Setting
Scanner Adjustment	Leading Edge Adjustment	The starting scanning position (document feed direction) of the document can be adjusted. For details on making this adjustment, contact your technical representative.	
	Centering	The starting scanning position (transverse document feed direction) of the document can be adjusted. For details on making this adjustment, contact your technical representative.	
	Horizontal Adjustment	If the copy image is distorted (stretched or compressed), the zoom ratio in the transverse document feed direction for the scanner can be adjusted. For details on making this adjustment, contact your technical representative.	
	Vertical Adjustment	If the copy image is distorted (stretched or compressed), the zoom ratio in the document feed direction for the scanner can be adjusted. For details on making this adjustment, contact your technical representative.	
ADF Adjustment	Centering	If the center position cannot be automatically adjusted in the transverse document feed direction, it can be adjusted manually. For details on making this adjustment, contact your technical representative.	
	Original Stop Position	If the scanning position cannot be automatically adjusted in the document feed direction, it can be adjusted manually. For details on making this adjustment, contact your technical representative.	
	Centering Auto Adjustment	The center position in the transverse document feed direction can be adjusted automatically. For details on making this adjustment, contact your technical representative.	
	Auto Adj. of Stop Position	The scanning position in the document feed direction can be adjusted automatically. For details on making this adjustment, contact your technical representative.	



Detail

For the procedure on adjusting the printer, refer to “Adjusting the printer” on page 12-50.

For the procedure on adjusting the finisher, refer to “Adjusting the finisher (FS-603)” on page 12-66.

The Finisher Adjustment parameters that are available differ depending on the installed finisher.

** Available only if the saddle stitcher is installed on optional finisher FS-514.*

*** Available only if optional finisher FS-603 is installed.*

For the procedure on adjusting the color registration, refer to “Adjusting the color registration for yellow, magenta and cyan” on page 12-72.

For the procedure on adjusting the gradation levels, refer to “Adjusting the gradation levels” on page 12-75.

For details on displaying [Erase Leading Edge], contact your technical representative.

For details on displaying [Scanner Adjustment] and [ADF Adjustment], contact your technical representative.

List/Counter

Parameter		Description
Management List	Job Settings List	The machine settings can be printed.
Paper Size/Type Counter		Store combinations of paper sizes and paper types to be counted.

Reset Setting

Parameter		Description	Default Setting
System Auto Reset		<p>Specify the desired length of time until the automatic system reset operation is performed.</p> <ul style="list-style-type: none"> • Priority Mode: Select the setting (“Copy”, “Scan” or “Fax”) for the mode that the machine enters when the automatic system reset operation is performed. • System Auto Reset Time: Specify the setting (between 1 and 9 minutes or “OFF”) for the desired length of time until the automatic system reset operation is performed. 	Priority mode: Copy System Auto Reset Time: 1 minute
Auto Reset		Select the setting (between 1 and 9 minutes or “OFF”) for the desired length of time until the automatic panel reset operation is performed for each mode (Copy, Scan and Fax).	Copy: 1 minute Scan: 1 minute Fax: 1 minute
Job Reset	When account is changed	Select whether or not the settings are reset when the user has changed. This machine detects that the user has changed when the optional key counter has been removed or when the [Access] key is pressed after entering user authentication and account track information.	Reset
	When original is set on ADF	Select whether or not the settings are reset when a document is loaded into the ADF.	Do Not Reset
	When Next Job is selected	Staple Setting: Select whether the same Staple setting from the previous job is set or the setting is canceled when that job begins and the settings for the next job can be specified.	OFF
		Original Set/Bind Direction: Select whether the same Original Direction and Margin settings from the previous job are set or the settings are canceled when that job begins and the settings for the next job can be specified.	OFF
	Reset Data After Job: Select whether the same settings for a scan operation or for a fax transmission from the previous job are set or the settings are canceled when that job is completed and the settings for the next job can be specified. (However, even if “OFF” is selected, the destination is cleared.)	ON	



Reminder





If user authentication or account track operations are being performed, they will be canceled after 1 minute, even if the “System Auto Reset” parameter has been set to “OFF”. However, the Enlarge Display mode is not canceled when the “System Auto Reset” parameter is set to “OFF”.

If user authentication settings have been specified or “Enhanced Security Mode” has been set to “ON”, logout from Administrator mode or user authentication mode will be performed according to the “System Auto Reset Time” parameter.

User Box Setting

Parameter	Description	Default Setting
Delete Unused User Box	Specify settings for using boxes. For details, refer to the User’s Guide [Box Operations].	
Delete Secure Print Documents		
Auto Delete Secure Document	Specify settings for using boxes. For details, refer to the User’s Guide [Box Operations].	1 day

Standard Size Setting

Parameter	Description	Default Setting
Original Glass Original Size Detect	Paper size table 1 or 2 can be selected to change the available settings when the paper size is detected. For details, contact your technical representative.	Table 1
Foolscap Size Setting	The Foolscap paper size can be changed. There are four Foolscap sizes: 220 × 330 mm, 8-1/2 × 13  , 8-1/4 × 13  , 8-1/8 × 13-1/4  , and 8 × 13  . For details, contact your technical representative.	8 × 13 



Note

For details on displaying [Standard Size Setting], contact your technical representative.

Administrator/machine setting

Parameter	Description
Administrator Registration	Specify the administrator information displayed in the Service/Administrator Information screen of the Help screens and the From address for sending e-mail from the machine.
Input Machine Address	The name of the machine and its e-mail address can be registered. The registered machine name is added to the names of files that are sent and to documents saved in boxes. As a default, the machine name is specified as "KMBT-C252". The registered e-mail address is used with Internet faxing.



Note

When entering the device name while registering the machine address, do not use characters that cannot be used by the operating system.

One-Touch registration

Parameter	Description
Scan	Specify settings for scanning, faxing and using the boxes. For details, refer to the Network Scanner Operations, Facsimile Operations, Network Facsimile Operations and Box Operations of the User's Guide.
Fax	
User Box	
One-Touch Registration List	The lists of abbreviated destinations, group destinations, program destinations and titles/text can be printed to be checked. For details, refer to the Network Scanner Operations, Facsimile Operations, Network Facsimile Operations and Box Operations of the User's Guide.



Note

[2 Fax] appears only when fax kit FK-502 is installed or when Internet fax functions are available.

User authentication/account track

General Settings

Description	Default Setting
<p>Specify settings for user authentication and account track for controlling the use of this machine.</p> <ul style="list-style-type: none"> • User Authentication: Select either "ON (External Server)" or "ON (MFP)" as the user authentication method. To quit user authentication, select "OFF". • Public User Access: Select whether or not the machine can be used an unregistered user. This parameter is not available if "User Authentication" is set to "OFF". • Account Track: Select whether or not account track is used to control the machine. • Account Track Input Method: To control authentication with an account name and password, select "Account Name & Password". To control authentication with only a password, select "Password Only". No setting can be selected when "Account Track" is set to "OFF". If both user authentication and account track settings have been specified, only "Account Name & Password" can be selected. • When # of Jobs Reach Maximum: To stop the job being printed and begin printing the next job when the limit specified for account track or user authentication is reached, select "Skip Job". To stop the machine when the limit specified for account track is reached, select "Stop Job". • Synchronize User Authentication & Account Track: Select whether or not user authentication and account track are linked. This appears only when "User Authentication" is set to "ON (External Server)" or "ON (MFP)" and "Account Track" is set to "ON". • # of User Counters Assigned for users: Adjust the number of users and accounts that can be registered. Example: When "# of User Counters" is set to "50", 950 accounts can be registered. 	<p>User Authentication: OFF Account Track: OFF</p>

User Authentication Setting

Parameter	Description	Default Setting
Administrative Setting	UserName List	Select whether or not a list of user names is displayed in the user authentication screen. OFF
	Default Function Permission	Operations that are possible with this machine can be limited when authenticating with an external server. Copy: Allow Scan: Allow Fax: Allow Print: Allow User Box: Allow Print TX Function: Allow
	Public User Key	Select whether or not the public user is authenticated with the user authentication screen when "Public User Access" on the General Settings screen is set to "Allow". Do Not Display

Parameter	Description	Default Setting
User Registration	The users of this machine can be registered. In addition, the password, output permissions, number of prints allowed, and function permissions can be specified for each user.	–
User Counter	The copy, printing, scan/fax use for each user can be checked.	–



Note

The user authentication parameters appear when “User Authentication” is set to “ON (External Server)” or “ON (MFP)” in the General Settings screen.

The account track parameters appear when “Account Track” is set to “ON” in the General Settings screen.

Account Track Setting

Parameter	Description
Account Track Registration	The accounts that can use this machine can be registered.
Account Track Counter	The copy, printer, scan/fax use for each account can be checked.

Print without Authentication

Description	Default Setting
Select whether or not printing is permitted without specifying a user or account. If printing is permitted, prints are counted for public users.	Restrict

Counter List

Description	Default Setting
The use for each user or account can be checked.	Tray 1

Network setting

Parameter	Description
TCP/IP Setting	Specify settings for using the network. For details, refer to the Network Scanner Operations of the User's Guide.
NetWare Setting	
httpServer Setting	
FTP Setting	
SMB Setting	
AppleTalk	
LDAP Setting	
E-Mail Setting	
Detail Setting	
SNMP Setting	
Bonjour Setting	
TCP Socket Setting	
Network Fax Setting	Specify settings for network faxing. For details, refer to the Network Facsimile Operations of the User's Guide.

Copier setting

Parameter	Description	Default Setting
Auto Zoom (Platen)	Select whether or not a Zoom setting is automatically selected when a paper tray is selected (except when "Auto Paper Select" is set) while a document is placed on the original glass.	OFF
Auto Zoom (ADF)	Select whether or not a Zoom setting is automatically selected when a paper tray is selected (except when "Auto Paper Select" is set) while a document is loaded into the ADF.	ON
Select Tray when APS OFF	Select which paper tray is selected when the "Auto Paper Select" setting is canceled. <ul style="list-style-type: none"> Tray Before APS ON: The paper tray that was being used before the "Auto Paper Select" setting was selected is selected. Default Tray: The 1st tray is used. 	Tray Before APS ON
Select Tray for Insert Sheet	Select the default paper tray loaded with paper for the cover pages, inserted pages and chapter title pages.	Tray 2

Parameter	Description	Default Setting
Print Jobs During Copy Operation	Select whether or not print data or fax data can be accepted for printing while a copy operation is being performed. <ul style="list-style-type: none"> • Accept: Print data and fax data can be accepted and printed. • Receive Only: Print data and fax data is printed after the copy operation is finished. 	Accept

Printer setting

Parameter	Description
I/F Timeout	Specify settings for printing. For details, refer to the Print Operations of the User's Guide.
Parallel I/F	
IEEE 1284/USB	

Fax setting

Parameter	Description
Header Information	Specify settings for faxing. For details, refer to the Facsimile Operations and the Network Facsimile Operations of the User's Guide.
Header/Footer Position	
Telephone Line Settings	
TX/RX Setting	
Function Setting	
PBX CN Set	
Report Settings	
Job Settings List	
Multi Line Settings	
Network Fax Setting	Specify settings for network faxing. For details, refer to the Network Facsimile Operations of the User's Guide.



Note

[8 Fax Setting] appears only when fax kit FK-502 is installed or when Internet fax functions are available.

System connection

Parameter	Description
OpenAPI Setting	Specify settings for using the network. For details, refer to the Network Scanner Operations of the User's Guide.
Call Remote Center	Used by the administrator to call the center when CS Remote Care is connected.
Prefix/Suffix Auto Setting	For details, refer to the Facsimile Operations of the User's Guide.

**Note**

[2 Call Remote Center] appears when center registration has been completed with CS Remote Care.

Security setting

Administrator Password

Description	Default Setting
The administrator password used to specify the Administrator mode settings can be specified or changed. The administrator password can contain between 0 and 8 digits (characters). If the "Password Rules" parameter is set to "ON", only an administrator password with 8 digits can be specified.	12345678

User Box Admin. Setting

Description
Specify settings for using boxes. For details, refer to the Box Operations of the User's Guide.

Administrator Security Level

Description	Default Setting
<p>Specify the range of Administrator mode parameters available to users.</p> <ul style="list-style-type: none"> • Level 1: "Power Save", "Auto Zoom (Platen)", "Auto Zoom (ADF)", "Select Tray when APS OFF", and "Select Tray for Insert Sheet" are available to users. • Level 2: "Power Save", "Output Setting", "Date/Time Setting", "Daylight Savings Time Setting", "AE Level Adjustment", "Auto Zoom (Platen)", "Auto Zoom (ADF)", "Select Tray when APS OFF", "Select Tray for Insert Sheet", and "Print Jobs During Copy Operation" are available to users. • Prohibit: None of the parameters that are available to users with "Level 1" or "Level 2" are available. 	Prohibit

Security Details

Parameter	Description	Default Setting
Password Rules	Select whether or not passwords are applied.	OFF
Prohibit Functions when Auth. Error	<p>Select the operations that are prohibited if user authentication failed.</p> <ul style="list-style-type: none"> • [Mode 1]: Operations cannot be performed for a fixed length of time. • [Mode 2]: Operations cannot be performed from the control panel if repeated authentication attempts failed. The number of failed authentication attempts can be set to between 1 and 5 times. <p>If operation of the control panel is restricted, touch [Release], and then select the items whose operation restrictions are canceled.</p> <ul style="list-style-type: none"> • [User & Group]: Operations for user authentication and account track • [Secure Print]: Operations for confidential documents • [User Box]: Operations for password-protected boxes • [SNMP]: Operations for SNMP v3 Write user authentication 	Mode 1
Manual Destination Input	Select whether or not a recipient can be typed in manually in a recipient input screen.	Allow
Print Data Capture	Select whether or not data for a print job can be captured. For details, refer to the Print Operations of the User's Guide.	
Secure Document Access Method	<p>The operation method for confidential documents can be viewed.</p> <p>If "Prohibit Functions when Auth. Error" is set to "Mode 1", this parameter is set to "Mode 1". If "Prohibit Functions when Auth. Error" is set to "Mode 2", this parameter is set to "Mode 2"</p> <p>[Mode 1]: Type in the ID and password for the confidential document, and then select the document.</p> <p>[Mode 2]: Type in the ID for the confidential document, and then type in the password after the document is selected.</p>	Mode 1
Restrict Fax TX	Select whether or not fax transmissions are prohibited.	OFF



Detail

The operation of the “Prohibit Functions when Auth. Error” parameter is performed with the following passwords.

User authentication passwords, account track passwords, box passwords, passwords for confidential documents, and the administrator password

If the control panel cannot be operated even after touching [Release] from the “Prohibit Functions when Auth. Error” parameter to specify the items whose operation restrictions are canceled or if operation is prohibited from a failed attempt to authenticate the administrator password, re-start the machine.



Reminder

When the machine is turned off, then on again with the main power switch, wait at least 10 seconds to turn the machine on after turning it off. The machine may not operate correctly if it is turned on immediately after being turned off.

Enhanced Security Mode

Description

Settings necessary for applying the Enhanced Security mode appear. Select whether or not to apply enhanced security settings when the necessary settings are specified. For details, contact your technical representative.

HDD Setting

Parameter	Description	Default Setting
Check HDD Capacity	Specify settings for using boxes. For details, refer to the Box Operations of the User's Guide.	
Temporary Data Overwrite Setting	Select whether or not image data is temporarily written to the hard disk with all operations for copying, scanning, faxing and computer printing. For details on the settings, refer to the User's Guide [Box Operations]. By specifying a setting on the Temporary Data Overwrite Setting screen, the area of the hard disk where image data is saved can be overwritten after the data is printed or sent, and the data can be erased. This process prevents disclosure of image data on the hard disk.	OFF

Parameter	Description	Default Setting
Overwrite All Data	Select this parameter to overwrite all data on the entire hard disk when returning or disposing of this machine in order to prevent disclosure of the data. For details on the settings, refer to the User's Guide [Box Operations]. Before performing this operation, contact your technical representative.	Mode 1
HDD Lock Password	Specify the password for protecting the data on the hard disk. For details, refer to the Box Operations of the User's Guide.	
HDD Formatting	Select this parameter to format the hard disk. For details, refer to the Box Operations of the User's Guide.	
HDD Encryption Setting	Appears when optional security kit is installed. Specify the settings for encrypting the hard disk. When a setting is specified, all data written to the hard disk is encrypted to protect it. If the encryption key is changed, the hard disk will be reformatted. For details, refer to the Box Operations of the User's Guide.	

Management Function Setting

Parameter	Description	Default Setting
Network Function Setting	Specify settings for network functions that are difficult to count when managing operations.	Allow



Note

For details on displaying [Function Setting], [Max. No. of Sets to Copy Setting] and [Authentication Time Setting], contact your technical representative.



Detail

When "Network Function Setting" is set to "Disable", the following operations cannot be performed.

- PC-FAX transmission
- Using the HDD TWAIN driver to view and retrieve documents in boxes
- Using the PageScope Box Operator to view and retrieve documents in boxes
- Using the PageScope Scan Direct to retrieve documents in boxes
- Using the PageScope Job Spooler to view and retrieve documents in boxes
- Box operations using the PageScope Web Connection (The Box tab does not appear.)

Delete Registered Stamp

Description

Select whether or not stamps registered for copy protection can be deleted.

Displaying the Administrator Setting screen

The following procedure describes how to display the Administrator Setting Screen.

- 1 Press the [Utility/Counter] key.

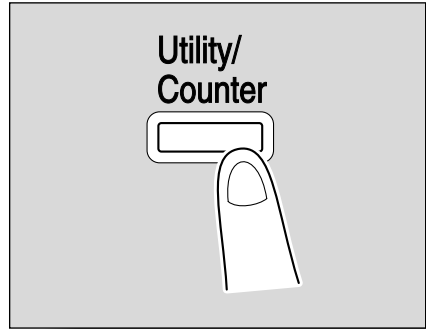

- 2 Touch [3 Administrator Setting].

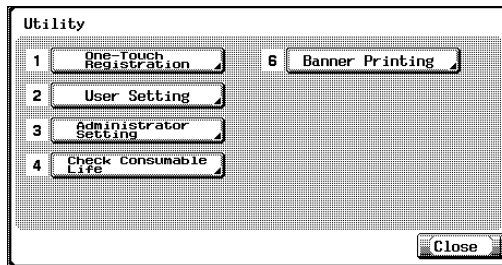

- An item can also be selected by pressing the key in the keypad for the number beside the desired button.
For "Administrator Setting", press the [3] key in the keypad.

- 3 Type in the administrator password, and then touch [OK].

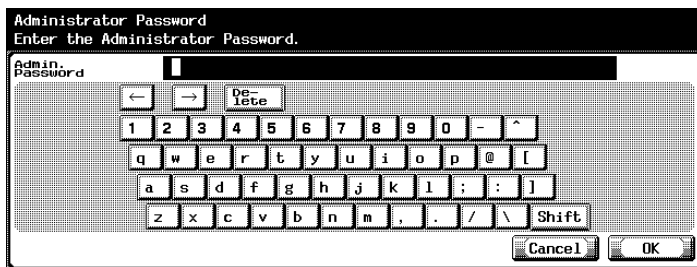

For details on typing in text, refer to “Entering text” on page 13-2.

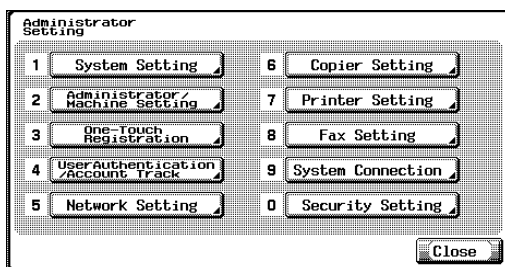

The Administrator Setting screen appears.



Note

To quit specifying the Utility mode setting, touch [Exit] in the sub display area or press the [Utility/Counter] key. Otherwise, touch [Close] in each screen until the desired screen appears.



Reminder

The default administrator password is “12345678”. The administrator of this machine should change the administrator password.

Be sure to keep the administrator password in a safe place. If the administrator password is lost, it must be specified by the technical representative. For details, contact the technical representative.

12.5 Overview of weekly timer settings

Various weekly timer settings in the Weekly Timer Setting screen can be combined. A general procedure is described below.

Requisite

- ✓ If the weekly timer has been set, leave the machine plugged into the electrical outlet even if the machine has been turned off.
- ✓ Press the [Utility/Counter] key, touch [3 Administrator Setting], then [1 System Setting] then [3 Date/Time Setting], and correctly specify the necessary settings.

- 1 Set “Weekly Timer ON/OFF Setting” to “ON”.
- 2 Specify times for “Time Setting”.
- 3 Specify dates for “Date Setting”.
- 4 Specify the desired settings for “Select Time for Power Save” and “Password for Non-Business Hours”.

The weekly timer is set.

12.6 Adjusting the printer

Adjusting the starting print position at the leading edge position

The starting print position at the leading edge of each type of paper (with respect to the paper feed direction) can be adjusted.

Adjustments can be specified for each paper type.

- ✓ The starting print position is adjusted during manufacturing of the machine. Normally, this position will not need to be adjusted.

- 1 Display the Administrator Setting screen.
 - For details on displaying the Administrator Setting screen, refer to “Displaying the Administrator Setting screen” on page 12-47.
- 2 Touch [1 System Setting].
The System Setting screen appears.
- 3 Touch [7 Expert Adjustment].
The Expert Adjustment screen appears.
- 4 Touch [2 Printer Adjustment].
The Printer Adjustment screen appears.
- 5 Touch [1 Leading Edge Adjustment].
The Leading Edge Adjustment screen appears.
- 6 Touch the button for the paper type to be set.

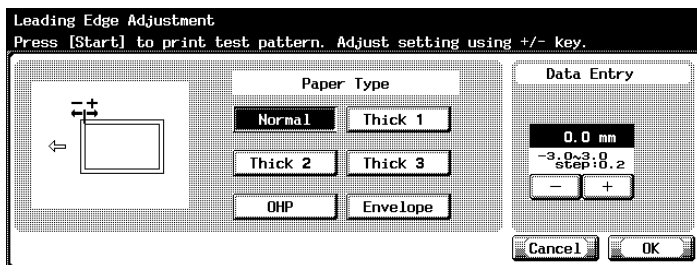

- 7 Press the [Start] key.
A test pattern is printed.

- 8 Check that the distance from the starting print position of the test pattern to the edge of the paper (a) is 4.2 mm.

- If the distance is less than 4 mm, touch [+]
to increase the adjustment (between 0.2 mm and 3.0 mm).
- If the distance is more than 7 mm, touch [-]
to reduce the adjustment (between -0.2 mm and -3.0 mm).
- To scroll through the values quickly, touch [+]
or [-] continuously.

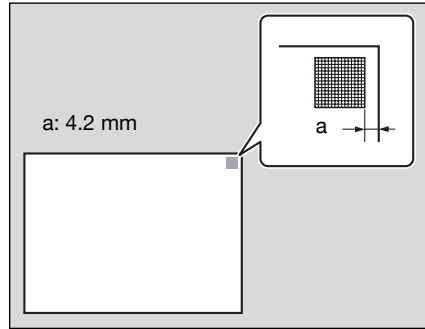

- 9 Press the [Start] key.

The adjusted test pattern is printed.

- 10 Check the distance from the starting print position of the test pattern to the edge of the paper.

- Check that the width has been adjusted to 4.2 mm.
- If more adjustment is necessary, repeat steps 8 and 9.
- To adjust the print position for a different type of paper, return to step 6.

- 11 Touch [OK].

- To cancel changes to the settings, touch [Cancel].
The print position is adjusted.



Note

Enter the value by mm using the keypad.

Refer to the conversion rate below.

1 in. = 25.4 mm

Adjusting the starting print position at the left edge

The starting print position at the left edge of the paper (with respect to the paper feed direction) for each paper tray can be adjusted.

Adjustments can be specified for each paper tray.

- ✓ The starting print position is adjusted during manufacturing of the machine. Normally, this position will not need to be adjusted.
- ✓ Only 8-1/2 × 11  paper can be used to adjust the bypass tray.

- 1 Display the Administrator Setting screen.
 - For details on displaying the Administrator Setting screen, refer to “Displaying the Administrator Setting screen” on page 12-47.
- 2 Touch [1 System Setting].
The System Setting screen appears.
- 3 Touch [7 Expert Adjustment].
The Expert Adjustment screen appears.
- 4 Touch [2 Printer Adjustment].
The Printer Adjustment screen appears.
- 5 Touch [2 Centering].
The Centering screen appears.
- 6 Touch the button for the paper tray to be set.

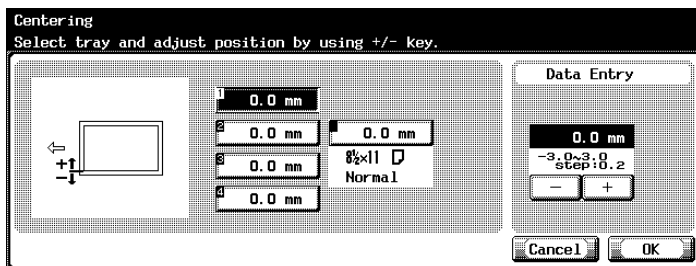

- 7 Press the [Start] key.
A test pattern is printed.

- 8 Check that the distance from the starting print position of the test pattern to the edge of the paper (b) is 3 mm (± 0.5 mm).
- If the distance is less than 2.5 mm, touch [+] to increase the adjustment (between 0.2 mm and 3.0 mm).
 - If the distance is more than 3.5 mm, touch [-] to reduce the adjustment (between -0.2 mm and -3.0 mm).
 - If the distance is between 2.5 and 3.5 mm, skip to step 10.
 - Each time [+] or [-] is touched, the value is increased or decreased by one increment.

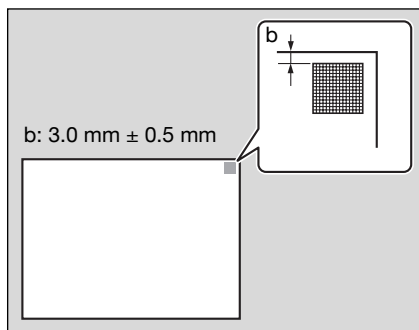

- 9 Press the [Start] key.
The adjusted test pattern is printed.
- 10 Adjust the distance from the starting print position of the test pattern to the edge of the paper.
- Check that the distance has been adjusted to between 2.5 and 3.5 mm.
 - If more adjustment is necessary, repeat steps 8 and 9.
 - To adjust the print position for a different paper tray, return to step 6.
- 11 Touch [OK].
- To cancel changes to the settings, touch [Cancel].
The print position is adjusted.

**Note**

Enter the value by mm using the keypad.

Refer to the conversion rate below.

1 in. = 25.4 mm

Adjusting the starting print position for the second side

The starting print position at the left edge of the paper for the second side during automatic double-sided copying for each paper tray can be adjusted.

- ✓ The starting print position is adjusted during manufacturing of the machine. Normally, this position will not need to be adjusted.
- ✓ Only 8-1/2 × 11  paper can be used to adjust the bypass tray.

- 1 Display the Administrator Setting screen.
 - For details on displaying the Administrator Setting screen, refer to “Displaying the Administrator Setting screen” on page 12-47.
- 2 Touch [1 System Setting].
The System Setting screen appears.
- 3 Touch [7 Expert Adjustment].
The Expert Adjustment screen appears.
- 4 Touch [2 Printer Adjustment].
The Printer Adjustment screen appears.
- 5 Touch [3 Centering (Duplex 2nd Side)].
The Centering (Duplex 2nd Side) screen appears.
- 6 Touch the button for the paper tray to be set.

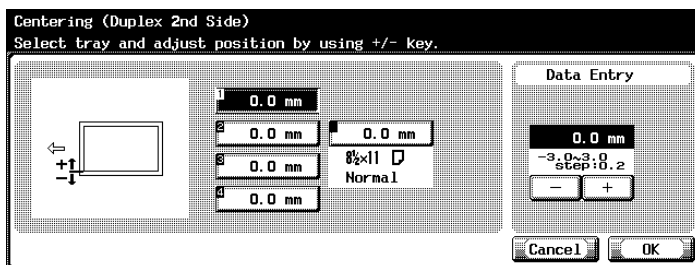

- 7 Press the [Start] key.
A test pattern is printed.

- 8 Check that the distance from the starting print position of the test pattern to the left edge of the paper (c) is 3 mm (± 0.5 mm).
- If the distance is less than 2.5 mm, touch [+] to increase the adjustment (between 0.2 mm and 3.0 mm).
 - If the distance is more than 3.5 mm, touch [-] to reduce the adjustment (between -0.2 mm and -3.0 mm).
 - If the distance is between 2.5 and 3.5 mm, skip to step 10.
 - Each time [+] or [-] is touched, the value is increased or decreased by one increment.

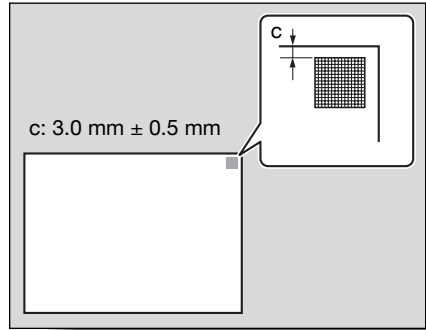

- 9 Press the [Start] key.
The adjusted test pattern is printed.
- 10 Adjust the distance from the starting print position of the test pattern to the edge of the paper.
- Check that the distance has been adjusted to between 2.5 and 3.5 mm.
 - If more adjustment is necessary, repeat steps 8 and 9.
 - To adjust the print position for a different paper tray, return to step 6.
- 11 Touch [OK].
- To cancel changes to the settings, touch [Cancel].
The print position is adjusted.



Note

Enter the value by mm using the keypad.

Refer to the conversion rate below.

1 in. = 25.4 mm

Adjusting printing according to the media

The print image can be adjusted for each type of paper that is used.

- 1 Display the Administrator Setting screen.
 - For details on displaying the Administrator Setting screen, refer to “Displaying the Administrator Setting screen” on page 12-47.
- 2 Touch [1 System Setting].
The System Setting screen appears.
- 3 Touch [7 Expert Adjustment].
The Expert Adjustment screen appears.
- 4 Touch [2 Printer Adjustment].
The Printer Adjustment screen appears.
- 5 Touch [4 Media Adjustment].
The Media Adjustment screen appears.
- 6 Touch the button for the paper type to be set.

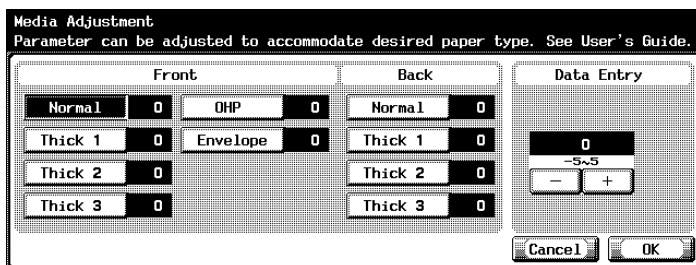

- If the image is distorted with single-sided copying, select a paper type below “Front”.
- If the image on the back side is distorted with double-sided copying, select a paper type below “Back”.

- 7** Touch [+] or [-] to adjust the setting between -5 and +5. An adjustment is possible if the size of the white areas in missing print or the white spots is 0.5 mm or less.

- For missing print or white spots in the print image, touch [-] to reduce the adjustment.

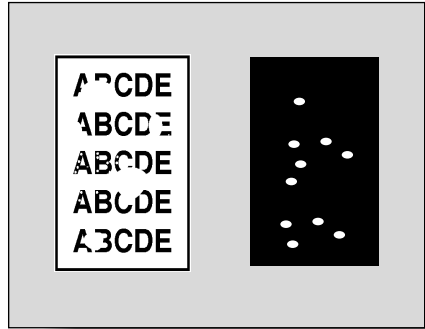

- For uneven printing of the print image, touch [+] to increase the adjustment.
- Each time [+] or [-] is touched, the value is increased or decreased by one increment.
- To cancel the adjustment, touch [Cancel].

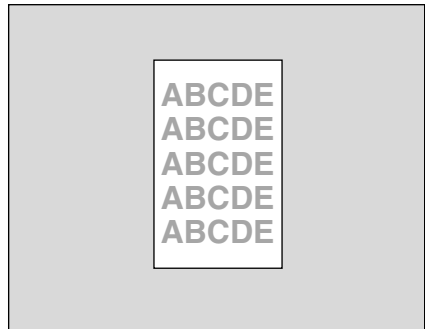

- 8** Touch [OK].

- 9** Touch [Exit].

Try performing the copy cycle again.

- 10** Check the printed image, and finish the adjustment if there are no flaws.

- If more adjustment is necessary, repeat steps 1 through 9.
- If the print image flaws are worse, adjust the setting in step 7 in the opposite direction.

12.7 Adjusting the finisher (FS-514)



Detail

For details on the “Fold & Staple” setting, refer to “To bind copies at the center (“Fold & Staple”): Finisher FS-514” on page 3-82.

For details on specifying Punch settings, refer to “Punching holes in copies (Punch settings)” on page 3-77.

Adjusting the center folding position

The folding position when printing with the “Fold” setting can be adjusted for each paper size and for each paper type.

- ✓ Before making any adjustments, use the “Fold & Staple” function to print a single sample copy. Perform the adjustment while checking the sample that was created.

- 1 Display the Administrator Setting screen.
 - For details on displaying the Administrator Setting screen, refer to “Displaying the Administrator Setting screen” on page 12-47.
- 2 Touch [1 System Setting].
The System Setting screen appears.
- 3 Touch [7 Expert Adjustment].
The Expert Adjustment screen appears.
- 4 Touch [3 Finisher Adjustment].
The Finisher Adjustment screen appears.
- 5 Touch [2 Fold Position].
The Fold Position screen appears.

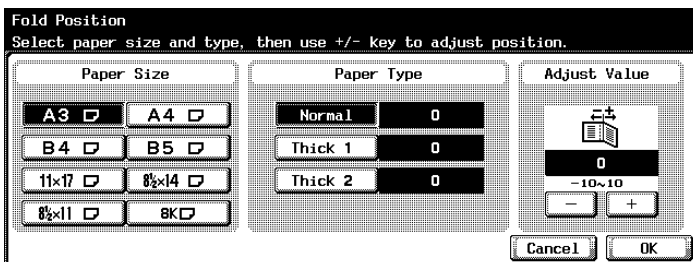

6 Touch the buttons for the paper size and paper type to be adjusted.

7 Compare the width of the left pages of the copy sample with the width of the right pages to check for the center of the paper.

- If the folding position is too far to the left of the center of the paper, touch [+] to increase the adjustment (between 1 mm and 10 mm).
- If the folding position is too far to the right of the center of the paper, touch [-] to reduce the adjustment (between -1 mm and -10 mm).
- To scroll through the values quickly, touch [+] or [-] continuously.

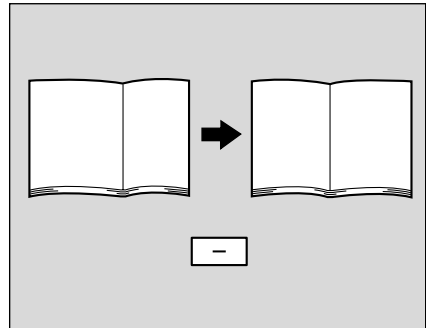
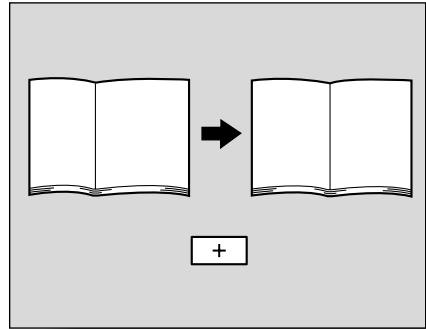

8 Touch [OK].

- To cancel changes to the settings, touch [Cancel].

The fold position is adjusted.

If the folding position was at the center of the paper in step 7, this completes the procedure.

9 Use the “Fold & Staple” function to print another sample copy.

10 Check the print result.

- Check that the folding position is adjusted to the center of the paper.
- If more adjustment is necessary, repeat steps 1 and 9.

**Note**

If the angle of the center folding position must be adjusted, contact your technical representative.

**Note**

Enter the value by mm using the keypad.

Refer to the conversion rate below.

1 in. = 25.4 mm

Adjusting the center stapling position

The stapling position when printing with the “Center Staple” setting can be adjusted for each paper size and for each paper type.

- ✓ Adjust the center folding position before adjusting the center stapling position.
- ✓ Before making any adjustments, use the “Fold & Staple” function to print a single sample copy. Perform the adjustment while checking the sample that was created.

- 1** Display the Administrator Setting screen.
 - For details on displaying the Administrator Setting screen, refer to “Displaying the Administrator Setting screen” on page 12-47.
- 2** Touch [1 System Setting].
The System Setting screen appears.
- 3** Touch [7 Expert Adjustment].
The Expert Adjustment screen appears.
- 4** Touch [3 Finisher Adjustment].
The Finisher Adjustment screen appears.

- 5 Touch [1 Center Staple Position].
The Center Staple Position screen appears.

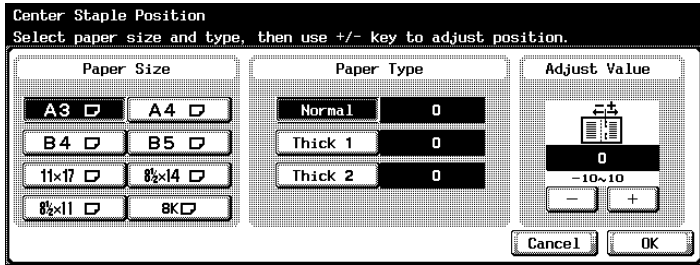

- 6 Touch the buttons for the paper size and paper type to be adjusted.

- 7 Compare the width of the left pages of the copy sample with the width of the right pages to check for the center of the paper.

- If the staple position is too far to the left of the center of the paper, touch [+] to increase the adjustment (between 1 mm and 10 mm).
- If the staple position is too far to the right of the center of the paper, touch [-] to reduce the adjustment (between -1 mm and -10 mm).
- To scroll through the values quickly, touch [+] or [-] continuously.

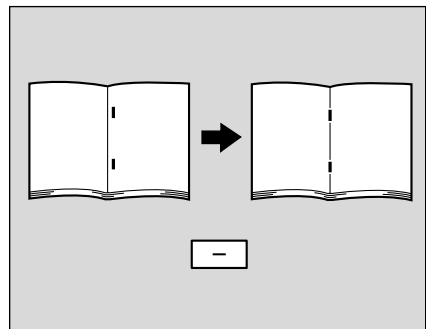
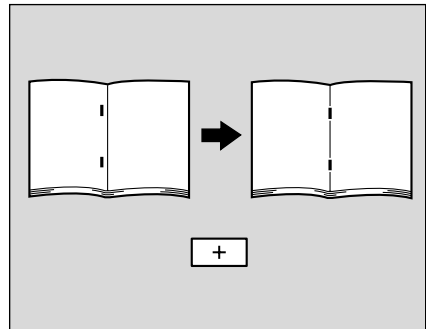

- 8 Touch [OK].
- To cancel changes to the settings, touch [Cancel].

The center stapling position is adjusted.
If the stapling position was at the center of the paper in step 7, this completes the procedure.

- 9 Use the “Fold & Staple” function to print a another sample copy.
- 10 Check the print result.
 - Check that the stapling position is adjusted to the center of the paper.
 - If more adjustment is necessary, repeat steps 1 and 9.

**Note**

If the angle of the staple must be adjusted, contact your technical representative.

For details on adjusting the center folding position, refer to “Adjusting the center folding position” on page 12-58.

**Note**

Enter the value by mm using the keypad.

Refer to the conversion rate below.

1 in. = 25.4 mm

Adjusting the horizontal punch position

The horizontal position of punched holes when printing with a Punch setting can be adjusted for each paper type.

- ✓ Before making any adjustments, use a Punch setting to print a sample copy. Perform the adjustment while checking the sample that was created.
- 1 Display the Administrator Setting screen.
 - For details on displaying the Administrator Setting screen, refer to “Displaying the Administrator Setting screen” on page 12-47.
 - 2 Touch [1 System Setting].
The System Setting screen appears.
 - 3 Touch [7 Expert Adjustment].
The Expert Adjustment screen appears.

- 4 Touch [3 Finisher Adjustment].
The Finisher Adjustment screen appears.
- 5 Touch [3 Punch Horizontal Position].
The Punch Horizontal Position screen appears.

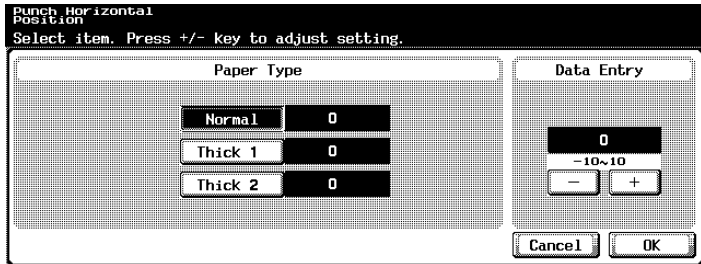

- 6 Touch the button for the paper type to be adjusted.
- 7 Check the horizontal position of the punched holes.

- To increase width A, touch [+] to increase the adjustment (between 1 mm and 10 mm).

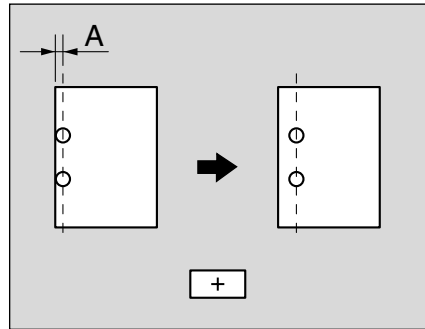

- To decrease width A, touch [-] to decrease the adjustment (between -1 mm and -10 mm).
- To scroll through the values quickly, touch [+] or [-] continuously.

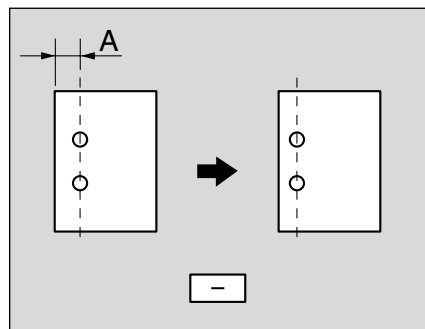

- 8 Touch [OK].
 - To cancel changes to the settings, touch [Cancel].The punch horizontal position is adjusted.
If no adjustment of the horizontal position of the punched holes was necessary in step 7, this completes the procedure.
- 9 Use the “Punch” function to print a another sample copy.
- 10 Check the print result.
 - Check that the horizontal position of the punched holes was adjusted.
 - If more adjustment is necessary, repeat steps 1 and 9.

**Note**

Enter the value by mm using the keypad.

Refer to the conversion rate below.

1 in. = 25.4 mm

Adjusting the angle of punched holes

The angle of punched holes when printing with a Punch setting can be adjusted.

- ✓ Before making any adjustments, use a Punch setting to print a sample copy. Perform the adjustment while checking the sample that was created.

- 1 Display the Administrator Setting screen.
 - For details on displaying the Administrator Setting screen, refer to “Displaying the Administrator Setting screen” on page 12-47.
- 2 Touch [1 System Setting].
The System Setting screen appears.
- 3 Touch [7 Expert Adjustment].
The Expert Adjustment screen appears.
- 4 Touch [3 Finisher Adjustment].
The Finisher Adjustment screen appears.

- 5 Touch [4 Punch Resist Loop Size].
The Punch Resist Loop Size screen appears.

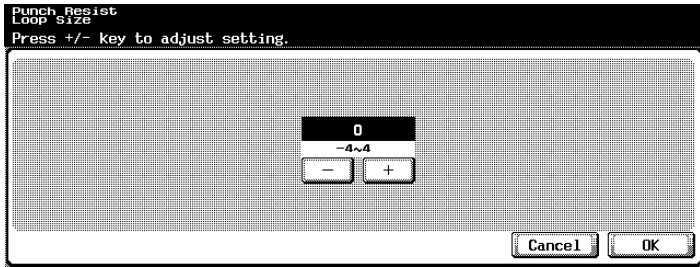

- 6 Check the angle of the punched holes.
- If the punched holes are angled, touch [+] to change the adjustment. If the angle cannot be adjusted by touching [+] or if the paper is wrinkled, touch [-] to change the adjustment.
 - To scroll through the values quickly, touch [+] or [-] continuously.
- 7 Touch [OK].
- To cancel changes to the settings, touch [Cancel].
- The angle of the punched holes is adjusted.
If no adjustment of the angle of the punched holes was necessary in step 6, this completes the procedure.
- 8 Use the “Punch” function to print a another sample copy.
- 9 Check the print result.
- Check that the angle of the punched holes was adjusted.
 - If more adjustment is necessary, repeat steps 1 and 8.

12.8 Adjusting the finisher (FS-603)



Detail

For details on the “Fold & Staple” setting, refer to “To bind copies at the center (“Fold & Staple”): Finisher FS-603” on page 3-83.

Adjusting the center stapling position

The stapling position when printing with the “Fold & Staple” function can be adjusted.

- ✓ Before making any adjustments, use the “Fold & Staple” function to print a single sample copy. Perform the adjustment while checking the sample that was created.
- 1 Display the Administrator Setting screen.
 - For details on displaying the Administrator Setting screen, refer to “Displaying the Administrator Setting screen” on page 12-47.
 - 2 Touch [1 System Setting].
The System Setting screen appears.
 - 3 Touch [7 Expert Adjustment].
The Expert Adjustment screen appears.
 - 4 Touch [3 Finisher Adjustment].
The Finisher Adjustment screen appears.
 - 5 Touch [1 Center Staple Position].
The Center Staple Position screen appears.

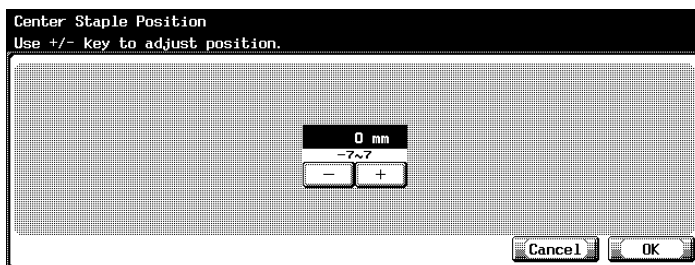

- 6 Compare the width of the left pages of the copy sample with the width of the right pages to check for the center of the paper.

- If the staple position is too far to the left of the center of the paper, touch [+] to increase the adjustment (between 1 mm and 7 mm).
- If the staple position is too far to the right of the center of the paper, touch [-] to reduce the adjustment (between -1 mm and -7 mm).
- To scroll through the values quickly, touch [+] or [-] continuously.

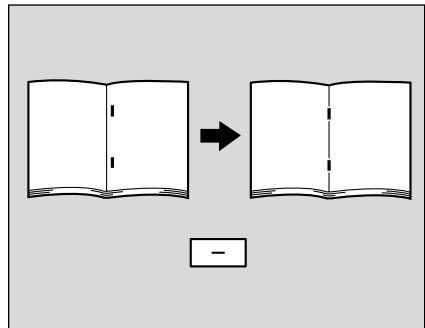
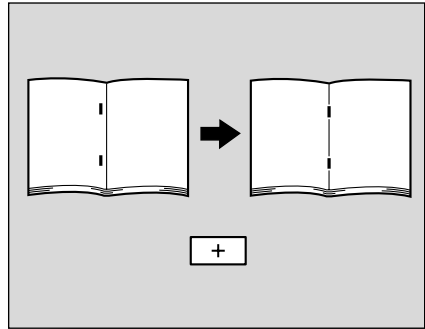

- 7 Touch [OK].

- To cancel changes to the settings, touch [Cancel].

The center stapling position is adjusted.

If the stapling position was at the center of the paper in step 6, this completes the procedure.

- 8 Use the “Fold & Staple” function to print a another sample copy.

- 9 Check the print result.

- Check that the stapling position is adjusted to the center of the paper.
- If more adjustment is necessary, repeat steps 6 and 8.

**Note**

Enter the value by mm using the keypad.

Refer to the conversion rate below.

1 in. = 25.4 mm

Adjusting the center folding position

The half-fold position when printing with the “Fold & Staple” function can be adjusted.

- ✓ Before making any adjustments, use the “Fold & Staple” function to print a single sample copy. Perform the adjustment while checking the sample that was created.
- 1 Display the Administrator Setting screen.
 - For details on displaying the Administrator Setting screen, refer to “Displaying the Administrator Setting screen” on page 12-47.
- 2 Touch [1 System Setting].
The System Setting screen appears.
- 3 Touch [7 Expert Adjustment].
The Expert Adjustment screen appears.
- 4 Touch [3 Finisher Adjustment].
The Finisher Adjustment screen appears.
- 5 Touch [2 Half-Fold Position].
The Half-Fold Position screen appears.

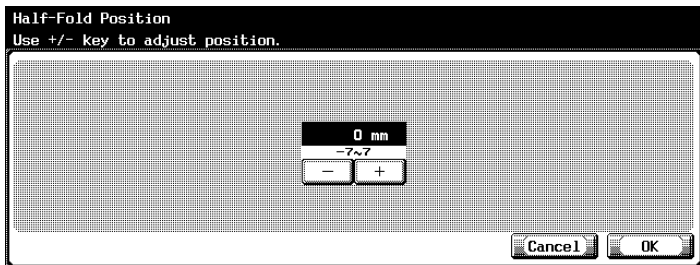

- 6** Compare the width of the left pages of the copy sample with the width of the right pages to check for the center of the paper.

- If the folding position is too far to the left of the center of the paper, touch [+] to increase the adjustment (between 1 mm and 7 mm).
- If the folding position is too far to the right of the center of the paper, touch [-] to reduce the adjustment (between -1 mm and -7 mm).
- To scroll through the values quickly, touch [+] or [-] continuously.

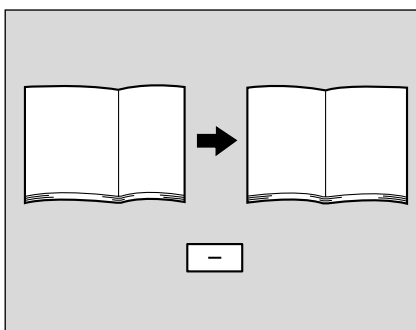
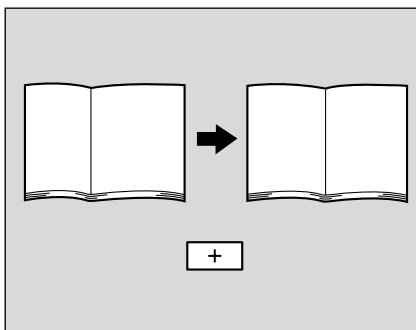

- 7** Touch [OK].

- To cancel changes to the settings, touch [Cancel].

The half-fold position is adjusted.

If the folding position was at the center of the paper in step 6, this completes the procedure.

- 8** Use the “Fold & Staple” function to print a another sample copy.

- 9** Check the print result.

- Check that the folding position is adjusted to the center of the paper.
- If more adjustment is necessary, repeat steps 6 and 8.

**Note**

Enter the value by mm using the keypad.

Refer to the conversion rate below.

1 in. = 25.4 mm

12.9 Adjusting the color registration

Adjusting the color registration for yellow, magenta and cyan

Adjust the color registration if color shifts can be seen in the print result. Color shifts can be adjusted with plain paper, thick paper 1 or thick paper 2. The procedure for adjusting the color registration is the same for yellow, magenta and cyan.

The following procedure uses 11 × 17-size paper to adjust the color registration for cyan.

- ✓ The test pattern can be printed on A3 , 11 × 17 , A4 or 8-1/2 × 11 paper that can only be loaded into the 1st tray.

- 1 Display the Administrator Setting screen.
 - For details on displaying the Administrator Setting screen, refer to “Displaying the Administrator Setting screen” on page 12-47.
- 2 Touch [1 System Setting].
The System Setting screen appears.
- 3 Touch [7 Expert Adjustment].
The Expert Adjustment screen appears.
- 4 Touch [7 Color Registration Adjust].
The Color Registration Adjust screen appears.
- 5 Touch [3 Color Registration Adjust (cyan)].
The Color Registration Adjust (cyan) screen appears.

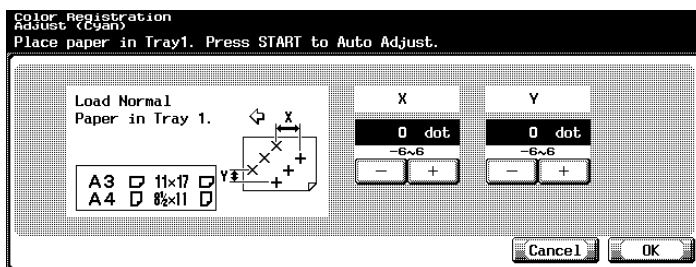

- 6 Press the [Start] key.
A test pattern is printed.
- 7 Check the distance from the reference black lines to the cyan lines in the test pattern along the X and Y directions.

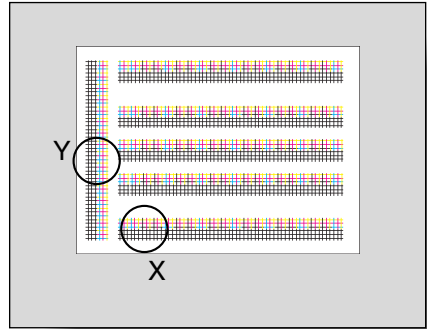

- If the lines are shifted in the X direction as shown below, touch [-] under "X" to reduce the adjustment (between -1 dot and -6 dots).

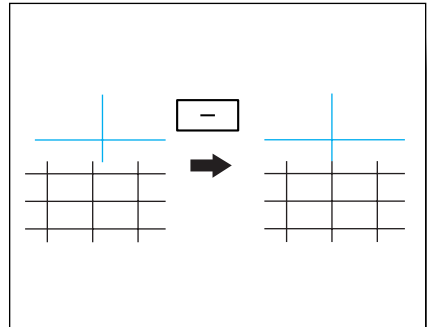

- If the lines are shifted in the X direction as shown below, touch [+] under "X" to increase the adjustment (between 1 dot and 6 dots).

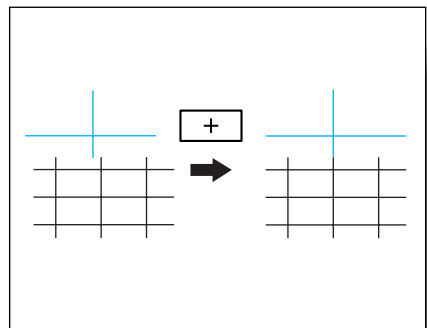

- If the lines are shifted in the Y direction as shown below, touch [-] under "Y" to reduce the adjustment (between -1 dot and -6 dots).

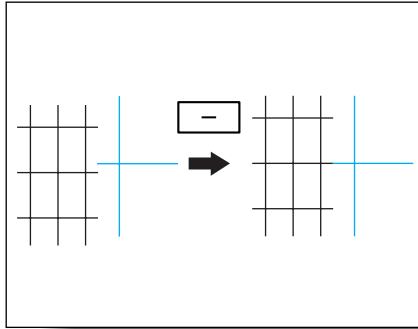

- If the lines are shifted in the Y direction as shown below, touch [+] under "Y" to increase the adjustment (between 1 dot and 6 dots).
- Each time [+] or [-] is touched, the value is increased or decreased by one increment.
- If the lines are not shifted from the reference lines, skip to step 10.

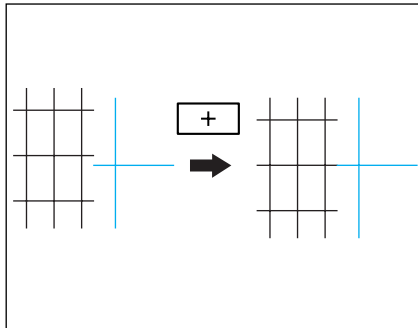

8 Press the [Start] key.

The adjusted test pattern is printed.

? When is the adjustment applied?

→ The adjustment is applied when the [Start] key is pressed. To cancel the adjustment, touch [Cancel] instead of pressing the [Start] key.

9 Check the print result.

- If there is no shift between the black and cyan lines, continue with step 10.
- If more adjustment is necessary, repeat steps 7 and 8.

10 Touch [OK].

- To cancel changes to the settings, touch [Cancel].

12.10 Adjusting the gradation levels





Adjust the gradation levels if there are changes in the color gradations of the print image.

The following color gradation adjustments can be performed.

- [Copy]: The adjustment is made with stress on increasing the number of images stored in the memory.
- [Printer (Gradation)]: The adjustment is made with stress on the gradations in images.
- [Printer (Resolution)]: The adjustment is made with stress on the reproducibility of text and lines.

The procedure for adjusting the gradation levels of the copy is described below.

Requisite

- ✓ Before adjusting the gradation levels, be sure to restart the machine. When the machine is turned off, then on again with the main power switch, wait at least 10 seconds to turn the machine on after turning it off. The machine may not operate correctly if it is turned on immediately after being turned off.
- ✓ After replacing an imaging unit, be sure to adjust the gradation levels.
- ✓ The test pattern is printed on plain paper from a paper tray loaded with one of the following sizes (listed in order of priority): A3 , 11 × 17 , A4  or 8-1/2 × 11 . Paper in the bypass tray cannot be selected.

- 1 Display the Administrator Setting screen.
 - For details on displaying the Administrator Setting screen, refer to “Displaying the Administrator Setting screen” on page 12-47.
- 2 Touch [1 System Setting].
The System Setting screen appears.
- 3 Touch [7 Expert Adjustment].
The Expert Adjustment screen appears.
- 4 Touch [8 Gradation Adjustment].
The Gradation Adjustment screen appears.

- 5 Touch the button for the mode to be adjusted.

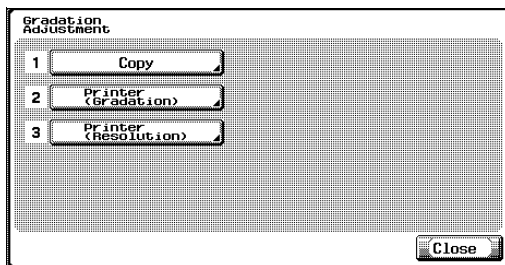

- 6 Press the [Start] key.

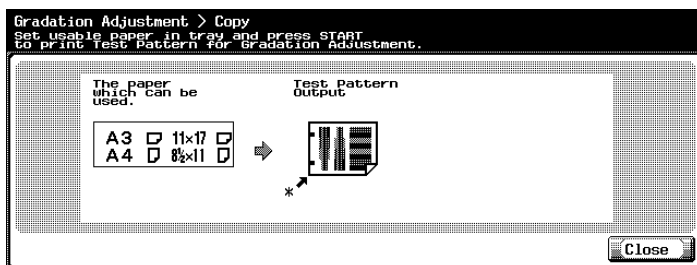

A test pattern is printed.

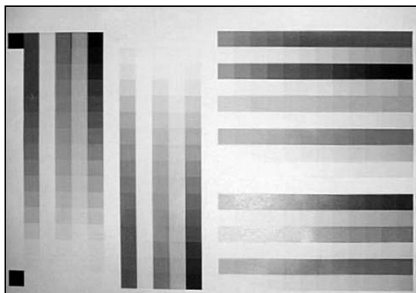

- 7 Place the printed test pattern on the original glass.
 - Be sure to load the paper in the orientation shown on the screen.

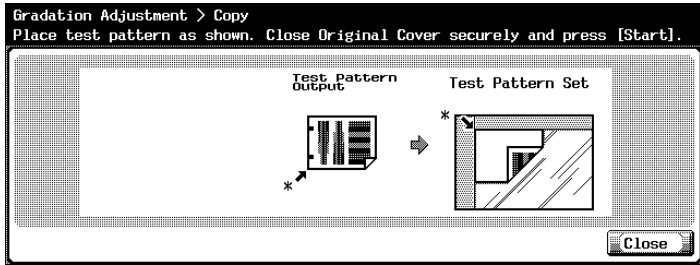

- 8 Place on top of the test pattern 10 or more sheets of blank paper of the same size as the printed test pattern page.

? Why are blank pages placed on top of the test pattern?

→ Place 10 sheets of blank paper on top of the test pattern while it is being scanned in order to prevent the document transfer belt of the ADF or the original cover pad of the original cover from being visible. If the document transfer belt or the original cover pad is visible through the pattern, the gradation levels may not be correctly adjusted.

- 9 Close the original cover, or the ADF if it is installed.

- 10 Press the [Start] key.

The printed test pattern is scanned.

When the test pattern is scanned, the gradation levels are automatically adjusted based on the scanned image.

- 11 Repeat steps 6 through 10 three times.

- 12 Touch [Close].

12.11 Authentication method

User authentication and account track settings can be specified to limit the use of this machine. User authentication settings are specified to manage individuals, and account track settings are specified to manage groups and multiple users.

By specifying both user authentication and account track settings, the number of prints made by each group can be managed for each individual user.



Note

A total of 1,000 users and accounts can be registered on this machine.

If an authentication mode is set, the authentication screen is displayed while this machine is in standby. In order to use this machine when user authentication or account track settings are specified, the user name and password must be entered. For details, refer to "Controlling each user's use of this machine (user authentication)" on page 2-40.

User authentication and account track

User authentication and account track can be used to specify the following settings.

- User authentication
 - Limits on the available functions (copy operations, scanning operations, fax operations and printing)
 - Counters for printing/scanning by each user
 - Limits on using color or black printing and on the number of copies that can be set
 - Management of personal boxes by each owner
 - Delete and restrict jobs of other users
- Account track
 - Counters for printing/scanning from each account
 - Limits on using color or black printing and on the number of copies that can be set

When user authentication and account track are synchronized

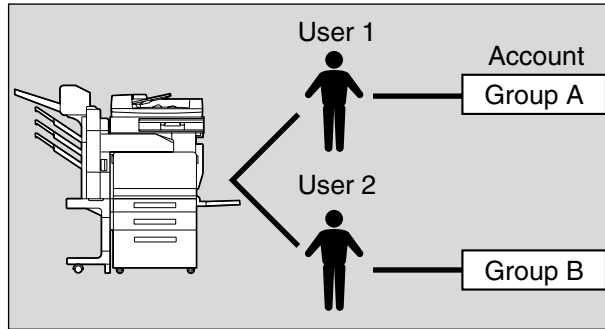

This setup is used when the machine is used by multiple departments and the use by each employee is managed by each department. With this setup, totals can be maintained on each employee (each user) and on each department (each account).

To manage the use of this machine in this way, specify the following authentication settings.

Parameter on General Settings Screen	Settings
User Authentication	Select "ON (External Server)" or "ON (MFP)".
Account Track	Select "ON", and then specify the account name and password.
Synchronize User Authentication & Account Track	Select "Synchronize".
Account Name (on User Registration screen)	Select an account name if "ON (MFP)" was selected.



Note

The account track and user authentication settings can be specified separately. Check the differences between these features, and then specify the appropriate settings.

For details on external server authentication, refer to the User's Guide [Network Scanner Operations].

When user authentication and account track are used separately

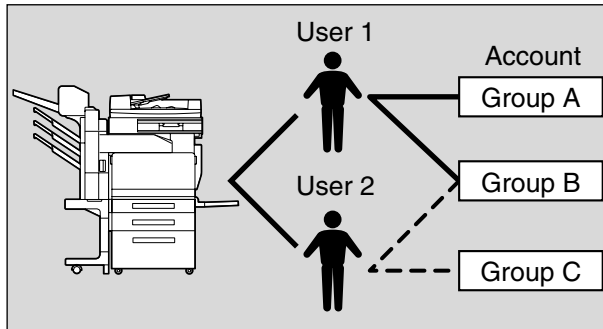

This setup is used when the machine is used by multiple employees with each employee performing multiple duties, which are to be totaled separately. With this setup, totals can be maintained on each employee (each user) and on each duty of the employee (each account). In addition, totals can be maintained on each employee (each user) and each duty (each account) even if the same duty is performed by two different employees.

To manage the use of this machine in this way, specify the following authentication settings.

Parameter on General Settings Screen	Settings
User Authentication	Select "ON (External Server)" or "ON (MFP)".
Account Track	Select "ON", and then specify the account name and password.
Synchronize User Authentication & Account Track	Select "Do Not Synchronize".

To select an authentication method

- 1 Display the Administrator Setting screen.
 - For details on displaying the Administrator Setting screen, refer to “Displaying the Administrator Setting screen” on page 12-47.
- 2 Touch [4 User Authentication/Account Track].
The User Authentication/Account Track screen appears.
- 3 Touch [1 General Settings].
The General Settings screen appears.
- 4 Beside “User Authentication”, touch the button for the desired setting.
 - To cancel user authentication, touch [OFF].
 - To use the user authentication function from an external server, touch [ON (External Server)], and then select the server type.
 - To use the user authentication function of this machine, touch [ON (MFP)].

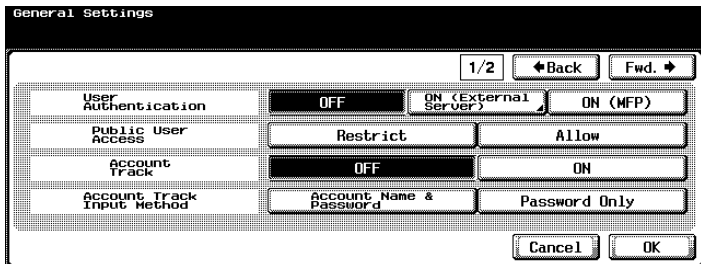

- 5 Beside “Public User Access”, touch the button for the desired setting.
 - To prohibit unregistered users from using this machine, touch [Restrict].
 - To allow this machine to be used when a user name or password is not entered even though user authentication settings have been applied, touch [Allow].
- 6 Beside “Account Track”, touch the button for the desired setting.
 - To cancel account tracking, touch [OFF].
 - To use the account track function, touch [ON].

- 7 Beside “Account Track Input Method”, touch the button for the desired setting.
 - To allow this machine to be used after the account name and password are entered in the account track screen, touch [Account Name & Password].
 - To allow this machine to be used after the password is entered in the account track screen, touch [Password Only].
- 8 Touch [Fwd.→].
The second screen is displayed.
- 9 Beside “When # of Jobs Reach Maximum”, touch the button for the desired setting.
 - To skip the job when the limit specified with account track is reached, touch [Skip Job].
 - To stop the machine when the limit specified with account track is reached, touch [Stop Job].

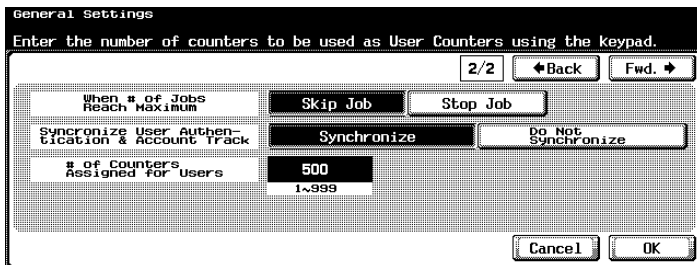

- 10 Beside “Synchronize User Authentication & Account Track”, touch the button for the desired setting.
 - Synchronize:
If “ON (MFP)” is set and “Account Track” is set to “ON”, this setting allows this machine to be used simply by entering user authentication information the first time that the machine is used if the corresponding account was specified during user registration.
If “ON (External Server)” is set and “Account Track” is set to “ON”, this setting allows the machine to be used simply by entering user authentication information after the machine has been used once with the appropriate user authentication and account track information entered.
 - Do Not Synchronize:
This setting requires that all information be entered for user authentication and account track each time that the machine is used.

- 11 Beside “# of Counters Assigned for Users”, specify the desired setting.
 - Press the [C] (clear) key to erase the value, and then use the keypad to specify the desired value (between 1 and 999).
 - If user authentication and account track settings have been applied, counters can be assigned to both accounts and users, and counts for both can be totaled.
- 12 Touch [OK].
 - If the setting for “User Authentication” or “Account Track” was changed, the message “Are you sure you want to clear all data?” appears.
- 13 Touch [Yes].

The authentication method is set.
Continue by specifying settings for user authentication and account track.



...

Reminder

Do not differentiate between uppercase and lowercase letters in the user name for the external server. Since the C252 cannot differentiate between uppercase and lowercase letters, the operation may not be performed correctly.



...

Note

“Synchronize User Authentication & Account Track” appears if “User Authentication” is set to “ON (External Server)” or “ON (MFP)” and “Account Track” is set to “ON”.

If “Synchronize User Authentication & Account Track” is set to “Synchronize”, even when “Public User Access” is set to “Allow”, “Public User Access” changes to “Restrict”.

**Detail**

For details on external server authentication, refer to the User's Guide [Network Scanner Operations].

If both user authentication and account track settings have been applied, "Account Track Input Method" is set to "Account Name & Password".

A public user can be set to provide temporary access to this machine. If public user access is permitted, we recommend placing limitation on the machine functions that can be used. For details, refer to "User registration" on page 12-90.

If account track settings have been applied while "User Authentication" is set to "ON (External Server)", type in the user name and password in the user authentication screen, and then type in the account name and password in the account track screen.

If "ON (MFP)" is set and "Account Track" is set to "ON", but the corresponding account was not specified when the user was registered, user authentication and account track information must be entered each time that the machine is used, even if "Synchronize User Authentication & Account Track" has been set to "Synchronize".

If "Synchronize User Authentication & Account Track" was set to "Do Not Synchronize", use by a public user is not permitted.

**Note**

"# of User Counters" appears if "User Authentication" is set to "ON (External Server)" or "ON (MFP)" and "Account Track" is set to "ON".

If the number of user counters is set to "50", up to 950 accounts can be registered.

If [No] was touched, the management data is not cleared; however, the settings cannot be changed.

If the setting for any of the following is changed, the data is not cleared. "Public User Access", "When # of Jobs Reach Maximum", or "Synchronize User Authentication & Account Track"

To cancel changes to the settings, touch [Cancel].

12.12 User authentication setting

User authentication settings can be specified.

Administrative setting—user name list

User authentication settings can be specified to display [List] in the user authentication screen and the User Name screen. Touch [List] to display a list of registered user names from which the desired user name can simply be selected. (The default setting is “OFF”.)

- 1 Display the Administrator Setting screen.
 - For details on displaying the Administrator Setting screen, refer to “Displaying the Administrator Setting screen” on page 12-47.
- 2 Touch [4 User Authentication/Account Track].
The User Authentication/Account Track screen appears.
- 3 Touch [2 User Authentication Setting].
The User Authentication Setting screen appears.
 - ? Can [2 User Authentication Setting] be selected?
 - [2 User Authentication Setting] is not available if “User Authentication” on the General Settings screen is set to “OFF”.
- 4 Touch [1 Administrative Setting].
- 5 Touch [User Name List].

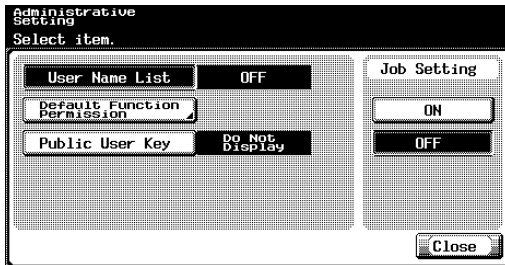

Buttons for the available settings appear.

- 6 Touch the button for the desired setting.
Whether a user name list button appears or not is set.

**Note**

To limit machine use by authorized users, specify settings in the User Registration screen.

Default function permission

If external server authentication was selected, limitations can be placed on the machine functions that can be used by an authorized user. (The default setting is “Allow”.)

The following operations can be limited.

- Copy operations
- Scan operations
- Fax operations
- Printing operations
- Saving documents on the hard disk
- Printing transmission functions

To specify the default function permissions

- 1** Display the Administrator Setting screen.
 - For details on displaying the Administrator Setting screen, refer to “Displaying the Administrator Setting screen” on page 12-47.
- 2** Touch [4 User Authentication/Account Track].
The User Authentication/Account Track screen appears.
- 3** Touch [2 User Authentication Setting].
The User Authentication Setting screen appears.
 - ? Can [2 User Authentication Setting] be selected?
 - [2 User Authentication Setting] is not available if “User Authentication” on the General Settings screen is set to “OFF”.
- 4** Touch [1 Administrative Setting].
- 5** Touch [Default Function Permission].
The Default Function Permission screen appears.

- 6 Touch the buttons for the desired settings.

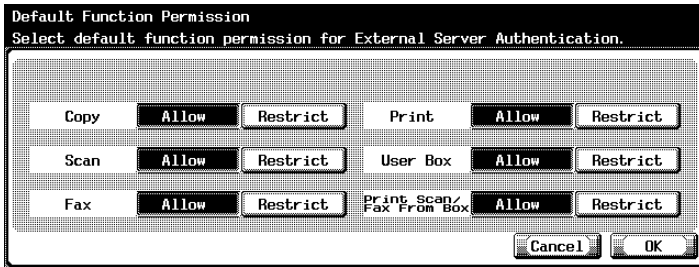

- 7 Touch [OK].

The default function permissions are set.



Note

To limit machine use by authorized users, specify settings in the User Registration screen.

If "Print Scan / Fax From Box" setting is used to scan or fax a document saved in a box, printing of the document can be prevented.

Authenticating public users

If user authentication settings have been specified and public user access is permitted, the authentication screen does not appear when logging on if "Public User Key" is set to "Do Not Display". (The default setting is "Do Not Display".)

- 1 Display the Administrator Setting screen.
 - For details on displaying the Administrator Setting screen, refer to "Displaying the Administrator Setting screen" on page 12-47.
- 2 Touch [4 User Authentication/Account Track].
The User Authentication/Account Track screen appears.
- 3 Touch [2 User Authentication Setting].
The User Authentication Setting screen appears.
 - ? Can [2 User Authentication Setting] be selected?
 - [2 User Authentication Setting] is not available if "User Authentication" on the General Settings screen is set to "OFF".
- 4 Touch [1 Administrative Setting].

- 5 Touch [Public User Key].
Buttons for the available settings appear.
- 6 Touch the button for the desired setting.
The machine is set to display [Public User Access].

User registration

The password, printing permissions, number of prints allowed, and function permissions can be specified for each user of this machine.

As an example, the following procedure describes how to register a user with authentication performed by the machine.

- ✓ A total of 1,000 users and accounts can be registered on this machine.
- ✓ If “Public User Access” on the General Settings screen is set to “Allow”, a public user is added.
- ✓ If “Account Track” on the General Settings screen is set to “ON”, the number of users set for “# of User Counters” can be registered.

- 1 Display the Administrator Setting screen.
 - For details on displaying the Administrator Setting screen, refer to “Displaying the Administrator Setting screen” on page 12-47.

- 2 Touch [4 User Authentication/Account Track].
The User Authentication/Account Track screen appears.

- 3 Touch [2 User Authentication Setting].
The User Authentication Setting screen appears.

? Can [2 User Authentication Setting] be selected?

→ [2 User Authentication Setting] is not available if “User Authentication” on the General Settings screen is set to “OFF”.

- 4 Touch [2 User Registration].
- 5 Touch the button for the desired user.
The User Registration screen appears.

- 6 Touch [User Name].

The screenshot shows a 'User Registration' dialog box with the following elements:

- Title: User Registration
- Instruction: Select item to register/edit.
- Fields:
 - User Name (with a dropdown arrow)
 - Account Name (with a dropdown arrow)
 - User Password (with a dropdown arrow)
 - Output Permission (with a dropdown arrow)
 - E-Mail Address (with a dropdown arrow)
 - Max. Allowance Set (with a dropdown arrow)
- Buttons at the bottom:
 - Function Permission (with a dropdown arrow)
 - Delete
 - Cancel
 - OK

The User Name screen appears.

- 7 Type in the user name (up to 64 characters), and then touch [OK].
 - For details on typing in text, refer to “Entering text” on page 13-2.
 - Once a user name is registered, it cannot be changed.
 - A user name that has already been registered cannot be used again.

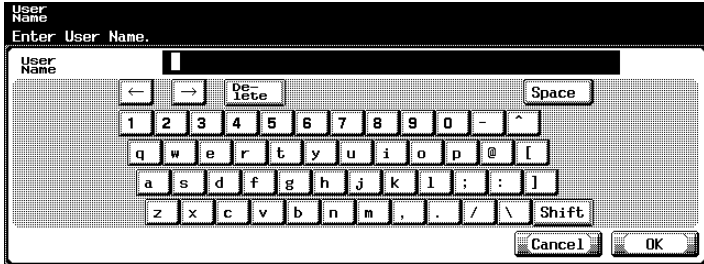

The user name is set.

- 8 Touch [User Password].
 - If “Account Track Input Method” was set to “Password Only”, the same password cannot be registered more than once.

The Password screen appears.

? Can [User Password] be selected?

→ [User Password] is not available if “User Authentication” on the General Settings screen is set to “ON (External Server)”.

- 9 Type in the password (up to 64 characters), and then touch [OK].
A screen for retyping the password appears.

- 10 Retype the password specified in step 9, and then touch [OK].
The user password is set.

- 11 Touch [E-Mail Address].
The E-Mail Address screen appears.

- 12 Type in the e-mail address (up to 320 characters), and then touch [OK].
The e-mail address is set.
If the e-mail address exceeds 116 characters, [Details] appears in the User Registration screen. Touch [Details] to display the E-Mail Address Details screen and the entire e-mail address.

- 13 Touch [Account Name].
The Account Name screen appears.

- 14 Touch the button for the desired account, and then touch [OK].
The account is set.
 - Before an account name can be selected, accounts must have been registered. For details on registering accounts, refer to “Account track registration” on page 12-98.
- 15 Touch [Output Permission].
The Output Permission screen appears.
- 16 Beside “Print” and “Send”, touch the button for the desired settings.
 - To permit the user to output, touch [Allow].
 - To prohibit the user to output, touch [Restrict].
 - Touch [All Users] to apply the settings in the current screen to all registered users. Touch [All Users], and then touch [OK] in the two screens that appear to display a message and apply the settings to all users. At this time, do not turn off the machine with the main power switch.

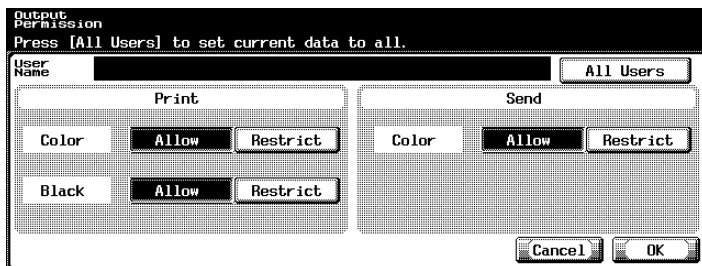

- If “Color” of the “Print” is set to “Restrict”, printing is not possible with the “Full Color”, “2 Color” or “Single Color” settings.
 - If “Black” of the “Print” is set to “Restrict”, printing is not possible with the “Black” setting.
 - If both “Color” and “Black” of the “Print” are set to “Restrict”, the message “Copying is restricted.” appears if authentication was completed correctly.
 - If “Color” is set to “Restrict” under “Send”, color scanning is not possible.
- 17 Touch [OK].
The output permissions are set.
 - 18 Touch [Max. Allowance Set].
The Max. Allowance Set screen appears.

- 19** Touch [Total Allowance] or [Individual Allowance].
- To specify the maximum number of combined color and black prints allowed, touch [Total Allowance].
 - To separately specify the maximum number of color and black prints allowed, touch [Individual Allowance].

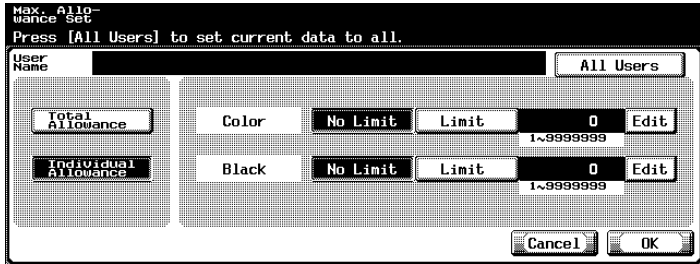

- 20** Touch [No Limit] or [Limit].

- 21** Using the keypad, type in the maximum number allowed.

- If “Individual Allowance” was selected, touch [Edit] beside the print mode set to “Limit”, and then use the keypad to type in the maximum number allowed.
- Touch [All Users] to apply the settings in the current screen to all registered users. Touch [All Users], and then touch [OK] in the two screens that appear to display a message and apply the settings to all users. At this time, do not turn off the machine with the main power switch.

- 22** Touch [OK].

The maximum number of prints allowed are set.

- 23** Touch [Function Permission].

The Function Permission screen appears.

- 24** Touch the button for the desired setting for each operation.
- To permit the operation to be performed, touch [Allow].
 - To prohibit the operation to be performed, touch [Restrict].
 - Touch [All Users] to apply the settings in the current screen to all registered users. Touch [All Users], and then touch [OK] in the two screens that appear to display a message and apply the settings to all users. At this time, do not turn off the machine with the main power switch.

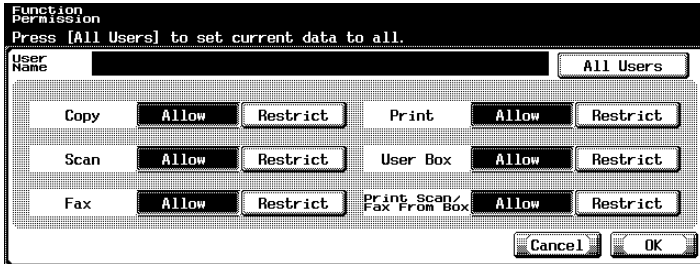

- If "Print Scan / Fax From Box" setting is used to scan or fax a document saved in a box, printing of the document can be prevented.
- Depending on the function limitation settings that are specified, a different Basic screen may appear when logging on. The Basic screen that appears changes in the following order: Copy → Scan → Fax → Box.
- If no operation is permitted, user authentication cannot be performed.

- 25** Touch [OK].
The function permissions are set.

- 26** Touch [OK].
- To erase the current user, touch [Cancel].
 - To delete the selected user information, touch [Delete].

User counter

This function is used to check the following data for each user.

Copy + Print

This count shows the total number of copies and printouts made.

- **Total:** Shows the total number of copies and printouts made using all Color settings, the “Black” setting, the “Full Color” setting, the “2 Color” setting and the “Single Color” setting
- **Max Allowance:** Shows the limits set for the user for the number of copies and printouts that can be made using all Color settings (Total), the color settings (Full Color, Single Color, and 2 Color) and the “Black” setting
- **Large Size:** Shows the total number of copies and printouts made on paper specified as large-size paper using all Color settings, the “Black” setting, the “Full Color” setting, the “2 Color” setting and the “Single Color” setting

Copy

This count shows the total number of copies made.

- **Total:** Shows the total number of copies made using all Color settings, the “Black” setting, the “Full Color” setting, the “2 Color” setting and the “Single Color” setting
- **Large Size:** Shows the total number of copies made on paper specified as large-size paper using all Color settings, the “Black” setting, the “Full Color” setting, the “2 Color” setting and the “Single Color” setting

Print

This count shows the total number of printouts made.

- **Total:** Shows the total number of printouts made using all Color settings, the “Black” setting, the “Full Color” setting, and the “2 Color” setting
- **Large Size:** Shows the total number of printouts made on paper specified as large-size paper using all Color settings, the “Black” setting, the “Full Color” setting, and the “2 Color” setting

Scan/Fax

- **Total:** Shows the total number of pages scanned/total number of black and color prints in the Scan and Fax modes
- **Large Size:** Shows the total number of pages scanned/total number of black and color prints in the Scan and Fax modes for paper specified as large-size paper
- **Fax TX:** Shows the total number of pages transmitted in Fax mode

Original Counter

- Shows the number of document pages that were scanned

Paper Counter

- Shows the number of pages used for printing

**Note**

Counting automatically continues with user counters for external server authentication.

If “Public User Access” on the General Settings screen was set to “Allow”, “public” is added to the list of counters.

If “User Box Admin.” was set to “Allow”, “Box Admin” is added to the list of counters.

To check the counter

- 1 Display the Administrator Setting screen.
 - For details on displaying the Administrator Setting screen, refer to “Displaying the Administrator Setting screen” on page 12-47.
- 2 Touch [4 User Authentication/Account Track].
The User Authentication/Account Track screen appears.
- 3 Touch [2 User Authentication Setting].
The User Authentication Setting screen appears.
 - ? Can [2 User Authentication Setting] be selected?
 - [2 User Authentication Setting] is not available if “User Authentication” on the General Settings screen is set to “OFF”.
- 4 Touch [3 User Counter].
- 5 Touch the button for the desired user.
The User Counter screen for the selected user appears.
- 6 Touch the button for the counter to be viewed, and then check the counter.

User Counter

User Name: 123abc Clear Counter

	Total	Black	Full Color	2 Color	Single Color
Total	20	5	5	5	5
Max Allowance	0	10000	10000		
Large Size	0	0	0	0	0

Original Counter: 20 Paper Counter: 20

Close

- To clear the counters for the current user, touch [Clear Counter] in the User Counter screen for the current user. A confirmation message appears, asking whether the counter should be cleared. To clear the counters for the current user, touch [Yes]. The maximum number allowed is not cleared.
- To clear the counters for all users, touch [Reset All Counters] in the User Counter screen containing a list of all users. A confirmation message appears, asking whether the counters should be cleared. To clear the counters for all users, touch [Yes]. The maximum number allowed is not cleared.

7 Touch [Close].

12.13 Account track setting



Note

A total of 1,000 users and accounts can be registered on this machine.

Account track registration

The password, printing permissions, and number of prints allowed can be specified for each account using this machine.

The following procedure describes how to specify accounts when “Account Track Input Method” on the General Settings screen is set to “Account Name & Password”.

- 1 Display the Administrator Setting screen.
 - For details on displaying the Administrator Setting screen, refer to “Displaying the Administrator Setting screen” on page 12-47.
- 2 Touch [4 User Authentication/Account Track].
The User Authentication/Account Track screen appears.
- 3 Touch [3 Account Track Setting].
The Account Track Setting screen appears.
- 4 Touch [1 Account Track Registration].

- 5 Touch the button for the desired account.

The Account Track Registration screen appears.

If “Account Name & Password” was selected:

The screenshot shows the 'Account Track Registration' screen with the title 'Select item to register/edit.'. On the left, there are two input fields: 'Account Name' and 'Password', both containing blacked-out text. On the right, there are two buttons: 'Output Permission' and 'Max. Allowance Set'. At the bottom left is a 'De-lete' button, and at the bottom right are 'Cancel' and 'OK' buttons.

If “Password Only” was selected:

The screenshot shows the 'Account Track Registration' screen with the title 'Select item to register/edit.'. On the left, there are two input fields: 'Password' and 'Name', both containing blacked-out text. On the right, there are two buttons: 'Output Permission' and 'Max. Allowance Set'. At the bottom left is a 'De-lete' button, and at the bottom right are 'Cancel' and 'OK' buttons.

- 6 Touch [Account Name].

The Account Name screen appears.

- 7 Type in the account name (up to 8 characters), and then touch [OK].
- For details on typing in text, refer to “Entering text” on page 13-2.
 - If [Name] was displayed, type in the account name (up to 20 characters), and then touch [OK].
 - If “Account Name & Password” was selected, the same account name cannot be used more than once.

The screenshot shows the 'Account Name' screen with the title 'Enter Account Name.'. At the top, there is an input field for the account name. Below it is a full QWERTY keyboard with a 'De-lete' button above the spacebar. At the bottom right are 'Cancel' and 'OK' buttons.

The account name is set.

- 8 Touch [Password].
 - If “Account Track Input Method” was set to “Password Only”, the same password cannot be registered more than once.
 The Password screen appears.
- 9 Type in the password (up to 8 characters), and then touch [OK].
A screen for retyping the password appears.
- 10 Retype the password specified in step 9, and then touch [OK].
The account password is set.
- 11 Touch [Output Permission].
The Output Permission screen appears.
- 12 Beside “Print” and “Send”, touch the button for the desired settings.
 - To permit outputting by the account, touch [Allow].
 - To prohibit outputting by the account, touch [Restrict].
 - Touch [All Accounts] to apply the settings in the current screen to all registered accounts. Touch [All Accounts], and then touch [OK] in the two screens that appear to display a message and apply the settings to all accounts. At this time, do not turn off the machine with the main power switch.

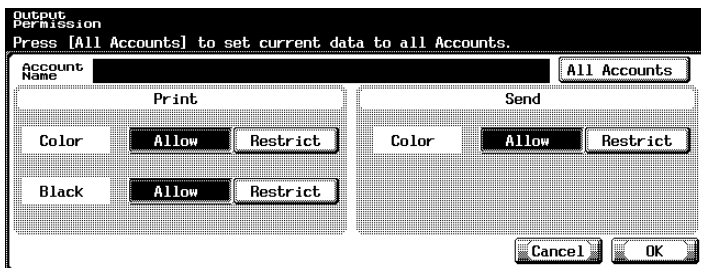

- If “Color” of the “Print” is set to “Restrict”, printing is not possible with the “Full Color”, “2 Color” or “Single Color” settings.
- If “Black” of the “Print” is set to “Restrict”, printing is not possible with the “Black” setting.
- If both “Color” and “Black” of the “Print” are set to “Restrict”, the message “Copying is restricted.” appears if authentication was completed correctly.
- If “Color” is set to “Restrict” under “Send”, color scanning is not possible.

- 13 Touch [OK].
The output permissions are set.
- 14 Touch [Max. Allowance Set].
The Max. Allowance Set screen appears.
- 15 Touch [Total Allowance] or [Individual Allowance].
 - To specify the maximum number of combined color and black prints allowed, touch [Total Allowance].
 - To separately specify the maximum number of color and black prints allowed, touch [Individual Allowance].

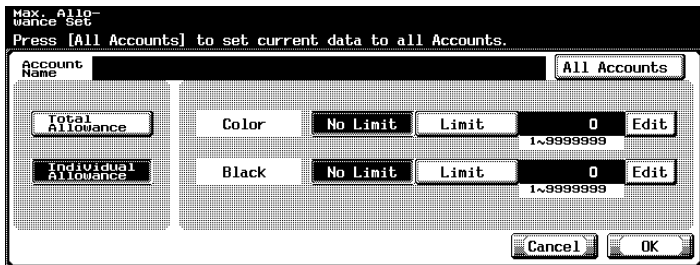

- 16 Touch [No Limit] or [Limit].
- 17 Using the keypad, type in the maximum number allowed.
 - If “Individual Allowance” was selected, touch [Edit] beside the print mode set to “Limit”, and then use the keypad to type in the maximum number allowed.
 - Touch [All Accounts] to apply the current settings to all other registered accounts. Touch [All Accounts], and then touch [OK] in the next two screens that appear to apply the settings in the current screen to all accounts. At this time, do not turn off the machine with the main power switch.
- 18 Touch [OK].
The maximum number of prints allowed is set.
- 19 Touch [OK].
 - To erase the current account, touch [Cancel].
 - To delete the selected account information, touch [Delete].

Account track counter

This function is used to check the following data for each account.

Copy + Print

This count shows the total number of copies and printouts made.

- Total: Shows the total number of copies and printouts made using all Color settings, the “Black” setting, the “Full Color” setting, the “2 Color” setting and the “Single Color” setting
- Max Allowance: Shows the limits set for the account for the number of copies and printouts that can be made using all Color settings (Total), the color settings (Full Color, Single Color, and 2 Color) and the “Black” setting
- Large Size: Shows the total number of copies and printouts made on paper specified as large-size paper using all Color settings, the “Black” setting, the “Full Color” setting, the “2 Color” setting and the “Single Color” setting

Copy

This count shows the total number of copies made.

- Total: Shows the total number of copies made using all Color settings, the “Black” setting, the “Full Color” setting, the “2 Color” setting and the “Single Color” setting
- Large Size: Shows the total number of copies made on paper specified as large-size paper using all Color settings, the “Black” setting, the “Full Color” setting, the “2 Color” setting and the “Single Color” setting

Print

This count shows the total number of printouts made.

- Total: Shows the total number of printouts made using all Color settings, the “Black” setting, the “Full Color” setting, and the “2 Color” setting
- Large Size: Shows the total number of printouts made on paper specified as large-size paper using all Color settings, the “Black” setting, the “Full Color” setting, and the “2 Color” setting

Scan/Fax

- Total: Shows the total number of pages scanned/total number of black and color prints in the Scan and Fax modes
- Large Size: Shows the total number of pages scanned/total number of black and color prints in the Scan and Fax modes for paper specified as large-size paper
- Fax TX: Shows the total number of pages transmitted in Fax mode

Original Counter

- Shows the number of document pages that were scanned

Paper Counter

- Shows the number of pages used for printing

**Note**

If “User Box Admin.” was set to “Allow” and only account track settings have been specified, “Box Admin” appears at the end of the list of counters.

To check the counter

- 1** Display the Administrator Setting screen.
 - For details on displaying the Administrator Setting screen, refer to “Displaying the Administrator Setting screen” on page 12-47.
- 2** Touch [4 User Authentication/Account Track].
The User Authentication/Account Track screen appears.
- 3** Touch [3 Account Track Setting].
The Account Track Setting screen appears.
- 4** Touch [2 Account Track Counter].
- 5** Touch the button for the desired account.
The Account Track Counter screen for the selected account appears.
- 6** Touch the button for the counter to be viewed, and then check the counter.
 - To clear the counters for the current account, touch [Clear Counter] in the Account Track Counter screen for the current account. A confirmation message appears, asking whether the counter should be cleared. To clear the counters for the current account, touch [Yes]. The maximum number allowed is not cleared.

- To clear the counters for all accounts, touch [Reset All Counters] in the Account Track Counter screen containing a list of all accounts. A confirmation message appears, asking whether the counters should be cleared. To clear the counters for all accounts, touch [Yes]. The maximum number allowed is not cleared.

Account Track Counter

Account Name: **123abc** Clear Counter

<input type="button" value="Copy + Print"/> <input type="button" value="Copy"/> <input type="button" value="Print"/> <input type="button" value="Scan/Fax"/>		Total	Black	Full color	2 Color	Single Color
	Total	20	5	5	5	5
	Max Allowance	0	10000	10000		
	Large Size	0	0	0	0	0
Original Counter		20		Paper Counter		20

- 7 Touch [Close].

12.14 Password rules

If password rules are applied and already specified passwords do not meet the password rules, those passwords are not accepted when they are entered. In that case, the administrator should temporarily turn off the password rules, then specify the passwords according to the following conditions.

Conditions of the password rules

Administrator Password

Limitations on the number of characters	Limitations on registering/changing
8 alphanumeric characters (case-sensitive)	<ul style="list-style-type: none"> • A password that consists of a repetition of the same character cannot be registered. • The same password as one before being changed cannot be registered.

User Password /Account Password

Limitations on the number of characters	Limitations on registering/changing
8 or more alphanumeric characters (case-sensitive)	<ul style="list-style-type: none"> • A password that consists of a repetition of the same character cannot be registered. • The same password as one before being changed cannot be registered.

User Box Password

Limitations on the number of characters	Limitations on registering/changing
8 alphanumeric characters (case-sensitive)	<ul style="list-style-type: none"> • A password that consists of a repetition of the same character cannot be registered. • The same password as one before being changed cannot be registered.

Password for the confidential document

Limitations on the number of characters	Limitations on registering/changing
8 alphanumeric characters (case-sensitive)	A password that consists of a repetition of the same character cannot be registered.

**Note**

Use the administrator password when specifying settings on the Administrative Setting screen.

Use the user password/account password when user authentication/account track settings have been applied.

For details on the “User Box Password” and “Password for the confidential document”, refer to the Box Operations of the User’s Guide.

*Specify 8 characters (numbers, * or #) as the fax transmission password for boxes.*

12.15 Enhanced security settings

When enhanced security setting is applied on this machine, various security settings are also changed in order to increase security when managing scan data. Restrictions are applied to user operations, public user access is prohibited, and box operations and print jobs are limited.

There are various settings that must first be specified or are forcibly set in order for “Enhanced Security Mode” to be set to “ON”. Before setting “Enhanced Security Mode” to “ON”, be sure to check the settings for the security functions.



Reminder

If there are settings that are incompatible with the enhanced security settings, “Enhanced Security Mode” cannot be set to “ON”.



Detail

Certain conditions must be met in order for the enhanced security settings to be applied. For details, contact your technical representative.

The settings that must be specified or are forcibly set when “Enhanced Security Mode” is set to “ON” cannot be changed.

Required settings

The following settings must first be specified in order to set “Enhanced Security Mode” to “ON”.

Administrator Setting commands	Settings
User Authentication/Account Track—General Settings—User Authentication	Select “ON (External Server)” or “ON (MFP)”.
System Connection—OpenAPI Setting—SSL	The button must be displayed.
Security Setting/Administrator Password	Set to a password that meets the password rules.
Security Setting—HDD Setting—HDD Lock Password *Otherwise, install the optional security kit, and specify an encryption key.	The hard disk locking password is set.



Detail

If “Account Track” is set to “ON” in the General Settings screen, set “Account Track Input Method” to “Account Name & Password”. If “Password Only” is selected, the setting for “Prohibit Functions When Auth. Error” is not changed, even when “Enhanced Security Mode” is set to “ON”.

[SSL] appears when a certificate is issued from PageScope Web Connection.

Changed settings

For increased security, the following settings are also set when “Enhanced Security Mode” is set to “ON”.

Administrator Setting commands	Changed settings
System Setting—Restrict User Access—Restrict Access to Job Settings—Registering and Changing Address	Set to “Restrict”.
User Authentication/Account Track—General Settings—Public User Access	Set to “Restrict”.
User Authentication/Account Track—User Authentication Setting—Administrative Setting—User Name List	Set to “OFF”.
User Authentication/Account Track—Print Without Authentication	Set to “Restrict”.
Security Setting—User Box Admin. Setting	Set to “Restrict”.
Security Setting—Security Details—Password Rules	Set to “ON”.
Security Setting—Security Details—Prohibit Functions When Auth. Error	Set to “Mode 2” and three times or less for checking.
Security Setting—Security Details—Secure Document Access Method	Set to “Mode 2”.
Security Setting—HDD Setting—Temporary Data Overwrite Setting	Set to “Mode 2”.

**Note**

The number of times for checking for “Prohibit Functions When Auth. Error” can be changed to between 1 and 3.

A changed setting cannot be changed when “Enhanced Security Mode” is set to “OFF”.

When “Password Rules” is set to “ON”, a password that does not meet the password rules is considered a failed attempt during authentication. For details on the password rules, refer to “Password rules” on page 12-105.

For details on the changed network settings, refer to the User’s Guide [Network Scanner Operations].

User operation limitations

When “Enhanced Security Mode” is set to “ON”, an icon appears in the screen and limitations are placed on the user for the following operations.

- A public user cannot use this machine.
- The list of users does not appear in the user authentication screen.
- When user authentication has failed the specified number of times, the control panel can no longer be operated. If operation of the control panel is restricted, touch [Release], and then select the items whose operation restrictions are canceled.
- The recipient cannot be changed by the user.
- This machine’s counter data cannot be retrieved by PageScope Net Care or PageScope VISUALCOUNT-MASTER.
- An application performing the write operation with SNMP v1/v2c cannot be connected.
- Write users using SNMP v3 must be authenticated.

**Note**

For details on the limitations placed on the user for box operations, refer to the User’s Guide [Box Operations].

For details on the limitations placed on the user for printing, refer to the User’s Guide [Print Operations].

For details on canceling operation restrictions applied when authentication failed, refer to “Security setting” on page 12-43.

12.16 Viewing the status of the consumables

This section describes the information that can be viewed after pressing the [Utility/Counter] key, then touching [4 Check Consumable Life].

From the Unit Life Indicator screen, the status (usage level) of the following consumables can be viewed.

- Imaging Unit (C)
- Imaging Unit (M)
- Imaging Unit (Y)
- Imaging Unit (K)
- Fusing Unit
- Transfer Unit

The usage levels are shown in graphs.



Note

The consumables mentioned above are replaceable. For replacements, contact your technical representative.

Displaying the unit life indicator screen

- 1 Press the [Utility/Counter] key.

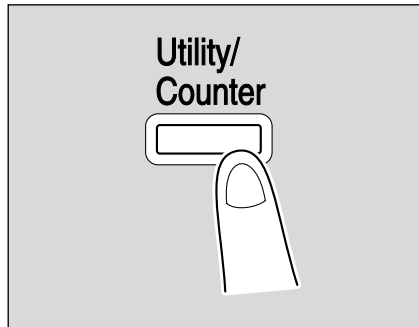

2 Touch [4 Check Consumable Life].

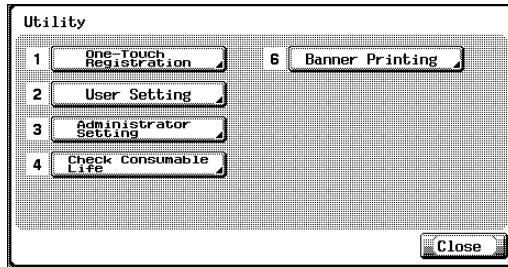

- An item can also be selected by pressing the key in the keypad for the number beside the desired button. For “Check Consumable Life”, press the [4] key in the keypad. The Unit Life Indicator screen appears.

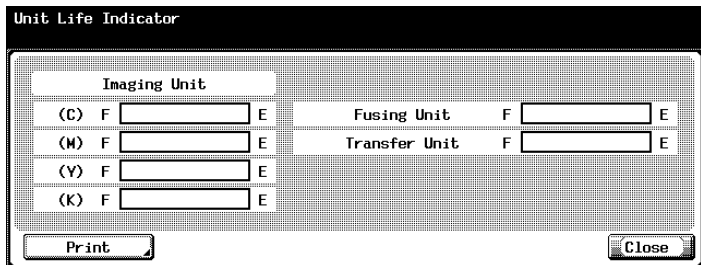

- To print the list of usage levels, touch [Print], and then press the [Start] key.



Note

To quit specifying the Utility mode setting, touch [Exit] in the sub display area or press the [Utility/Counter] key. Otherwise, cancel the Utility mode by touching [Close] in each screen until the screen for the Copy, Fax, Scan or Box mode appears.

13

Appendix

13 Appendix

13.1 Entering text

The following procedure describes how to use the keyboard that appears in the touch panel for typing in the names of registered accounts and custom paper sizes. The keypad can also be used to type in numbers.

Any of the following keyboards may appear.

Example

Password input screen:

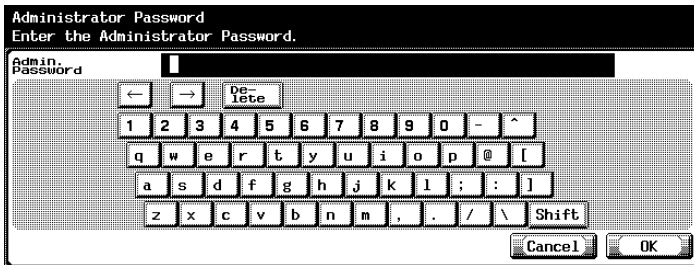

Screen for entering the name of a custom paper size:

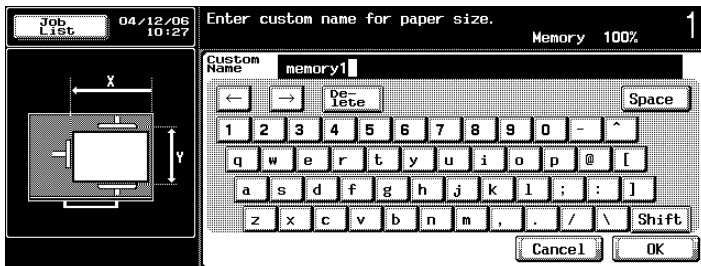

Touching [Shift] switches the keyboard display between lowercase letters (numbers) and uppercase letters (symbols).

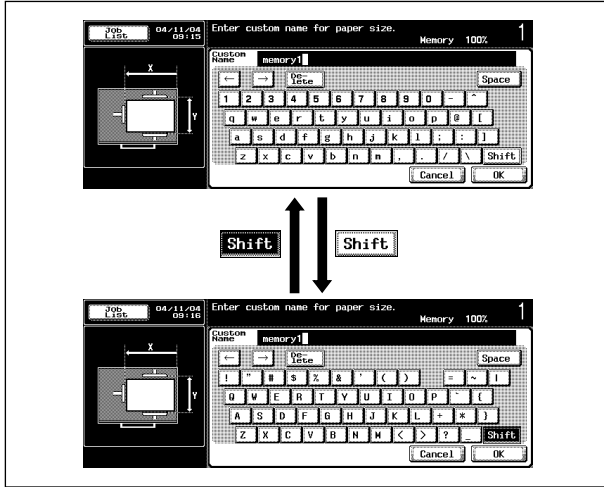

To type text

- Touch the button for the desired character from the keyboard that appeared.
 - To type in uppercase letters or symbols, touch [Shift].
 - Numbers can also be typed in with the keypad.
- The entered characters appear in the text box.

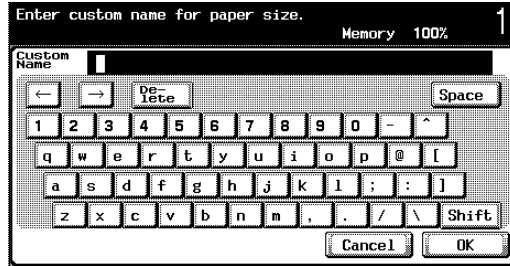
**Note**

To cancel changes to the settings, touch [Cancel].

To clear all entered text, press the [C] (clear) key.

**Detail**

To change a character in the entered text, touch [←] and [→] to move the cursor to the character to be changed, touch [Delete], and then type in the desired letter or number.

List of available characters

Alphanumeric characters/symbols	ABCDEFGHIJKLMNOPQRSTUVWXYZabcdefghijklmnopqrstuvwxyz [space]!"#\$%&'()+,-./:;<=>?@[^_`{ }~*0123456789
---------------------------------	--

13.2 Glossary

The words used in Copy mode are described below.

Abbreviation

ADF

Automatic document feeder; Can be used to automatically scan the document

A

AE Level Adjustment

Set this parameter to adjust the background of the document. The higher the setting, the more that the document background is emphasized. (AE = Auto exposure)

Adjust Color

Set these parameters to adjust the quality of color copies.

APS

“Auto Paper Select” setting

ATS

Automatic paper-tray-switching feature (ATS = Auto Tray Switch)

Auto Zoom

Select this setting to automatically select the appropriate zoom ratio after a document is placed on the original glass or loaded into the ADF and the paper size is selected.

Auto Paper Select

Select this setting to detect the document placed on the original glass or loaded into the ADF, then automatically select paper of the same size if “×1.0” is selected or select the paper size appropriate for the specified zoom ratio.

B

Background Color

Set this function to copy the document using one of the 18 colors available as the color of the background (blank areas).

Background Removal

Select a setting to adjust the density of the background color of the document to one of nine levels.

Blue

Set this parameter to adjust the level of blue in the image, for example, if you wish to emphasize the blue of water or the sky.

Brightness

Set this parameter to make the image either lighter or darker.

C**Change Tray Settings**

Touch this button to specify a paper size not loaded in a paper tray or to copy on paper other than plain paper.

Chapters

Set this function to specify chapter title pages that must be printed on the front side of the paper when printing double-sided copies.

Color Balance

Set this parameter to adjust the balance in the concentrations of cyan (C), magenta (M), yellow (Y) and black (K). Each color can be finely adjusted to any of 19 levels between -3 and +3.

Combine Originals

Select a setting to arrange reduced copies of multiple document pages on a single copy page. The settings for the number of pages that can be combined are "2 in 1", "4 in 1" and "8 in 1".

Contrast

Set this parameter to adjust the contrast between light and dark.

Copy Density

Set this parameter to finely adjust the copy density to any of 19 levels between -3 and +3.

Copy Protection

Set this function to print hidden text in order to prevent improper copying. When a document printed with copy protection text is copied, the hidden text appears clearly repeated in all pages of the copies so that the reader knows that it is a copy.

Cover Mode

Set this function to add paper from the specified paper tray to the copies as a cover page.

D**Density**

Select a setting to adjust the density of the print image to one of nine levels.

Duplex 2nd-Side

Select this setting to switch the image transfer current of this machine when copying on paper that has already been printed on one side.

E**Edit Color**

Set the functions and parameters that are available to adjust the print image as desired

F**Fold & Staple**

Set this function to fold the copies in half and staple them together at the center.

Finishing

Select from the settings that are available for sorting and finishing copies when they are fed into the copy exit tray.

G**Glossy**

Select this setting to print with a glossy finish.

Green

Set this parameter to adjust the level of green in the image, for example, if you wish to emphasize the green of forests and trees.

Group

Select this setting to separate the copies of each page in the document. The specified number of copies of the second page is printed after all copies of the first page are finished.

H**Hue**

Set this parameter to make the image either more reddish or more bluish.

I**Insert Image**

Set this function to later scan multiple images from the original glass and insert them at the desired locations in a document scanned with the ADF, then feed out all copies together.

Insert Sheet

Set this function to insert paper from the specified paper tray into the copies as chapter title pages.

M**Margin**

Select the setting for the position of the binding margin for the loaded document. Selecting the appropriate setting prevents the copy from being printed upside-down when making double-sided copies from single-sided documents or when making single-sided copies from double-sided documents.

Memory Scan

Scans a document exceeding the maximum 100 pages that can be loaded into the ADF by scanning the document in separate batches. The document can be scanned and treated as a single copy job. In addition, the scanning location can be switched between the original glass and the ADF during the scanning operation.

Minimal

Select this setting to produce a copy with the original image slightly reduced.

Mirror Image

Set this function to produce a copy in the mirror image of the original document.

Mixed Original

Select this setting to detect the size of each document page and print a copy on paper of the appropriate size when a document with different page sizes is loaded together into the ADF.

N**Neg-/Pos. Reverse**

Set this function to copy the document with the light- and dark-colored areas or the colors (gradations) of the image inverted.

O**Offset**

Select this setting to separate copies that are fed out.

OHP Interleave

Set this function to insert paper between overhead projector transparencies that are being copied.

This prevents overhead projector transparencies from sticking together.

Original Type

Select the setting for the image type of the document to better adjust the copy quality.

Original Direction

Select the setting for the orientation that the document is placed on the original glass or loaded into the ADF.

P**Paper**

Select settings for the type and size of paper to be printed on.

Proof Copy

Press this key to print a single sample copy and stop the machine so that it can be checked before printing a large number of copies. This prevents copy errors from occurring in a large number of copies.

Punch

Select the setting to punch holes in the copies for filing.

R**Red**

Set this parameter to adjust the level of red in the image, for example, if you wish to redden skin tones.

S**Saturation**

Set this parameter to adjust the degree of vividness of the colors in the image.

Save in User Box

Temporarily saves the job on the hard disk so that it can later be recalled and used again

Sharpness

Set this parameter to emphasize the edges of text so that they can be read more easily. In addition, this parameter can be used to adjust the document image.

Sheet/Cover/Chapter Insert

Select from the functions that are available to edit copies as desired

Simplex/Duplex

Select the setting to specify if the scanned document and the printed copy are printed on just one side or both sides.

Sort

Select this setting to separate each set of the copies. The second copy set is printed after all of the first copy set is finished.

Staple

Select a setting to staple copies together.

T**Text Enhancement**

Select a setting for the reproduction quality of text when copying documents consisting of text that overlaps images such as illustrations or graphs (text with a background).

Thick Original

Select this setting when loading thick documents or document pages pasted together into the ADF. If this setting is selected when thick documents are scanned with the ADF, there is a smaller chance of a paper misfeed occurring.

X**XY Zoom**

Touch this button to use the keypad to specify the zoom ratio for producing an enlarged/reduced copy of the loaded document.

Z**Zoom**

Specify the zoom ratio of the copy.

13.3 Index

Numerics

- 1-sided/2-sided print 3-49
- 1st tray 2-5, 2-47, 5-11
- 2nd tray 2-5, 2-53, 5-12
- 3rd tray 2-5, 2-53, 5-13
- 4th tray 2-5, 2-53, 5-13

A

- Accessibility mode 4-23
- Account track 2-43, 12-38
- Accounts 12-78
- Active jobs 11-11
- ADF 2-2, 3-7, 5-28, 6-5, 7-25
- Adjust color parameters x-28, 8-53
- Administrator settings
..... 2-43, 12-27, 12-37, 12-47
- Authentication method 12-78
- Auto paper select 3-35, 7-9
- Auto zoom setting 3-38
- Automatic duplex unit 2-5, 5-10, 6-5
- Automatic panel reset 2-34
- Automatic paper tray switching 7-8
- Automatic system reset 2-34

B

- Background color x-45, 8-51
- Background removal 3-59, 3-61
- Basic screen 2-24
- Binding 3-80
- Blue parameter x-34, 8-53
- Book copy 8-24
- Booklet 8-43
- Booklet original 8-29
- Brightness x-30, x-37, 8-53
- Bypass tray 2-5, 2-58, 5-9

C

- Capacities 7-4
- Caution notations and labels 1-16
- Center binding 3-80
- Center erase 3-82, 3-83, 8-25
- Chapters 8-16
- Checking jobs 11-2
- Cleaning 10-2
- Clearing a paper misfeed in a
paper/media tray 5-11
- Clearing a paper misfeed in
finisher FS-501 5-40
- Clearing a paper misfeed in
finisher FS-603 5-45
- Clearing a paper misfeed in the
ADF 5-28
- Clearing a paper misfeed in the
automatic duplex unit 5-10
- Clearing a paper misfeed in the
bypass tray 5-9
- Clearing a paper misfeed in the
fusing unit 5-19
- Clearing a paper misfeed in the
LCT 5-14
- Clearing a paper misfeed in the
right-side door 5-16
- Clearing a staple jam 9-24
- Clearing a staple jam in finisher
FS-501 9-35
- Clearing a staple jam in finisher
FS-603 9-37
- Color balance x-35, 8-53
- Color gradations 12-75
- Color parameters x-28, 8-53
- Color settings x-43, x-44, 3-32
- Combine originals settings 3-64
- Consumable status 12-110
- Contrast x-38, 8-53

Control panel	2-21
Control panel angle	2-27
Control panel settings	4-23
Copier setting	12-22, 12-40
Copy density	x-42, 8-53
Copy paper	7-2
Copy programs	4-10, 4-14
Copy settings	4-2
Copy type settings	3-49
Counters	10-8
Cover mode	8-5
Cover pages	8-5
Current jobs	11-11
Custom paper size setting	7-13

D

Date/time stamp	8-67
Default settings	12-21
Deleting a printing/reserved job	11-6
Deleting a stopped/reserved job	3-87
Density settings	3-59, 3-60
Destination register	12-14, 12-37
Display setting	12-19
Distribution numbers	8-67, 8-75
Document selection	3-49
Double-sided copies	3-53

E

Emptying the waste container	9-43
Enlarge display timer setting	4-26
Enlarging	3-41
Entering text	13-2
Erasing center	3-82, 3-83, 8-25
Erasing frame/borders	8-61
Error message	5-2, 5-5, 5-49, 5-50, 5-52, 5-53, 10-10
Error messages	5-59

F

Fax setting	12-41
Features	x-18
Feeding documents	3-7
Finisher FS-501	2-18, 5-40, 6-12, 9-35
Finisher FS-514	2-14, 6-8
Finisher FS-603	2-16, 5-45, 6-11, 9-37
Finishing settings	3-67
Folding position adjustment	12-58, 12-69
Fusing unit	5-19

G

Glossary	13-5
Gradation levels	12-75
Green parameter	x-33, 8-53
Group setting	3-71

H

Held jobs	11-11
Help menu	4-17, 4-20
Help screens	4-17, 4-22
Hole-punch waste	9-43
Hole-punching	3-77
Hue	x-30, x-41, 8-53

I

Image centering/rotation	8-63
Image repeat	8-33
Initial setting	12-21
Insert image	8-12
Insert sheet	8-8
Interrupting a copy job	4-8

J

Job details	11-10
Job history	11-12

Job list	11-2
Job separator JS-601	2-18, 6-13
Job settings	11-8

K

Key repeat start/interval time	4-23
--------------------------------------	------

L

LCT	2-2, 2-5, 2-55, 5-14
Leading edge adjustment	12-50
Left edge adjustment	12-52
Legal restrictions on copying	x-54
Loading paper/media	2-47, 2-53, 2-55, 2-58
Low power mode	2-35, 2-37

M

Machine setting	12-37
Mailbin kit MT-501	2-13, 6-10
Main unit	2-2, 6-2
Malfunction detected	5-2
Managing jobs	11-2
Margin setting	3-26, 8-58
Memory full	5-50
Message display time	4-28
Messages	5-59
Meter count	10-8
Mirror image	x-47, 8-47
Misfeed	5-5, 5-9, 5-10, 5-11, 5-13, 5-14, 5-16, 5-19, 5-28, 5-40, 5-45
Misfeed detected	5-5
Mixed original setting	3-20
Mode check	4-2
Mode memory	4-10, 4-14
Multi-page document scanning	3-15

N

Negative/positive reverse	x-46, 8-45
---------------------------------	------------

Network setting	12-40
Next job reservation	3-84
Numbering	8-71, 8-75

O

OHP interleave	8-2
Operating environment	1-18
Original direction setting	3-24
Original glass	3-9, 7-28
Original image type settings	3-55
Original settings	3-20
Output tray OT-601	2-14, 6-9
Oversized paper setting	7-18

P

Page numbering	8-67, 8-71
Panel reset	2-34
Paper capacities	7-4
Paper feed cabinet PC-103	6-7
Paper feed cabinet PC-203	6-7
Paper feed cabinet PC-403	6-7
Paper misfeed	5-5, 5-9, 5-10, 5-11, 5-13, 5-14, 5-16, 5-19, 5-28, 5-40, 5-45
Paper misfeed location	5-7
Paper settings	3-35, 7-9
Paper size setting	3-37, 7-11
Paper sizes	7-2
Paper storage	7-7
Paper/media types and capacities	7-4
Part names/functions	2-2
Password rules	12-105
Poster mode	8-38
Power source	1-18
Preset zoom ratios	3-41
Preventive maintenance time	10-10
Printer setting	12-24, 12-41
Printing priority	11-17

- Program job 8-19
- Proof copy 4-5
- Punch kit PK-501 2-16, 6-12
- Punch kit PK-510 2-14, 6-9
- Punch settings 3-77
- Punching horizontal position
adjustment 12-62
- Punching resist loop size
adjustment 12-64
- ## R
- Red parameter x-32, 8-53
- Reducing 3-41
- Regulation notices 1-9
- Replacing a staple cartridge for
finisher FS-501 9-16
- Replacing a toner cartridge 9-2
- Replacing parts/supplies 5-52, 5-53
- Replacing the staple cartridge 9-10
- Replacing the staple cartridge for
finisher FS-603 9-19
- Replacing the waste toner box 9-50
- Replenish paper 5-49
- Reserving a copy job 3-84
- ## S
- Saddle stitcher SD-503 2-13, 6-9
- Safety information 1-2
- Sample copy 4-5
- Saturation x-30, x-39, 8-53
- Scanner setting 12-24
- Scanning 2-31, 3-11, 3-15
- Security setting 12-43
- Separate scan setting 3-11
- Set numbering 8-67, 8-75
- Set zoom ratios 3-46
- Sharpness x-40, 8-53
- Simplex/duplex settings 3-49
- Single-sided copies 3-51
- Sleep mode 2-36, 2-37
- Sort setting 3-70
- Sound setting 4-30
- Space requirements 1-17
- Special paper/media 7-5
- Special paper/media setting 7-21
- Specifications 6-2
- Staple cartridge 9-10, 9-16, 9-19
- Staple jam 9-24, 9-35, 9-37
- Stapling 3-72
- Stapling position adjustment
..... 12-60, 12-66
- Starting print position 12-50, 12-52
- Stopping printing/scanning 3-86
- Stored jobs 11-13, 11-15
- System connection 12-42
- System reset 2-34
- System setting 12-17, 12-27
- ## T
- Test print 4-5
- Text enhancement 3-59, 3-63
- Text entry 13-2
- Text quality adjustment 3-63
- Thick original setting 3-22
- Toner cartridge 9-2
- Touch panel adjustment 4-33
- Troubleshooting 5-2
- Troubleshooting reference tables
..... 5-55
- Turning off 2-33
- Turning on 2-29
- ## U
- Unit life indicator 12-110
- User authentication
..... 2-40, 12-38, 12-78
- User's guide conventions x-48
- User's guides x-52

Utility mode parameters	12-2
Utility setting	12-25
Utility settings	12-17

W

Waste container	9-43
Waste toner box	9-48
Weekly timer	2-38, 12-49
Wide paper setting	7-18

Z

Zoom minimal setting	3-40
Zoom ratio setting	3-42, 3-47
Zoom settings	3-38

● This manual was printed using 100% post-consumer recycled paper.

● This manual was printed with soy ink.



KONICA MINOLTA

<http://konicaminolta.com>