

# bizhub PRO 920

## Specifications

Model name		bizhub PRO 920	
Type	Console with document feeder (B/W Copier / Printer / Scanner)		
Resolution	Scanning	600 x 600dpi	
	Printing	600 x 600dpi	
Memory	DIMM	256MB DIMM (standard)	
	HDD	40GB (standard)	
Paper sizes	100 x 148mm - 314 x 460mm / 3-3/4 x 5-3/4in - 12-1/4 x 18in		
Warm-up Time	Less than 5.5 minutes		
First-copy Time	3.1 seconds (A4, tray 1, platen 1:1, non AE, face-up)		
Copy Speed	92cpm		
Magnification	Fixed	Fixed Ratio: 1:1; Reduction: 0.500/0.707/0.816/0.866 Enlargement: 1.154/1.224/1.414/2.000	
	Zoom	Zoom: 25% to 400% in 0.1% increments, 3 user settings, bi-directional zoom	
Paper capacity	2 x 500 + 1,000 sheets; 150 sheet multi-bypass		
Paper weights	60-200g/m <sup>2</sup> (tray 1 / 2 / 3), 50-200g/m <sup>2</sup> (multi-bypass, LU-403 / 404)		
Multiple copy	Up to 9,999		
Power requirement	230V/15A		
Power consumption	Less than 3.45kW		
Dimensions (W x D x H)	887 x 780 x 1,203mm / 35 x 30-3/4 x 47-1/2in (with DF)		
Weight	Approx. 280kg / 617-1/4lb (main unit + DF)		

## System Options

LU-403	Large Capacity Unit for 4,500 sheets (A4, max. 314 x 223mm), 50-200g/m <sup>2</sup>
LU-404	Large Capacity Unit for 4,000 sheets (up to A3, max. 314 x 460mm), 50-200g/m <sup>2</sup>
FS-509 Staple Finisher	3 stapling positions Non-sort mode capacity: 3,000 sheets Max. stapling capacity: 100 sheets (80g/m <sup>2</sup> )
FS-604 Booklet Finisher	Center-fold & three-fold capabilities Non-sort mode capacity: 2,500 sheets Max. stapling capacity: 50 sheets (80g/m <sup>2</sup> ), 20 sheets for saddle stitching
PI-501 Post Inserter	Capacity: 200 sheets Paper weight: 50-200g/m <sup>2</sup> (regular & special paper)
TU-501 Trimming Unit	Capacity: 500 sheets Max. trimming capacity: 40 sheets (80g/m <sup>2</sup> ) *MK-707 Mount Kit required
PK-505 Punch Kit	2- or 4-hole selectable, Paper size: A5-A3 Paper weight: 50-128g/m <sup>2</sup>
ZU-602 Z-folding Unit with Punching Unit	2- or 4-hole selectable Paper size: A5-A3

## Print Controller (optional)

Model		IC-203	
Type	Embedded Type		
CPU	Low Voltage Pentium® III Tualatin 800MHz		
Memory	Standard	256MB	
	Maximum	512MB	
Speed	92ppm		
Resolution	600 x 600dpi, 2,400 x 600dpi emulation		
Printer Languages	Standard	PCL 5e / 6 / TIFF Direct Print	
	Option	PostScript3 / PDF Direct Print	
Network Protocol	TCP/IP, IPX/SPX, NetBEUI, IPP, EtherTalk		
Operating System	Windows98/Me, WindowsNT / 2000 / XP / Windows Server 2003 Mac OS 9.0 or later, Mac OS X (10.2 / 10.3)		
Fonts	Standard	European Font 80 types (Agfa Micro type, Symbolset 36 kinds)	
	Option	European Font Adobe 136 types	
Interface	Ethernet (100BASE-TX / 10BASE-T), IEEE1284		

## Scanner (requires IC-203)

Type	B/W
Speed	92opm
Max.Original size	A3 (297 x 420mm)
Scanner File Format	TIFF, PDF (ver. 1.3)
Scanner Resolution	200 x 200dpi / 300 x 300dpi / 400 x 400dpi / 600 x 600dpi
Interface	Ethernet (100BASE-TX / 10BASE-T)

## Converting paper weight

Multiply g/m<sup>2</sup> weight x 0.636 x 0.939  
1kg = Approx. 1.66g/m<sup>2</sup>

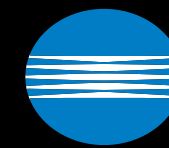

KONICA MINOLTA

# bizhub PRO 920

The 92ppm/cpm  
On-demand Solution for Heavy Volume Printing



## Product appearance, configuration and / or specifications are subject to change without notice.

- bizhub is a registered trademark of KONICA MINOLTA BUSINESS TECHNOLOGIES, INC.
- Windows is a registered trademark of Microsoft Corporation.
- Adobe and PostScript are registered trademarks of Adobe Systems, Inc.
- All other brand and product names are registered trademarks or trademarks of their respective companies.
- As an ENERGY STAR Partner, KONICA MINOLTA BUSINESS TECHNOLOGIES, INC. has determined that this product meets the ENERGY STAR guidelines for energy efficiency.
- ENERGY STAR is a registered trademark in the U.S.

## KONICA MINOLTA copiers and multi-functional products are designed with the environment in mind.

- Meet ENERGY STAR Guidelines
- Use Recycled Materials
- Toner Recycle Mechanism
- Production at ISO-Certified Factories



## Requirements for safe use.

- Please read and follow the instruction manual to ensure safe operation.
- Only operate using appropriate power supply and voltage.
- Connecting the earth wire to an inappropriate place may cause explosion or electric shock.  
Please connect accordingly (Taiwan and the Philippines only).

KONICA MINOLTA  
BUSINESS TECHNOLOGIES, INC.

1-6-1 Marunouchi Chiyoda-ku, Tokyo, Japan  
<http://www.biz.konicaminolta.com>



This catalog was printed on recycled paper with soy ink.



9251-3146-31 Printed in Japan

The essentials of imaging

## Develop Your On-demand Printing Capabilities

On-demand printing is a fast-growing part of production printing. Whether for customers or in-house, you require customization of output at every stage of the process, with the quality, speed and reliability your business demands. Every job has unique needs, and your traditional printing infrastructure is now being called upon to handle work it wasn't designed for. The solution: the bizhub PRO 920, a versatile new on-demand printing system that gives your business the flexibility to satisfy a growing variety of printing needs and develop new business opportunities.



## bizhub PRO

The bizhub PRO brand is Konica Minolta's new approach to meeting the industry needs of Print Professionals. Every product in the bizhub PRO lineup is designed to expand the range of services offered by production print businesses. From in-house print offices hoping to improve efficiency, to pay-for-print shops looking for a reliable high-speed machine with advanced features, to commercial printers who want to expand their small-lot, on-demand capabilities. bizhub PRO is more than printers, it's a means for you to open up new business opportunities.

# bizhub PRO 920

- 92ppm/opm
- 6,650-sheet capacity
- 2,400 x 600dpi printing
- Folding, binding, trimming capability
- Advanced paper size/weight handling
- Flexible networking
- Advanced security features
- Tandem Copying and Printing



## Fast, Flexible, Efficient

On-demand printing requires you to be ready as soon as a job comes in. Time spent getting ready or waiting for other jobs to finish is time lost for you and your customers. With the bizhub PRO 920, however, your business can run at peak efficiency.

High-speed, high-quality output



### Excellent Printing Speed

The bizhub PRO 920 offers a 92ppm (A4) output speed from either print data or scanned originals.

### 99-job Memory

The bizhub PRO 920 has 256MB of RAM plus 10GB of the 40GB internal HDD available to store waiting print jobs, allowing up to 99 jobs to be queued. This reduces waiting times and enables the bizhub PRO 920 to keep up with your office even during the busiest work periods.

### First Copy in 3.1 seconds

With an initial warm-up time of 5.5 minutes and a first copy output time of just 3.1 seconds, walk-in print jobs can be started almost immediately.

### High Output Resolution

For scanned data, bizhub PRO 920 delivers a 600 x 600dpi output resolution that stays faithful to the original data. For printed data, additional digital enhancements raise the effective resolution to 2,400 x 600dpi for beautiful reproductions of photos and finely detailed gradations.

### 6,650-sheet Tray Capacity

With one 1,000-sheet tray, two 500-sheet trays and a 150-sheet multi-bypass tray, the bizhub PRO 920 main unit can hold over

2,000 sheets. The addition of optional large-capacity units, available in A4 or A3 sizes, boosts this figure all the way to 6,650 and 6,150 sheets respectively, letting you easily handle even large on-demand jobs.

### Tandem Copying and Printing for Larger Jobs

A function for tandem connectivity allows connection of two bizhub 920 units. This doubles output capabilities to 184ppm (A4) for high-speed handling of large-scale on-demand print jobs.

6,650-sheet maximum capacity



### Networking Convenience

The internal IC-203 Print Controller (optional) enables you to connect the bizhub PRO 920 directly to your office network for easy data delivery, layout preparation, output preview and job management. The IC-203 is compatible with Windows and Macintosh environments, and supports major network protocols, including TCP/IP, IPX/SPX, NetBEUI, IPP and EtherTalk.

### File Merging

Any number of files stored on the main unit's HDD can be reprinted together as a single job while keeping all the separate print settings for each individual file. Because you do not have to re-RIP the data, printing is much faster. Users may also change finishing settings to output files as a single document.

### Image Merging

Images from separate files stored on the main unit HDD may be brought together and output as a single job. Users may customize output settings to add stapling, single or double-sided printing, etc.

### First to Last Printing

For scanning and output, you can select I-to-N (first to last) or N-to-I (last to first) printing. You can also choose between face-up and face-down output, eliminating the need for manual collation after printing.

### Mixplex Printing

Separate print settings for each type of sheet insertion allow you to create documents consisting of single and double-sided pages. Settings are available for front and back covers, section breaks and interior pages.

### Other Copy & Print Functions

- Auto zoom
- Auto paper select
- Vertical / horizontal zoom
- Insert sheet
- Mixed size original copying
- Z-fold original mode
- Irregular-size / index-size sheets
- Chapter mode
- OHP interleave mode
- Program job
- Book copy
- Image repeat mode
- Booklet mode
- Negative / positive reverse
- Image overlay
- Page margin shift mode
- Reduce & shift
- Frame / center erase
- Non-image area erase
- Image centering
- Full scan
- Image rotation
- Density shift
- Perfect binding preparation
- Annotation Function

Flexible input / output capabilities

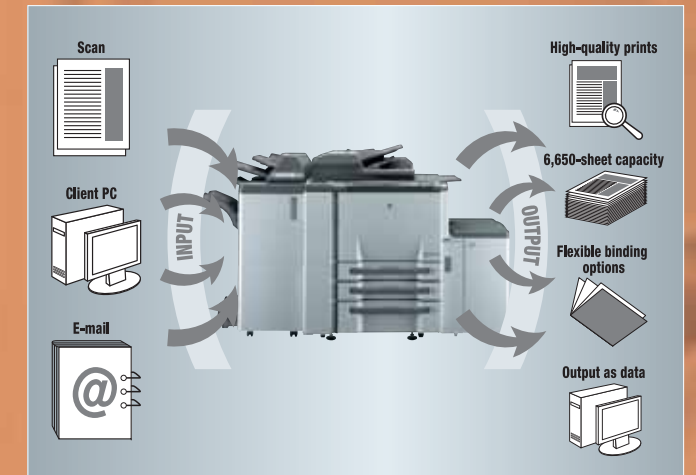

### N-in-One Printing

1	2	3	4
5	6	7	8

From scanned data, up to 8 pages can be printed on a single sheet of paper. For print data, select from 2-in-1, 4-in-1, 6-in-1, 8-in-1, 9-in-1 or 16-in-1 to reduce paper consumption or for facilitating the viewing of related pages together.

### Stamp & Watermark



Important information to help keep track of documents can be added automatically when you print. Add output date, page number, document number or choose from a variety of watermarks to indicate confidentiality or document type in 9 possible locations. The stamp function will support future features like document annotation, allowing users to input original text for stamping documents.

### Image Repeat



A single image or block of text, either from scan data or print data, can be printed multiple times on a single sheet of paper. This can be used for easy production of seals and labels.

### Annotation Function

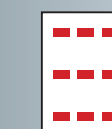

This function allows you to stamp output of scanned documents with important information to facilitate effective management. Original text, the date and time the document was scanned and a counter number that can be set to increase for each new scanned document or job can all be stamped in your choice of 9 locations.



## Advanced Finishing

On-demand jobs may be smaller than most commercial print jobs, but that doesn't make the customer requirements any less complex. Fortunately, the bizhub PRO 920 is ready with a full array of standard finishing capabilities and optional modular components.

Main unit with FS-604 Saddle Stitch Finisher, PI-501 Post Inserter, TU-501 Trimmer Unit (with MK-707 Mount Kit) and LU-404 Large Capacity Unit



### Advanced Page Layout Options

The bizhub PRO 920 can adjust page order and document layout in preparation for folding, saddle stitching or other finishing processes, whether one-sided, double-sided or mixed. Now arranging documents into folded pamphlets, multi-page booklets or more advanced layouts is quick and convenient.

### Per-page Setting

The bizhub PRO 920 gives users a great deal of flexibility in arranging multi-page documents. Pages within a document can be selected for stapling, and users can also switch between single-sided and double-sided printing.

### Proof Print

The proof print function is especially useful when preparing large jobs with complex finishing instructions. By running off a single print, users can prevent time and resource-wasting mistakes by confirming that all layout and binding settings are correct.

### Flexible Paper Compatibility

The bizhub PRO 920 can handle paper sizes ranging from post-card size (100 x 148mm) to A3 wide (314 x 460mm) and weights from 50 to 200g/m<sup>2</sup>. Users can also mix paper sizes and weights when printing.

### Multi-tray Paper Feed

During printing, paper supply can be switched between trays. Empty trays can be opened and refilled during printing, allowing large jobs to be completed with minimal interruptions.

### Up to 6,650-sheet Paper Supply

Two optional Large Capacity Units give users an additional paper capacity of 4,500 A4 80g/m<sup>2</sup> sheets (LU-403) or 4,000 A3 80g/m<sup>2</sup> sheets (LU-404).

### Post Inserter

The optional PI-501 Post Inserter, which connects to either of the optional finishers (FS-604 or FS-509), expands post-print capabilities by letting you add heavy stock or pre-printed color covers. The two separate input trays give you the ability to include cover sheets and chapter break sheets simultaneously.

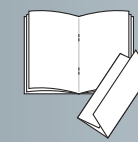

### Fold and Bind

With the optional FS-604 Saddle Stitch Finisher or FS-509 Staple Finisher, users can choose from 1-point corner stapling or 2-point side stapling. The FS-604 unit also allows center-stapled saddle stitching of up to 20 sheets. The FS-604 is especially useful for producing brochures and direct mailings, giving the additional folding options of 2-fold booklet-style and (with A4 paper) 3-fold internal-fold or external-fold styles.

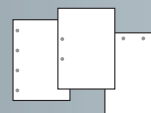

### Automatic Hole Punching

The optional PK-505 Punch Kit is available with both the FS-604 and FS-509 finishers. It is capable of 4-hole or 2-hole side punching, and 2-hole top-punching.

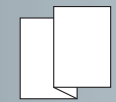

### Z-folding

The optional ZU-602 Z-folder is capable of folding A3-size paper in Z-fold style, to fit inside A4-size booklets. Includes built-in hole punching unit.

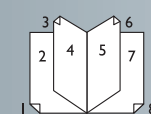

### Perfect Binding Preparation

The bizhub PRO 920 automatically repaginates and prints data in preparation for perfect binding. With either of the optional finishers (FS-604 or FS-509) you can also fold pages, further reducing the manual labor required.



### High-quality Booklet Trimming

When creating multi-page centerfold documents, the center pages inevitably stick out. The optional TU-501 Trimmer Unit cuts the edges flush to let you produce high quality, professional-looking booklets.



Staple Finisher with Z-folder and Punching Unit



Saddle Stitch Finisher with Punch Kit



Trimmer Unit with Mount Kit



Large Capacity Unit (A3)



Large Capacity Unit (A4)



Post Inserter with manual control panel





## Connect with Your Customers

The bizhub PRO 920 is more than just a stand-alone printer/copier. Its advanced networking capabilities let you prepare, access and manage print jobs from any connected PC, as well as receive job data via e-mail or save scan data in a variety of formats, all in a secure network environment. This gives your business the opportunity to add new degrees of flexibility in how it handles on-demand printing.

### Security

Keeping your customers' data, as well as your own, secure from unauthorized access is a must in any business. The many security features, including user authentication, on the bizhub PRO 920 create a safe working environment.

- User privilege settings: with User Authentication, network administrators can assign access privileges to any staff on the system, so data is only accessible by authorized users.
- HDD data protection: when operating in Enhanced Security mode, scan and print data stored on the bizhub PRO 920's internal hard drive require a password for access.
- Full memory erase: data stored in the hard drive and active memory can be completely erased after printing or scanning.
- Security Log: all activity data, including job descriptions, user ID, time of access, etc., is logged in a history file. With this information, unauthorized access can be easily detected by administrators.
- ISO 15408 certification: the bizhub PRO 920 has been certified compliant with ISO 15408 (EAL Level 3) security standards.  
\*The ISO 15408 certification applies only to IT security capabilities. This certification is NOT a product guarantee.



### Network Scanning

The bizhub PRO 920's optional IC-203 Print Controller and Scan to HDD functions give you the ability to send scan data to any PC on your network, as well as to outside recipients via a number of different methods.

- Scan to E-mail: save data as an e-mail attachment (PDF or TIFF formats) and send to any address
- Scan to FTP: forward large data to an FTP server for archiving in a designated directory. Information is available for immediate download from any client PC, enabling a high level of data sharing and management
- Scan to SMB: send data directly to a sharing folder on any client PC for editing and re-use in a serverless environment
- Scan to HDD: save data to the print controller's HDD and retrieve from a connected PC using a TWAIN driver. Or install PageScope Scan Direct and easily scan data directly to your PC
- Scan to Multi-send: scan data only once and simultaneously send to FTP, SMB, HDD or an e-mail address, or any combination of these all at once
- LDAP Compatibility: using LDAP, (Lightweight Directory Access Protocol), the e-mail address manager can access directories to compile useful lists of recipients. This list can be used with the Scan to e-mail function to send data to a large group of recipients.

### Box Functions & Internal File Storage

30GB of the bizhub PRO 920's 40GB internal hard drive is available to users for storing print, copy or scan data for re-use without having to re-RIP. For convenience and security, the hard drive can be partitioned into folders, with access to each folder limited to individual users, work groups or anyone in your company. This flexible data sharing ensures that important job data is available to those who need it, whenever they need it.

### Versatile Data Handling

PageScope Workware is available as a payware option for installation on your PC. This document management application provides a powerful set of tools for handling scanned data. All scanned data is converted to PDF format, which users can then copy, move, merge or delete.

### Web Server Utilities

The IC-203 Print Controller comes pre-installed with PageScope Web Connection, enabling acquisition of machine settings and status.

Internal file storage and organization

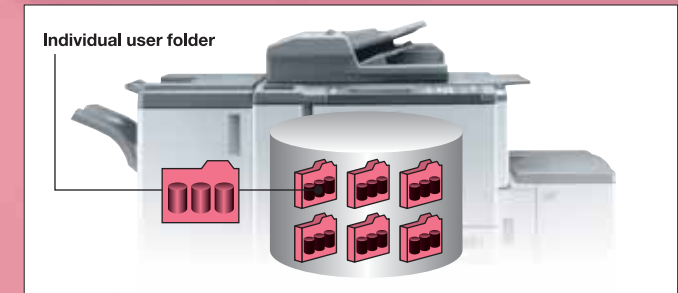

PageScope Web Connection

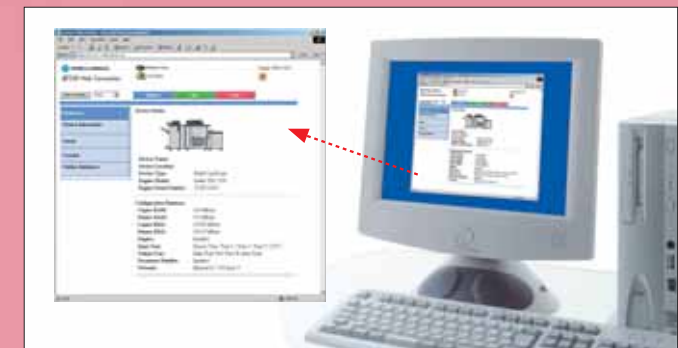

PageScope Direct Print and PageScope Job Spooler

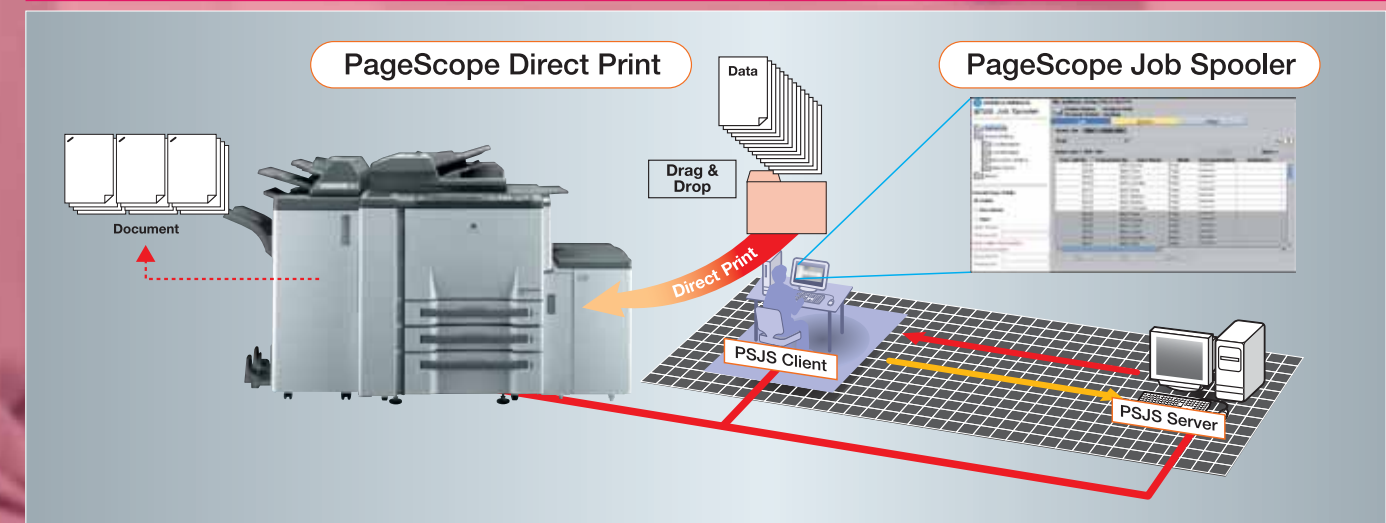

### Direct Print

Using the supplied PageScope Direct Print software, you can print PDF or TIFF files simply by dragging them onto the Direct Print icon and choosing how many sets you want. Because you don't need to open the native application, the file or the printer driver, you can cut down printing time considerably.

### Advanced Job Management Capabilities

With PageScope Job Spooler, your network manager can assign priority levels to individual jobs, set user privileges and keep records of all print job activity. Queue order for spooled and scanned jobs can be rearranged at the control panel or from a connected PC. Aborted jobs can also be easily deleted.

Scanner functions

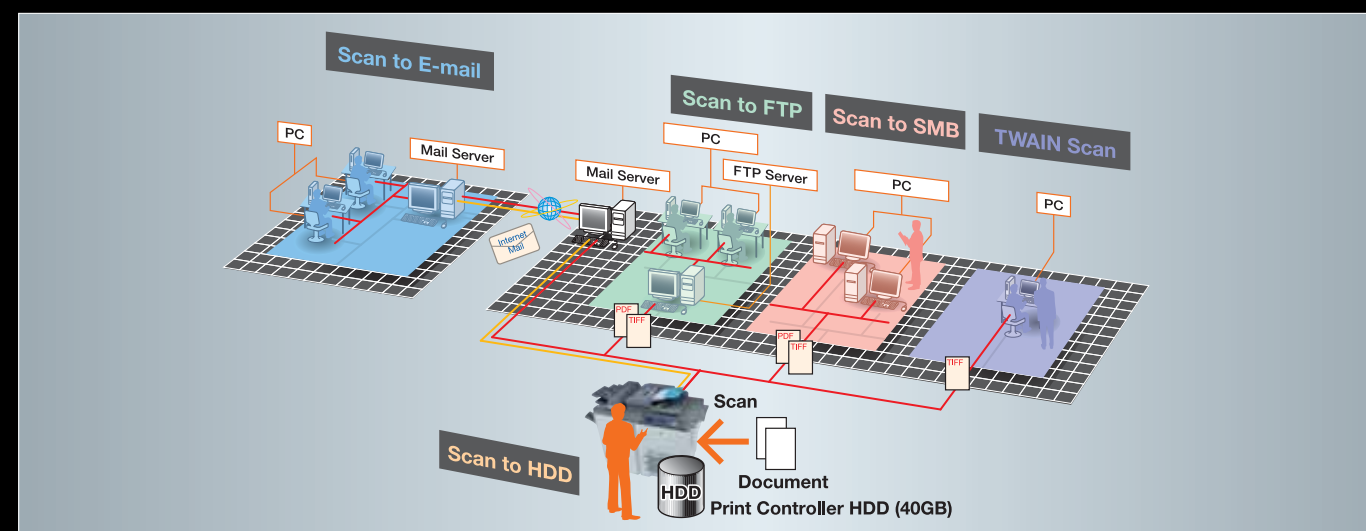



## High Quality Printing

Speed is only part of the equation, which is why every bizhub PRO machine is designed to deliver amazing print quality every time. The advanced paper handling technology, meanwhile, ensures a smooth output flow, even on big or complex jobs.

### Advanced Toner for Better Print Quality

The bizhub PRO 920 offers reproduction of sharp images, illustrations and gradations that will satisfy even the exacting demands of your customers. Konica Minolta's newly developed Simitri polymerized toner is composed of small, uniformly shaped particles, that produce deeper blacks and sharper lines that resist fading over time. The result is improved reproduction of fine characters and halftone images. The bizhub PRO 920's Simitri toner also features a lower fixing temperature, which reduces the amount of paper curl caused by the heat.

### Automatic Exposure Selection

When scanning text printed on colored paper, the bizhub PRO 920 can adjust contrast, exposure and toner density balance to reduce background color and ensure that the text stands out clearly.

Polymerized Toner

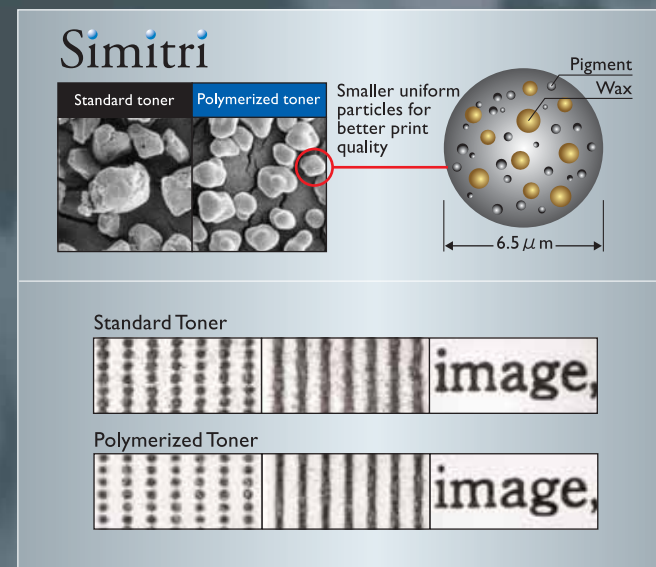

High-capacity toner bottle



### High-capacity Toner Bottle

The large toner bottle and hopper provide enough toner for about 66,000\* A4 prints. And because new toner and recycled toner are mixed together inside the hopper, uniformity is maintained even when the toner bottle is replaced mid-job.

\*Based on Konica Minolta testing. Actual figures may vary depending on usage.

Offset-quality overprinting

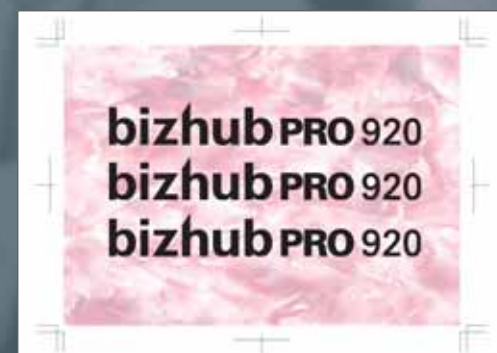

### Higher Overprint Quality

The bizhub PRO 920 has the ability to print on previously offset-printed documents. The Simitri polymerized toner creates a smooth surface, with almost no difference from the offset ink. This enables variable printing of high-quality documents.

## Complete Access

The bizhub PRO 920 features an advanced, user-friendly design that maximizes accessibility and gives users an intuitive printing environment to work in.

### Intuitive Control Panel

The control panel features a large 640 x 240 pixel LCD that displays operations in a clear, easy-to-use format. High-contrast buttons make entering instructions convenient, and a flashing LED indicates when print data is being received.

### Intelligent Design

The paper size and alignment indicators on the platen and ADF feed tray use high-contrast markings for clear visibility, while the ADF has right-hand and left-hand grips for easy opening. The output trays also use high-contrast coloring to help prevent documents from being left behind.

### Thumbnail Display of Box Data on the LCD

A thumbnail image of data stored in the box can be displayed on the control panel, making it convenient to identify the files you want to output.

### Easy-grip Paper Trays

All trays feature a universally designed grip, making them easy to hold with either an ordinary or underhand grip. Their shape and size also make them easy to pull out.

### Remote Panel for Universal Access

The bizhub PRO 920's control panel interface can be installed on your PC to provide seamless access to all functions available at the console.

Large LCD panel



Remote panel



Easy-grip paper trays



Smart ADF design



Easy-access output tray



## Being Green

At Konica Minolta, we take the protection of the environment seriously. That's why the complete life cycle of every bizhub PRO has been continually revised and reexamined in an effort to minimize waste and potentially harmful substances. The result is a machine that, while sacrificing none of the quality you demand, leaves behind as small an impression as possible on the environment.

### RoHS Compliance

Ahead of the EU's deadline for compliance with RoHS (Restriction of Hazardous Substances) regulations, Konica Minolta will eliminate the use of harmful materials, including lead, mercury, cadmium, hexavalent chromium, PBB and PBDE from the production of all electrical and electronic components.

### WEEE Compliance

Konica Minolta is committed to achieving full compliance with WEEE (Waste Electrical and Electronic Equipment) regulations for the bizhub PRO 920. As such, Konica Minolta will guarantee proper recycling and disposal of all components and parts.

### Energy Star

The bizhub PRO 920 conforms to the guidelines of the International Energy Star Program for reduced energy consumption and improved efficiency.



### Toner Polymerization

Compared to the pulverization method of toner production used previously, polymerized toner production is much kinder to the environment, consuming less energy and producing up to 40% less carbon dioxide, NO<sub>x</sub> and SO<sub>x</sub> as wastes.

### Low-temperature Toner Fixing

The polymerized toner used in the bizhub PRO 920 fixes at a significantly lower temperature than previous toners. This results in less energy being required for normal operation, but without losing print quality.

### Toner Recycling

The bizhub PRO 920 maximizes toner recovery and re-usage for more efficient toner consumption with as little waste as possible.